



Rosenberger provides a variety of coaxial inserts, high voltage and high power inserts. Due to their small dimensions, high packing densities are possible.

A part of these products are designed as reverse polarity versions.

*Für Anwendungen in Mischleisten bietet Rosenberger eine Vielzahl an Koaxial-Einsätzen, Hochstrom- und Hochspannungs-Einsätzen, die aufgrund ihrer geringen Abmessungen hohe Packungsdichten erlauben. Ein Teil der Produkte wird als Reverse Polarity-Ausführung angeboten.*



# Inserts: Mini-Coax, D-Sub, 1.0-2.3, 08.-2.7 DIN 41626, High Voltage & Power

## Contents

Mini-Coax

D-Sub

1.0-2.3 DIN 41626 (50  $\Omega$ , 75  $\Omega$ )

0.8-2.7 75  $\Omega$

High Voltage DIN

Power (DIN, D-Sub)

## Interface Dimensions Inserts Mini-Coax

Code 23

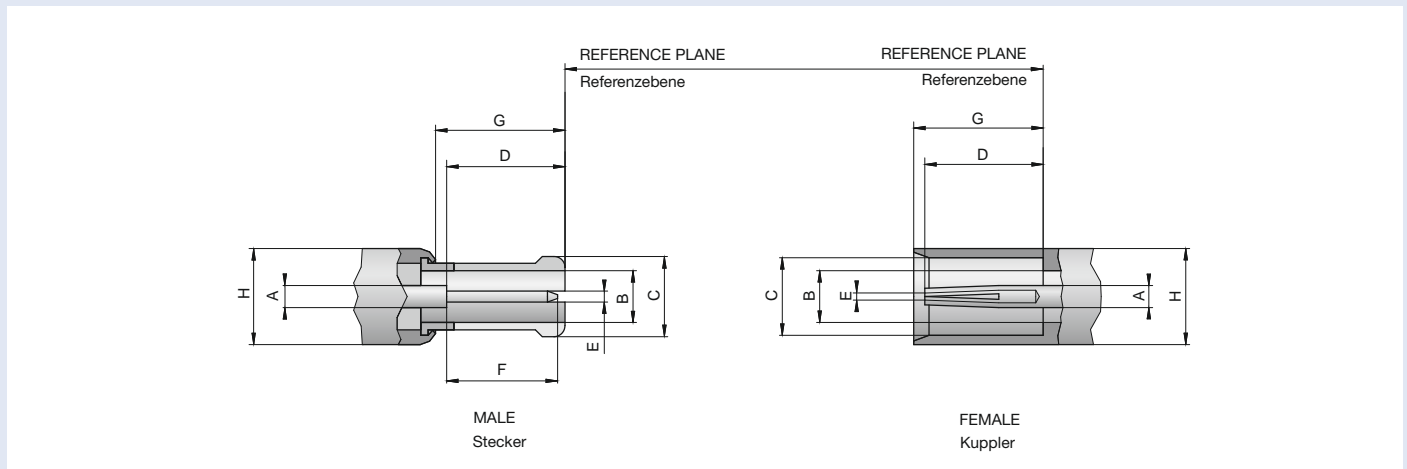

## Inserts Mini-Coax

dimension [mm]	Male   Stecker		Female   Kuppler	
	min.	max.	min.	max.
A	0.60 nom.		0.60 nom.	
B	1.40 nom.		1.40 nom.	
C	1)		2.10	2.125
D	3.20			3.20
E	0.30	0.33	2)	
F	3.00			
G		3.50	3.50	
H		2.65		2.65

1) resilient for contact with jack dimensions C

2) resilient, dimension to meet electrical and mechanical requirements

Mini-Coax Inserts - miniature coaxial connectors - are characterized by high mechanical and electrical stability and very low space requirements. They are mainly used in board-to-board and cable-to-board connections, hybrid and circular connectors - applications with demand for high density packaging at high-speed signal transmission rates.

*Mini-Coax-Einsätze sind Miniatur-Koaxial-Steckverbinder mit hoher mechanischer und elektrischer Stabilität für Anwendungen bis 6 GHz. Sie werden eingesetzt in Board-to-Board- und Cable-to-Board-Verbindungen, Mischleisten und Rundsteckverbindern - Anwendungen, die bei hoher Packungsdichte hohe Übertragungsgeschwindigkeiten erfordern.*

## Features

Interface according to Rosenberger Mini-Coax

Frequency range DC to 6 GHz

Return loss (cable connector straight)  $\geq 28$  dB @ 6 GHz

Impedance 50  $\Omega$

Plug-in/Snap-in Metral chassis

Connector pitch 2 mm, IEC 917

## Product Range

Cable connectors

PCB connectors (solder, press-fit versions)

Mini-Power Inserts

Adaptors

Extraction tools

Further connectors are available on request

## Technical Data Inserts Mini-Coax

## Code 23

<b>Applicable standards   Anwendbare Normen</b>	
Interface according to   <i>Interface gemäß</i>	Rosenberger Mini-Coax
Quality tested according to   <i>Qualitätsprüfung gemäß</i>	IEC 60068
<b>Electrical data   Elektrische Daten</b>	
Impedance   <i>Wellenwiderstand</i>	50 Ω
Frequency range   <i>Frequenzbereich</i>	DC to 6 GHz
Return loss (cable connector straight)   <i>Rückflussdämpfung (Kabelsteckverbinder gerade)</i>	≥ 28 dB @ DC to 1 GHz ≥ 24 dB @ 1 GHz to 3 GHz ≥ 16 dB @ 3 GHz to 6 GHz
Insertion loss   <i>Dämpfung</i>	≤ 0.1 x √f(GHz) dB
Insulation resistance   <i>Isolationswiderstand</i>	≥ 1 GΩ
Center contact resistance   <i>Übergangswiderstand Innenleiter</i>	≤ 10 mΩ
Outer contact resistance   <i>Übergangswiderstand Außenleiter</i>	≤ 3 mΩ
Test voltage   <i>Prüfspannung</i>	750 V rms
Working voltage   <i>Betriebsspannung</i>	500 V rms
RF leakage   <i>Schirmdämpfung</i>	≥ 80 dB @ DC to 1 GHz ≥ 60 dB @ 1 GHz to 4 GHz
<b>Mechanical data   Mechanische Daten</b>	
Mating cycles   <i>Steckzyklen</i>	≥ 500
Engagement force   <i>Steckkraft</i>	1 N to 4 N
Disengagement force   <i>Ziehkraft</i>	1 N to 4 N
<b>Environmental data   Umweltdaten</b>	
Temperature range   <i>Temperaturbereich</i>	-40 °C to +85 °C
Dry heat   <i>Trockene Wärme</i>	IEC 60068-2-2
Damp heat   <i>Feuchte Wärme</i>	IEC 60068-2-78
Climatic category   <i>Klimakategorie</i>	IEC 60068-2-1 40/85/21
Shock   <i>Schock</i>	IEC 60068-2-27 (50g halfsinus 2 shocks/axis during 11 sec.)
Max. soldering temperature (PCB connectors)   <i>Max. Löttemperatur (Leiterplattensteckverbinder)</i>	IEC 61760-1, +260 °C for 10 sec.
<b>Materials   Materialien</b>	
Spring loaded contact parts   <i>Federnde Kontaktteile</i>	CuBe, Au plating
Center contact   <i>Innenleiter</i>	CuBe, Au plating
Outer contact   <i>Außenleiter</i>	CuZn, Au plating
Crimping ferrule   <i>Crimphülse</i>	Soft copper, Au plating
Dielectric   <i>Dielektrikum</i>	PTFE

Rosenberger-connectors fulfill in principle the indicated data of the Technical Data. Individual values of connectors may deviate depending upon application, design, type of cable, assembly method and execution. Specific data sheets for particular products can be provided on request from your Rosenberger sales partner.

Rosenberger-Steckverbinder erfüllen grundsätzlich die in den Technischen Daten angegebenen Daten. Je nach Anwendung, Bauart, Kabeltyp, Montageart und -ausführung können einzelne Werte von Steckverbindern hiervon abweichen. Spezifische Datenblätter zu einzelnen Produkten erhalten Sie auf Anfrage von Ihrem Rosenberger-Ansprechpartner.

## Cable Connectors - Flexible Cables

Straight Plug, crimp

Flexible Cables

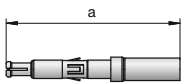
Ordering Number	Remarks	Cable Group	Assembly Instruction	Crimp Inserts	Packing Unit	
23 S 172-102 L5	a = 22.1 mm for 75 Ω cables	02	23 A	11 W 152-402	100	

Straight Plug, solder crimp

Flexible Cables

Ordering Number	Cable Group	Assembly Instruction	Crimp Inserts	Packing Unit	
23 S 102-301 L5	01	23 A	11 W 150-101	100	

Right Angle Plug, solder crimp

Flexible Cables

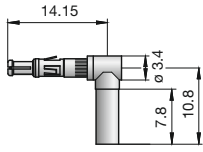
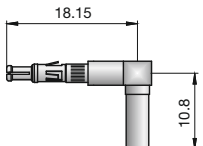
Ordering Number	Cable Group	Assembly Instruction	Crimp Inserts	Packing Unit	
23 S 201-301 L5	01	23 B	11 W 150-101	100 blister	
23 S 201-302 L5	02	23 B	11 W 152-102	100 blister	
23 S 202-301 L5	01	23 B	11 W 150-101	100 blister	
23 S 202-302 L5	02	23 B	11 W 152-102	100 blister	

Straight Jack, crimp

Flexible Cables

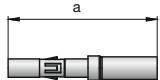
Ordering Number	Remarks	Cable Group	Assembly Instruction	Crimp Inserts	Packing Unit	
23 K 101-101 L5	a = 21.1 mm	01	23 A	11 W 150-401	100	
23 K 101-102 L5	a = 22.3 mm	02	23 A	11 W 152-402	100	
23 K 171-102 L5	a = 22.3 mm for 75 Ω cables	02, 75 Ω	23 A	11 W 152-402	100	

**PCB Connectors - Solder Pin**

Straight Plug, PCB

Solder Pin

Ordering Number	Remarks	Panel Piercing / PCB Layout	Packing Unit
23 S 101-400 L5	a = 2.0 mm, l = 9.8 mm, round pins	B 48	100 blister
23 S 102-400 L5	a = 2.5 mm, l = 10.3 mm, round pins	B 48	100 blister
23 S 104-400 L5	a = 3.0 mm, l = 10.8 mm, round pins	B 48	100 blister

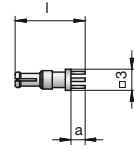

Right Angle Plug, PCB

Solder Pin

Ordering Number	Remarks	Panel Piercing / PCB Layout	Packing Unit
23 S 201-400 L5	a = 3.8 mm, round pins	B 48	100 blister
23 S 203-400 L5	a = 2.8 mm, round pins	B 48	100 blister
23 S 205-400 L5	a = 2.1 mm, round pins	B 48	100 blister

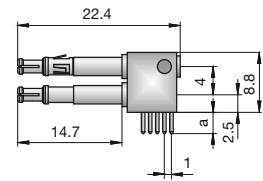

Right Angle Jack, PCB

Solder Pin

Ordering Number	Remarks	Panel Piercing / PCB Layout	Packing Unit
23 K 201-400 L5	a = 3.8 mm, round pins	B 48	100 blister
23 K 203-400 L5	a = 2.8 mm, round pins	B 48	100 blister
23 K 205-400 L5	a = 2.1 mm, round pins	B 48	100 blister
23 K 202-400 L5	a = 3.8 mm, round pins	B 48	100 blister
23 K 204-400 L5	a = 2.8 mm, round pins	B 48	100 blister
23 K 206-400 L5	a = 2.1 mm, round pins	B 48	100 blister

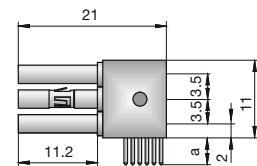
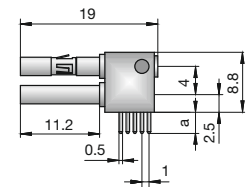

Inserts

## PCB Connectors - Press-fit

Straight Plug, PCB

Press-fit

Ordering Number	Panel Piercing / PCB Layout	Packing Unit	
23 S 101-40P L5	B 78	100 blister	

Right Angle Plug, PCB

Press-fit

Ordering Number	Panel Piercing / PCB Layout	Packing Unit	
23 S 201-40P L5	B 78	100 blister	

## Mini-Power

Right Angle Plug, PCB

Mini-Power

Ordering Number	Remarks	Panel Piercing / PCB Layout	Packing Unit	
23 S 201-410 L	a = 2.5 mm; b = 18.75 mm Power 10 A	B 48	100 blister	
23 S 202-410 L	a = 6.5 mm; b = 20.75 mm Power 10 A	B 48	100 blister	



Straight Jack, solder

Mini-Power

Ordering Number	Remarks	Packing Unit	
23 K 101-210 L	Power 10 A	100 blister	

**Adaptors**

Bullets

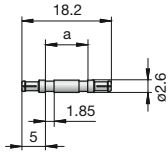
Ordering Number	Remarks	Packing Unit	
23 S 101-S00 L5	a = 5.05 mm, panel 3.2	1	
23 S 102-S00 L5	a = 4.25 mm, panel 2.4	1	
23 S 104-S00 L5	a = 5.85 mm, panel 4.0	1	
23 S 105-S00 L5	a = 6.65 mm, panel 4.8	1	
23 S 121-S00 L5	a = 9.0 mm, panel 3.2	1	
23 S 122-S00 L5	a = 8.2 mm, panel 2.4	1	
23 S 123-S00 L5	a = 7.4 mm, panel 1.6	1	
23 S 124-S00 L5	a = 9.8 mm, panel 4.0	1	
23 S 126-S00 L5	a = 11.4 mm, panel 5.6	1	
23 S 122-S10 L	a = 8.2 mm, panel 2.2 mm Power 10 A	1	

**Special Tools**

Extraction Tools

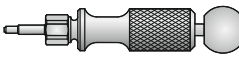
Ordering Number	Remarks	Packing Unit	
11 W 108-K00	for Metral mini coax female inserts	1	
11 W 108-K01	extra sleeve for replacement	1	
11 W 108-S00	for Metral mini coax male inserts	1	
11 W 108-S01	extra sleeve for replacement	1	



## Interface Dimensions Inserts Coax D-Sub

Code 55

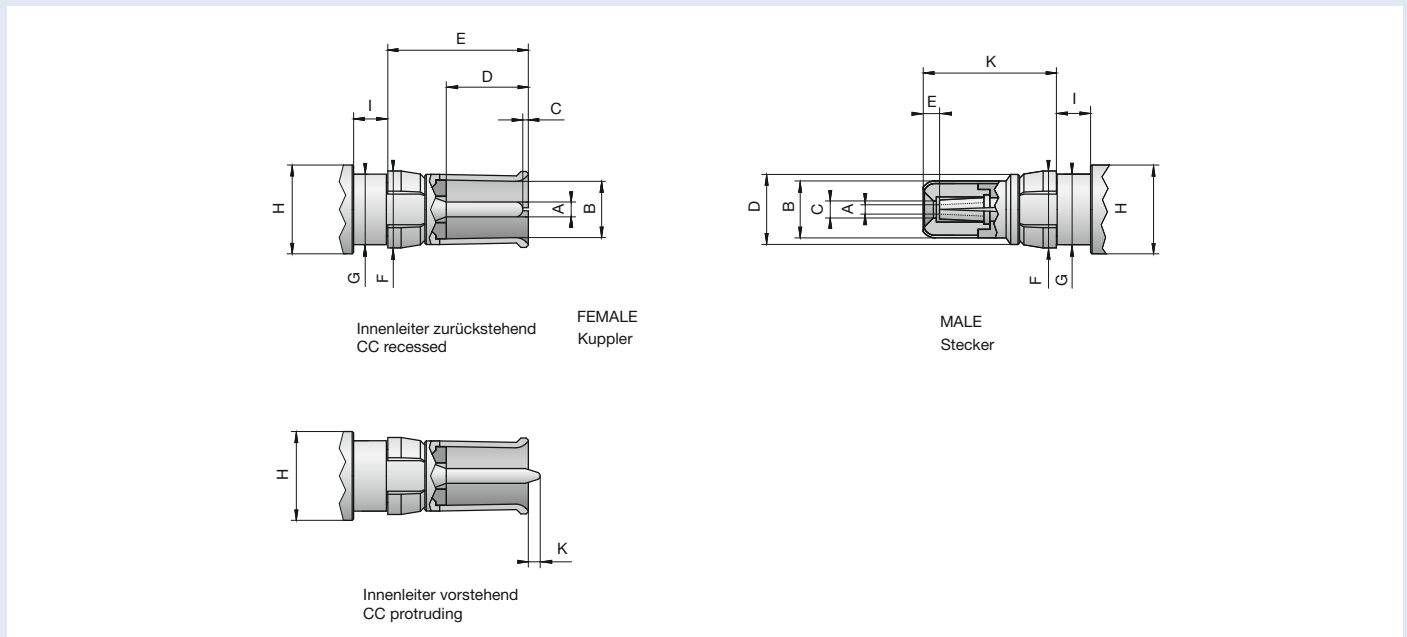

## Inserts Coax D-Sub

dimension [mm]	Female   Kuppler		Male   Stecker	
	min.	max.	min.	max.
A	0.99	1.01		1) 2)
B		1) 2)		3.85
C	0.10	0.50		1.20
D	5.45	5.65		4.75
E	9.35	9.50	0.90	1.10
F		5.25		5.25
G	4.76	4.79	4.76	4.79
H		6.00 3)		6.00 3)
I	2.22	2.40	2.22	2.40
K	0.40	0.80	8.85	9.00

1) contact diameters refer to 50 Ω

2) resilient, dimension to meet electrical and mechanical requirements

3) square shape optional

D-Sub Coax Inserts are designed for applications up to 2 GHz in rack / plug-in chassis technology as well as for printed circuit boards. The contacts are installed by snap-in method, a combination with high current and high voltage connectors is possible.

### Please note - reverse polarity design

Male connectors are equipped with female center contacts, female connectors with male center contacts.

*D-Sub-Koaxeinsätze sind für Anwendungen bis 2 GHz in Gestell-Einschubtechnik sowie für integrierte Schaltungen konzipiert. Die Montage in Leisten erfolgt durch Einrasten, eine Kombination mit Hochstrom- und Hochspannungs-Steckverbindern ist möglich.*

### Achtung - Reverse Polarity-Ausführung:

*Die Stecker sind mit einem Buchsen-Innenleiter, die Kuppler mit einem Stift-Innenleiter ausgestattet.*

## Features

Interface according to D-Sub connectors

Frequency range DC to 2 GHz

Return loss (cable connector straight) ≥ 14 dB @ 2 GHz

Impedance 50 Ω

Plug-in/Snap-in D-Sub chassis

Inverse center contact

## Product Range

Cable connectors

PCB connectors (solder versions)

Extraction tools

Further connectors are available on request

## Technical Data Inserts Coax D-Sub

## Code 55

<b>Applicable standards   Anwendbare Normen</b>	
Interface according to   <i>Interface gemäß</i>	D-Sub
Quality tested according to   <i>Qualitätsprüfung gemäß</i>	IEC 60068
<b>Electrical data   Elektrische Daten</b>	
Impedance   <i>Wellenwiderstand</i>	50 Ω
Frequency range   <i>Frequenzbereich</i>	DC to 2 GHz
Return loss (cable connector straight)   <i>Rückflussdämpfung (Kabelsteckverbinder gerade)</i>	≥ 30 dB @ DC to 0.1 GHz ≥ 20 dB @ 0.1 GHz to 0.5 GHz ≥ 14 dB @ 0.5 GHz to 2 GHz
Insertion loss   <i>Dämpfung</i>	≤ 0.1 x √f(GHz) dB
Insulation resistance   <i>Isolationswiderstand</i>	≥ 10 GΩ
Center contact resistance   <i>Kontaktwiderstand Innenleiter</i>	≤ 10 mΩ
Outer contact resistance   <i>Kontaktwiderstand Außenleiter</i>	≤ 3 mΩ
Test voltage   <i>Prüfspannung</i>	1500 V rms
Working voltage   <i>Betriebsspannung</i>	500 V rms
RF-leakage   <i>Schirmdämpfung</i>	≥ 80 dB @ DC to 0.5 GHz ≥ 65 dB @ 0.5 GHz to 1.5 GHz
<b>Mechanical data   Mechanische Daten</b>	
Mating cycles   <i>Steckzyklen</i>	≥ 50
Connector captivation in plastic   <i>Haltekraft des Steckverbinders in Kunststoff</i>	≥ 52 N
Center contact captivation   <i>Innenleiter Haltekraft</i>	axial: ≥ 10 N
Engagement force   <i>Steckkraft</i>	≤ 10 N
Disengagement force   <i>Ziehkraft</i>	≤ 10 N
<b>Environmental data   Umweltdaten</b>	
Temperature range   <i>Temperaturbereich</i>	-55 °C to +125 °C
Dry heat   <i>Trockene Wärme</i>	IEC 60068-2-2
Damp heat   <i>Feuchte Wärme</i>	IEC 60068-2-78
Climatic category   <i>Klimakategorie</i>	IEC 60068-2-1 55/125/21
Max. soldering temperature (PCB connectors)   <i>Max. Löttemperatur (Leiterplattensteckverbinder)</i>	IEC 61760-1, +260 °C for 10 sec.
<b>Materials   Materialien</b>	
Spring loaded contact parts   <i>Federnde Kontaktteile</i>	CuBe, Au plating
Center contact   <i>Innenleiter</i>	CuZn, Au plating
Outer contact   <i>Außenleiter</i>	CuZn, Au plating
Crimping ferrule   <i>Crimphülse</i>	Soft copper, Au plating
Clip   <i>Clip</i>	CuBe, Ni plating
Dielectric   <i>Dielektrikum</i>	PTFE

Rosenberger-connectors fulfill in principle the indicated data of the Technical Data. Individual values of connectors may deviate depending upon application, design, type of cable, assembly method and execution. Specific data sheets for particular products can be provided on request from your Rosenberger sales partner.

*Rosenberger-Steckverbinder erfüllen grundsätzlich die in den Technischen Daten angegebenen Daten. Je nach Anwendung, Bauart, Kabeltyp, Montageart und -ausführung können einzelne Werte von Steckverbindern hiervon abweichen. Spezifische Datenblätter zu einzelnen Produkten erhalten Sie auf Anfrage von Ihrem Rosenberger-Ansprechpartner.*

**Cable Connectors - Semi-Rigid Cables**

Right Angle Plug, solder

Semi-Rigid Cables

Ordering Number	Cable Group	Assembly Instruction	Packing Unit
55 S 201-270 L5	70	55 E	1

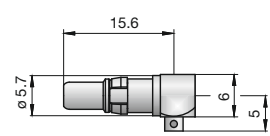

**Cable Connectors - Flexible Cables**

Straight Plug, solder-crimp

Flexible Cables

Ordering Number	Remarks	Cable Group	Assembly Instruction	Crimp Inserts	Packing Unit
55 S 101-301 L5		01	55 A	11 W 150-101	100
55 S 101-302 L5		02	55 A	11 W 150-102	100
55 S 101-303 L5		03	55 A	11 W 150-103	1
55 S 101-306 L5	length 26.6 mm	06	55 A3	11 W 150-106	1

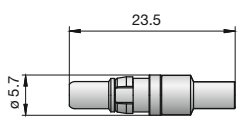

Right Angle Plug, solder-crimp

Flexible Cables

Ordering Number	Cable Group	Assembly Instruction	Crimp Inserts	Packing Unit
55 S 201-301 L5	01	55 B	11 W 150-101	100
55 S 201-302 L5	02	55 B	11 W 150-102	100

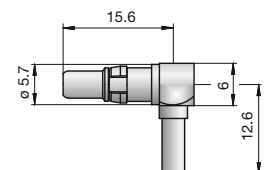

Straight Jack, solder-crimp

Flexible Cables

Ordering Number	Remarks	Cable Group	Assembly Instruction	Crimp Inserts	Packing Unit
55 K 101-301 L5		01	55 A	11 W 150-101	100
55 K 101-302 L5		02	55 A	11 W 150-102	100
55 K 101-303 L5		03	55 A	11 W 150-103	100
55 K 101-306 L5	length 27.1 mm	06	55 A3	11 W 150-106	100

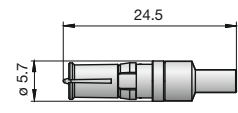
55 K 151-301 L5		01	55 A	11 W 150-101	100
55 K 151-302 L5		02	55 A	11 W 150-102	100
55 K 151-303 L5		03	55 A	11 W 150-103	100

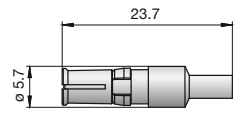

Right Angle Jack, solder-crimp

Flexible Cables

Ordering Number	Cable Group	Assembly Instruction	Crimp Inserts	Packing Unit	
55 K 201-301 L5	01	55 B	11 W 150-101	100	
55 K 201-302 L5	02	55 B	11 W 150-102	1	
55 K 252-302 L5	02	55 B	11 W 150-102	1	
55 K 252-303 L5	03	55 B	11 W 150-103	100	

Straight Jack, solder tag

Ordering Number	Packing Unit	
55 K 151-200 L5	100	

### PCB Connectors - Solder Pin

Right Angle Plug, PCB

Solder Pin

Ordering Number	Panel Piercing / PCB Layout	Packing Unit	
55 S 202-400 L5	B 30	100 blister	

### Special Tools

Extraction Tools

Ordering Number	Remarks	Packing Unit	
11 W 101-000	for D-Sub inserts	1	
11 W 101-001	extra sleeve for replacement	1	

Inserts

## Interface Dimensions Inserts Coax1.0-2.3 DIN 41626-T2, 50 Ω

**Code 45**

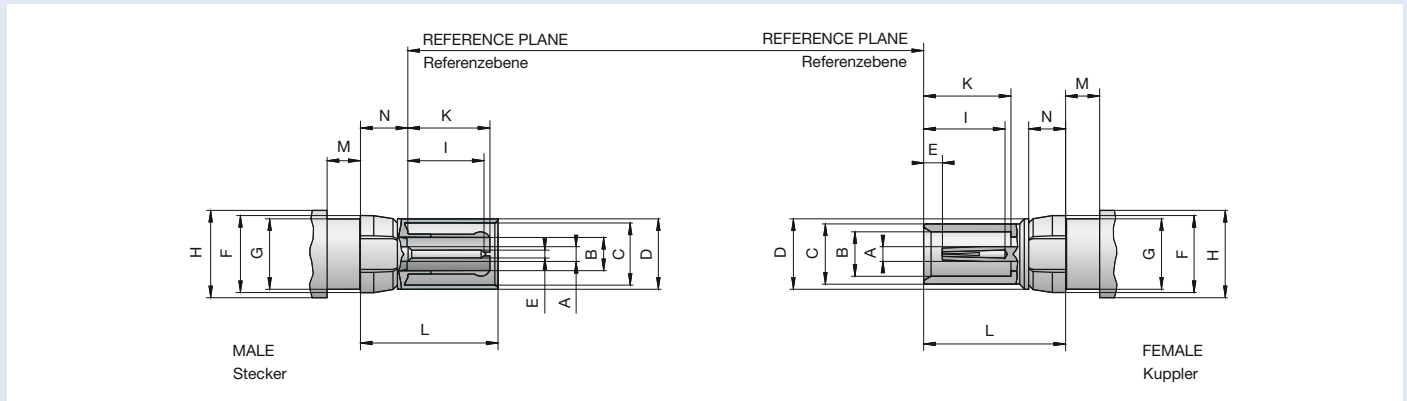

## Inserts Coax 1.0-2.3 DIN 41626-T2, 50 Ω

dimension [mm]	Male   Stecker		Female   Kuppler	
	min.	max.	min.	max.
A		1.00		1.00 1) 2)
B		2.30 1) 2)	3.00	3.06
C	4.20	4.275	4.03	4.15
D	4.72	4.75	4.72	4.75
E	0.475	0.52	1.15	1.45
F		5.25		5.25
G	4.76	4.79	4.76	4.79
H		6.00 3)		6.00 3)
I	5.20	5.50	5.50	
K	5.40	5.70	5.80	5.90
L	9.25	9.35	9.50	9.60
M	2.22	2.40	2.22	2.40
N	3.05	3.20	2.45	2.50

1) contact diameters refer to 50 Ω

2) resilient, dimension to meet electrical and mechanical requirements

3) square shape optional

1.0-2.3 DIN 41626 Coax Inserts are designed for use in mixed card edge connections in accordance to DIN 41612. The maximum frequency is approx. 2 GHz, small dimensions enable high packaging densities. The contacts are installed by snap-in method, a combination with high current and high voltage connectors is possible.

1.0-2.3 DIN 41626 Koax-Einsätze sind für den Einsatz in Mischleisten nach DIN 41612 ausgelegt. Die max. Frequenz liegt bei 2 GHz, die geringe Baugröße ermöglicht hohe Packungsdichten. Die Montage in Leisten erfolgt durch Einrasten, eine Kombination mit Hochstrom- und Hochspannungs-Steckverbindern ist möglich.

## Features

Interface according to DIN 41626-T2, BS 9525 F0011

Frequency range DC to 2 GHz

Return loss (cable connector straight) ≥ 20 dB (typ.)

Impedance 50 Ω

Plug-in/Snap-in DIN 41612 chassis

## Product Range

Cable connectors

PCB connectors (solder, press-fit versions)

Adaptors

Extraction tools

Further connectors are available on request

**Technical Data Inserts Coax 1.0-2.3  
DIN 41626-T2, 50 Ω**
**Code 45**

<b>Applicable standards   Anwendbare Normen</b>	
Interface according to   <i>Interface gemäß</i>	DIN 41626-T2, BS 9525 F0011
Quality tested according to   <i>Qualitätsprüfung gemäß</i>	IEC 60068
<b>Electrical data   Elektrische Daten</b>	
Impedance   <i>Wellenwiderstand</i>	50 Ω
Frequency range   <i>Frequenzbereich</i>	DC to 2 GHz
Return loss (cable connector straight)   <i>Rückflussdämpfung (Kabelsteckverbinder gerade)</i>	≥ 20 dB (typ.)
Insertion loss   <i>Dämpfung</i>	≤ 0.1 x √f(GHz) dB
Insulation resistance   <i>Isolationswiderstand</i>	≥ 2 GΩ
Center contact resistance   <i>Übergangswiderstand Innenleiter</i>	≤ 10 mΩ
Outer contact resistance   <i>Übergangswiderstand Außenleiter</i>	≤ 3 mΩ
Test voltage   <i>Prüfspannung</i>	750 V rms
Working voltage   <i>Betriebsspannung</i>	250 V rms
RF-leakage   <i>Schirmdämpfung</i>	≥ 80 dB @ DC to 0.5 GHz ≥ 65 dB @ 0.5 GHz to 1.5 GHz
<b>Mechanical data   Mechanische Daten</b>	
Mating cycles   <i>Steckzyklen</i>	≥ 500
Connector captivation in plastic   <i>Haltekraft des Steckverbinders in Kunststoff</i>	≥ 52 N
Center contact captivation   <i>Innenleiter Haltekraft</i>	axial: ≥ 10 N
Engagement force   <i>Steckkraft</i>	≤ 10 N
Disengagement force   <i>Ziehkraft</i>	≤ 10 N
<b>Environmental data   Umweltdaten</b>	
Temperature range   <i>Temperaturbereich</i>	-55 °C to +125 °C
Dry heat   <i>Trockene Wärme</i>	IEC 60068-2-2
Damp heat   <i>Feuchte Wärme</i>	IEC 60068-2-78
Climatic category   <i>Klimakategorie</i>	IEC 60068-2-1 55/125/21
Max. soldering temperature (PCB connectors)   <i>Max. Löttemperatur (Leiterplattensteckverbinder)</i>	IEC 61760-1, +260 °C for 10 sec.
<b>Materials   Materialien</b>	
Spring loaded contact parts   <i>Federnde Kontaktteile</i>	CuBe, Au plating
Center contact   <i>Innenleiter</i>	CuZn, Au plating
Outer contact   <i>Außenleiter</i>	CuZn, Au plating
Crimping ferrule   <i>Crimphülse</i>	Soft copper, Au plating
Clip   <i>Clip</i>	CuBe, Ni plating
Dielectric   <i>Dielektrikum</i>	PTFE

Rosenberger-connectors fulfill in principle the indicated data of the Technical Data. Individual values of connectors may deviate depending upon application, design, type of cable, assembly method and execution. Specific data sheets for particular products can be provided on request from your Rosenberger sales partner.

*Rosenberger-Steckverbinder erfüllen grundsätzlich die in den Technischen Daten angegebenen Daten. Je nach Anwendung, Bauart, Kabeltyp, Montageart und -ausführung können einzelne Werte von Steckverbindern hiervon abweichen. Spezifische Datenblätter zu einzelnen Produkten erhalten Sie auf Anfrage von Ihrem Rosenberger-Ansprechpartner.*

**Cable Connectors - Semi-Rigid Cables**

Straight Plug, solder

Semi-Rigid Cables

Ordering Number	Cable Group	Assembly Instruction	Packing Unit
45 S 102-270 L5	70	59 K	1, 100
45 S 102-271 L5	71	59 K	1, 100

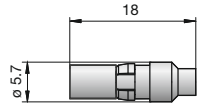

Right Angle Plug, solder

Semi-Rigid Cables

Ordering Number	Cable Group	Assembly Instruction	Packing Unit
45 S 202-271 L5	71	55 E	1, 100

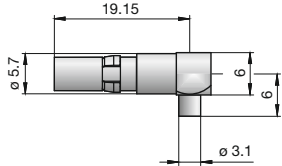

Straight Jack, solder

Semi-Rigid Cables

Ordering Number	Cable Group	Assembly Instruction	Packing Unit
45 K 102-270 L5	70	59 K	1, 100
45 K 102-271 L5	71	59 K	1, 100

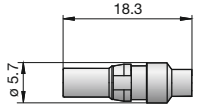

Right Angle Jack, solder

Semi-Rigid Cables

Ordering Number	Remarks	Cable Group	Assembly Instruction	Packing Unit
45 K 201-270 L5	a = 2.6 mm; b = 5.0 mm	70	55 E	1, 100
45 K 201-271 L5	a = 3.1 mm; b = 6.0 mm	71	55 E	1, 100

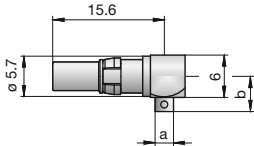

**Cable Connectors - Flexible Cables**

Straight Plug, crimp

Flexible Cables

Ordering Number	Cable Group	Assembly Instruction	Crimp Inserts	Packing Unit
45 S 105-101 L5	01	45 A1	11 W 150-402	1, 100
45 S 101-102 L5	02	45 A1	11 W 150-402	1, 100
45 S 101-103 L5	03	45 A1	11 W 150-403	1, 100

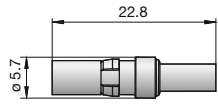

Right Angle Plug, solder-crimp

Flexible Cables

Ordering Number	Cable Group	Assembly Instruction	Crimp Inserts	Packing Unit	
45 S 201-301 L5	01	55 B	11 W 150-101	1, 100	
45 S 201-302 L5	02	55 B	11 W 150-102	1, 100	
45 S 201-303 L5	03	55 B	11 W 150-103	1, 100	
45 S 202-302 L5	02	55 B	11 W 150-102	1, 100	
45 S 202-303 L5	03	55 B	11 W 150-103	1, 100	

Straight Jack, crimp

Flexible Cables

Ordering Number	Cable Group	Assembly Instruction	Crimp Inserts	Packing Unit	
45 K 105-101 L5	01	45 A1	11 W 150-402	1, 100	
45 K 101-102 L5	02	45 A1	11 W 150-402	1, 100	
45 K 101-103 L5	03	45 A1	11 W 150-403	1, 100	
45 K 106-101 L5	01	45 A1	11 W 150-401	1, 100	
45 K 106-102 L5	02	45 A1	11 W 150-402	1, 100	
45 K 106-103 L5	03	45 A1	11 W 150-403	1, 100	

Right Angle Jack, solder-crimp

Flexible Cables

Ordering Number	Cable Group	Assembly Instruction	Crimp Inserts	Packing Unit	
45 K 201-301 L5	01	55 B	11 W 150-101	1, 100	
45 K 201-302 L5	02	55 B	11 W 150-102	1, 100	
45 K 201-303 L5	03	55 B	11 W 150-103	1, 100	



**PCB Connectors - Solder Pin**

Straight Plug, PCB

Solder Pin

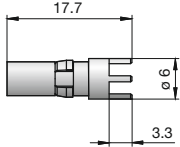
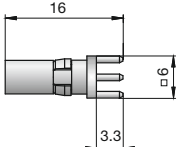
Ordering Number	Remarks	Panel Piercing / PCB Layout	Packing Unit	
45 S 101-400 L5	round pins	B 39	100 blister	
45 S 106-400 L5	round pins	B 30c	100 blister	

Right Angle Plug, PCB

Solder Pin

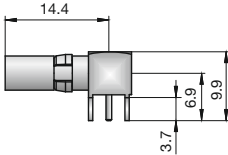
Ordering Number	Remarks	Panel Piercing / PCB Layout	Packing Unit	
45 S 201-400 L5	round pins	B 30c	100 blister	

Straight Jack, PCB

Solder Pin

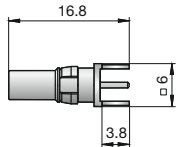
Ordering Number	Panel Piercing / PCB Layout	Packing Unit	
45 K 106-400 L5	B 30c	100 blister	

Right Angle Jack, PCB

Solder Pin

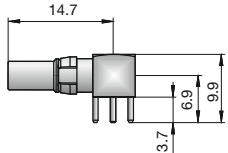
Ordering Number	Remarks	Panel Piercing / PCB Layout	Packing Unit	
45 K 201-400 L5	round pins	B 30c	100 blister	

**PCB Connectors - Press-fit**

Straight Plug, PCB

Press-fit

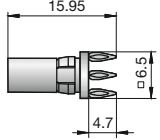
Ordering Number	Panel Piercing / PCB Layout	Packing Unit	
45 S 102-40P L5	B 79	100 blister	

Right Angle Jack, PCB

Press-fit

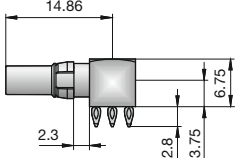
Ordering Number	Panel Piercing / PCB Layout	Packing Unit	
45 K 20A-40P L5	B 87	100 blister	

**Adaptors**

Adaptors (In Series)

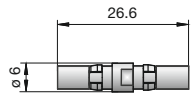
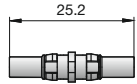
Ordering Number	Version	Remarks	Packing Unit	
45 S 101-S00 L5	straight	1.0-2.3 DIN 41626 male - male	1	
45 K 101-K00 L5	straight	1.0-2.3 DIN 41626 female - female	1	

Adaptors (Inter Series)

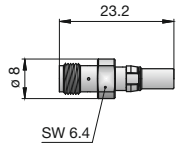
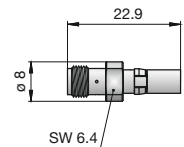
Ordering Number	Version	Remarks	Packing Unit	
32 K 145-K00 L5	straight	SMA female - 1.0-2.3 DIN 41626 female	1	
32 K 145-S00 L5	straight	SMA female - 1.0-2.3 DIN 41626 male	1	

### Special Tools

Extraction Tools

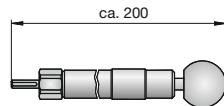
Ordering Number	Remarks	Packing Unit	
11 W 102-000	for DIN 41626 inserts	1	
11 W 102-001	extra sleeve for replacement	1	
11 W 103-000	for DIN 41626 inserts, extra-long version	1	

**Interface Dimensions Inserts Coax 1.0-2.3  
DIN 41626-T2, 75 Ω , interm. 50 Ω**

**Code 75**

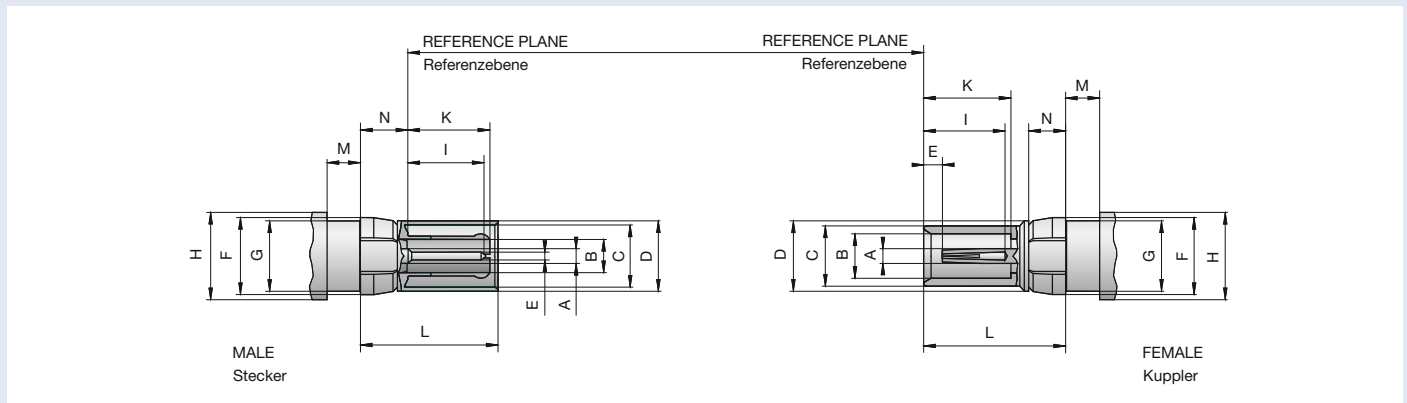

**Inserts Coax 1.0-2.3 DIN 41626-T2, 75 Ω ,  
interm. 50 Ω**

dimension [mm]	Male   Stecker		Female   Kuppler	
	min.	max.	min.	max.
A		1.00		1.00 1) 2)
B		2.30 1) 2)	3.00	3.06
C	4.20	4.275	4.03	4.15
D	4.72	4.75	4.72	4.75
E	0.475	0.52	1.15	1.45
F		5.25		5.25
G	4.76	4.79	4.76	4.79
H		6.00 3)		6.00 3)
I	5.20	5.50	5.50	
K	5.40	5.70	5.80	5.90
L	9.25	9.35	9.50	9.60
M	2.22	2.40	2.22	2.40
N	3.05	3.20	2.45	2.50

1) contact diameters refer to 50 Ω

2) resilient, dimension to meet electrical and mechanical requirements

3) square shape optional

1.0-2.3 Coax Inserts, 75 Ω , are similar to DIN 41626-T2 and are designed for use in mixed card edge connections in accordance to DIN 41612. The maximum frequency is approx. 1.5 GHz, small dimensions enable high packing densities. The contacts are installed by snap-in method, a combination with high current and high voltage connectors is possible.

50 Ω and 75 Ω versions are intermateable.

Die 75 Ω -Ausführungen sind ähnlich der Norm DIN 41626-T2 und für den Einsatz in Mischleisten, ähnlich DIN 41612, ausgelegt. Die max. Frequenz liegt bei 1,5 GHz, die geringe Baugröße ermöglicht hohe Packungsdichten. Die Montage in Leisten erfolgt durch Einrasten, eine Kombination mit Hochstrom- und Hochspannungs-Steckverbindern ist möglich.

50 Ω und 75 Ω -Ausführungen sind steckkompatibel.

**Features**

Interface according to DIN 41626-T2 (intermateable with 50 Ω )

Frequency range DC to 1.5 GHz

Return loss (cable connector straight) ≥ 20 dB (typ.)

Impedance 50 Ω

Plug-in/Snap-in DIN 41612 chassis

**Product Range**

Cable connectors

PCB connectors (solder version)

Further connectors are available on request

**Technical Data Inserts Coax 1.0-2.3,  
DIN 41626-T2, 75 Ω , interm. 50 Ω****Code 75**

<b>Applicable standards   Anwendbare Normen</b>	
Interface according to   <i>Interface gemäß</i>	DIN 41626-T2 (intermateable with 50 Ω)
Quality tested according to   <i>Qualitätsprüfung gemäß</i>	IEC 60068
<b>Electrical data   Elektrische Daten</b>	
Impedance   <i>Wellenwiderstand</i>	75 Ω
Frequency range   <i>Frequenzbereich</i>	DC to 1.5 GHz
Return loss (cable connector straight)   <i>Rückflussdämpfung (Kabelsteckverbinder gerade)</i>	≥ 20 dB (typ.)
Insertion loss   <i>Dämpfung</i>	≤ 0.1 x √f(GHz) dB
Insulation resistance   <i>Isolationswiderstand</i>	≥ 0.2 GΩ
Center contact resistance   <i>Übergangswiderstand Innenleiter</i>	≤ 10 mΩ
Outer contact resistance   <i>Übergangswiderstand Außenleiter</i>	≤ 3 mΩ
Test voltage   <i>Prüfspannung</i>	750 V rms
Working voltage   <i>Betriebsspannung</i>	250 V rms
RF-leakage   <i>Schirmdämpfung</i>	≥ 80 dB @ DC to 0.5 GHz ≥ 65 dB @ 0.5 GHz to 1.5 GHz
<b>Mechanical data   Mechanische Daten</b>	
Mating cycles   <i>Steckzyklen</i>	≥ 500
Connector captivation in plastic   <i>Haltekraft des Steckverbinders in Kunststoff</i>	≥ 52 N
Center contact captivation   <i>Innenleiter Haltekraft</i>	axial: ≥ 10 N
Engagement force   <i>Steckkraft</i>	≤ 10 N
Disengagement force   <i>Ziehkraft</i>	≤ 10 N
<b>Environmental data   Umweltdaten</b>	
Temperature range   <i>Temperaturbereich</i>	-55 °C to +125 °C
Dry heat   <i>Trockene Wärme</i>	IEC 60068-2-2
Damp heat   <i>Feuchte Wärme</i>	IEC 60068-2-78
Climatic category   <i>Klimakategorie</i>	IEC 60068-2-1 55/125/21
Max. soldering temperature (PCB connectors)   <i>Max. Löttemperatur (Leiterplattensteckverbinder)</i>	IEC 61760-1, +260 °C for 10 sec.
<b>Materials   Materialien</b>	
Spring loaded contact parts   <i>Federnde Kontaktteile</i>	CuBe, Au plating
Center contact   <i>Innenleiter</i>	CuZn, Au plating
Outer contact   <i>Außenleiter</i>	CuZn, Au plating
Crimping ferrule   <i>Crimphülse</i>	Soft copper, Au plating
Clip   <i>Clip</i>	CuBe, Ni plating
Dielectric   <i>Dielektrikum</i>	PTFE

Rosenberger-connectors fulfill in principle the indicated data of the Technical Data. Individual values of connectors may deviate depending upon application, design, type of cable, assembly method and execution. Specific data sheets for particular products can be provided on request from your Rosenberger sales partner.

*Rosenberger-Steckverbinder erfüllen grundsätzlich die in den Technischen Daten angegebenen Daten. Je nach Anwendung, Bauart, Kabeltyp, Montageart und -ausführung können einzelne Werte von Steckverbindern hiervon abweichen. Spezifische Datenblätter zu einzelnen Produkten erhalten Sie auf Anfrage von Ihrem Rosenberger-Ansprechpartner.*

**Cable Connectors - Flexible Cables**

Straight Plug, full crimp

Flexible Cables

Ordering Number	Cable Group	Assembly Instruction	Crimp Inserts	Packing Unit	
75 S 101-102 L5	02	45 A1	11 W 150-402	1	

Right Angle Jack, solder-crimp

Flexible Cables

Ordering Number	Cable Group	Assembly Instruction	Crimp Inserts	Packing Unit	
75 K 208-302 L5	02	55 B	11 W 150-102	1	

**PCB Connectors - Solder Pin**

Right Angle Plug, PCB

Solder Pin

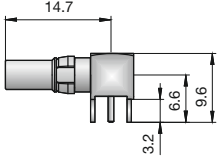
Ordering Number	Panel Piercing / PCB Layout	Packing Unit	
75 K 201-400 L5	B 30c	100 blister	



## Interface Dimensions Inserts Coax 0.8-2.7 DIN 41626-T2, 75 Ω

Code 745

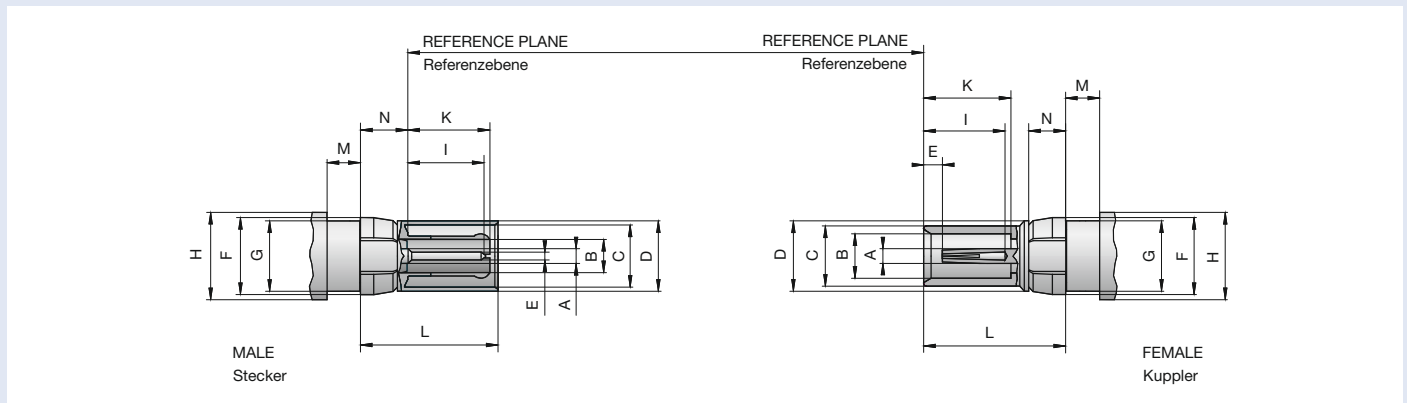

## Inserts Coax 0.8-2.7 DIN 41626-T2, 75 Ω

dimension [mm]	Male   Stecker		Female   Kuppler	
	min.	max.	min.	max.
A		0.77		0.77 1) 2)
B		2.70 1) 2)	3.35	3.38
C	4.35	4.38	4.30	4.33
D	4.76	4.79	4.72	4.75
E	0.37	0.41	1.15	1.45
F		5.25		5.25
G	4.76	4.79	4.76	4.79
H		6.00 3)		6.00 3)
I	5.20	5.50	5.50	
K	5.40	5.70	5.80	5.90
L	9.25	9.35	9.50	9.60
M	2.22	2.40	2.22	2.40
N	2.45	2.50	2.45	2.50

1) contact diameters refer to 75 Ω

2) resilient, dimension to meet electrical and mechanical requirements

3) square shape optional

0.8-2.7 Coax Inserts, 75 Ω, are similar to DIN 41626-T2 and are designed for use in mixed card edge connections in accordance to DIN 41612. The maximum frequency is approx. 1.5 GHz, small dimensions enable high packing densities. The contacts are installed by snap-in method, a combination with high current and high voltage connectors is possible.

50 Ω and 75 Ω versions are not intermateable.

0.8-2.7 Koax-Einsätze in 75 Ω sind ähnlich der Norm DIN 41626-T2 und für den Einsatz in Mischleisten nach DIN 41612 ausgelegt. Die max. Frequenz liegt bei 1,5 GHz, die geringe Baugröße ermöglicht hohe Packungsdichten. Die Montage in Leisten erfolgt durch Einrasten, eine Kombination mit Hochstrom- und Hochspannungs-Steckverbindern ist möglich.

50 Ω und 75 Ω-Ausführungen sind nicht steckkompatibel.

## Features

Interface according to DIN 41626-T2 (not intermateable with 50 Ω)

Frequency range DC to 1.5 GHz

Return loss (cable connector straight) ≥ 20 dB (typ.)

Impedance 50 Ω

Plug-in/Snap-in DIN 41612 chassis

## Product Range

Cable connectors

PCB connectors (solder versions)

Adaptors

Further connectors are available on request

**Technical Data Inserts Coax 0.8-2.7  
DIN 41626-T2, 75 Ω**
**Code 745**

<b>Applicable standards   Anwendbare Normen</b>	
Interface according to   <i>Interface gemäß</i>	DIN 41626-T2 (not intermateable with 50 Ω)
Quality tested according to   <i>Qualitätsprüfung gemäß</i>	IEC 60068
<b>Electrical data   Elektrische Daten</b>	
Impedance   <i>Wellenwiderstand</i>	75 Ω
Frequency range   <i>Frequenzbereich</i>	DC to 1.5 GHz
Return loss (cable connector straight)   <i>Rückflussdämpfung (Kabelsteckverbinder gerade)</i>	≥ 20 dB (typ.)
Insertion loss   <i>Dämpfung</i>	≤ 0.1 x √f(GHz) dB
Insulation resistance   <i>Isolationswiderstand</i>	≥ 0.2 GΩ
Center contact resistance   <i>Übergangswiderstand Innenleiter</i>	≤ 10 mΩ
Outer contact resistance   <i>Übergangswiderstand Außenleiter</i>	≤ 3 mΩ
Test voltage   <i>Prüfspannung</i>	750 V rms
Working voltage   <i>Betriebsspannung</i>	250 V rms
RF-leakage   <i>Schirmdämpfung</i>	≥ 80 dB @ DC to 0.5 GHz ≥ 65 dB @ 0.5 GHz to 1.5 GHz
<b>Mechanical data   Mechanische Daten</b>	
Mating cycles   <i>Steckzyklen</i>	≥ 500
Connector captivation in plastic   <i>Haltekraft des Steckverbinders in Kunststoff</i>	≥ 52 N
Center contact captivation   <i>Innenleiter Haltekraft</i>	axial: ≥ 10 N
Engagement force   <i>Steckkraft</i>	≤ 10 N
Disengagement force   <i>Ziehkraft</i>	≤ 10 N
<b>Environmental data   Umweltdaten</b>	
Temperature range   <i>Temperaturbereich</i>	-55 °C to +125 °C
Dry heat   <i>Trockene Wärme</i>	IEC 60068-2-2
Damp heat   <i>Feuchte Wärme</i>	IEC 60068-2-78
Climatic category   <i>Klimakategorie</i>	IEC 60068-2-1 55/125/21
Max. soldering temperature (PCB connectors)   <i>Max. Löttemperatur (Leiterplattensteckverbinder)</i>	IEC 61760-1, +260 °C for 10 sec.
<b>Materials   Materialien</b>	
Spring loaded contact parts   <i>Federnde Kontaktteile</i>	CuBe, Au plating
Center contact   <i>Innenleiter</i>	CuZn, Au plating
Outer contact   <i>Außenleiter</i>	CuZn, Au plating
Crimping ferrule   <i>Crimphülse</i>	Soft copper, Au plating
Clip   <i>Clip</i>	CuBe, Ni plating
Dielectric   <i>Dielektrikum</i>	PTFE

Rosenberger-connectors fulfill in principle the indicated data of the Technical Data. Individual values of connectors may deviate depending upon application, design, type of cable, assembly method and execution. Specific data sheets for particular products can be provided on request from your Rosenberger sales partner.

*Rosenberger-Steckverbinder erfüllen grundsätzlich die in den Technischen Daten angegebenen Daten. Je nach Anwendung, Bauart, Kabeltyp, Montageart und -ausführung können einzelne Werte von Steckverbindern hiervon abweichen. Spezifische Datenblätter zu einzelnen Produkten erhalten Sie auf Anfrage von Ihrem Rosenberger-Ansprechpartner.*

**Cable Connectors - Flexible Cables**

Straight Plug, solder-crimp

Flexible Cables

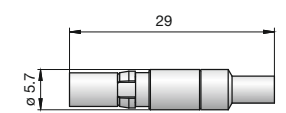
Ordering Number	Cable Group	Assembly Instruction	Crimp Inserts	Packing Unit	
745 S 101-302 L5	02	55 A	11 W 150-102	1	

Right Angle Plug, solder-crimp

Flexible Cables

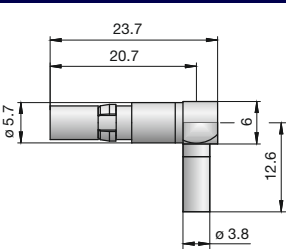
Ordering Number	Cable Group	Assembly Instruction	Crimp Inserts	Packing Unit	
745 S 201-302 L5	02	55 B	11 W 150-102	100	

Straight Jack, solder-crimp

Flexible Cables

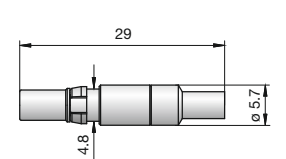
Ordering Number	Cable Group	Assembly Instruction	Crimp Inserts	Packing Unit	
745 K 101-302 L5	02	55 A	11 W 150-102	100	

Right Angle Jack, solder-crimp

Flexible Cables

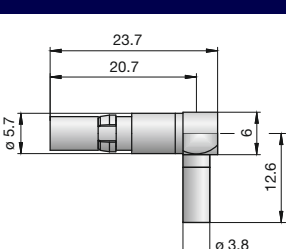
Ordering Number	Cable Group	Assembly Instruction	Crimp Inserts	Packing Unit	
745 K 201-302 L5	02	55 B	11 W 150-102	100	

### PCB Connectors - Solder Pin

Straight Plug, PCB

Solder Pin

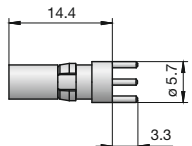
Ordering Number	Remarks	Panel Piercing / PCB Layout	Packing Unit	
745 S 101-400 L5	round pins	B 39	100 blister	

Right Angle Plug, PCB

Solder Pin

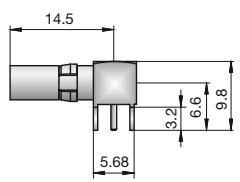
Ordering Number	Panel Piercing / PCB Layout	Packing Unit	
745 S 201-400 L5	B 30c	100 blister	

Right Angle Jack, PCB

Solder Pin

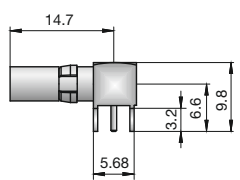
Ordering Number	Panel Piercing / PCB Layout	Packing Unit	
745 K 201-400 L5	B 30c	100 blister	

### Adaptors

Adaptors (In Series)

Ordering Number	Version	Remarks	Packing Unit	
745 K 101-K00 L5	straight	0.8-2.7 female - female	1	

## Interface Dimensions Inserts High Voltage DIN 41626-T2

Code 25

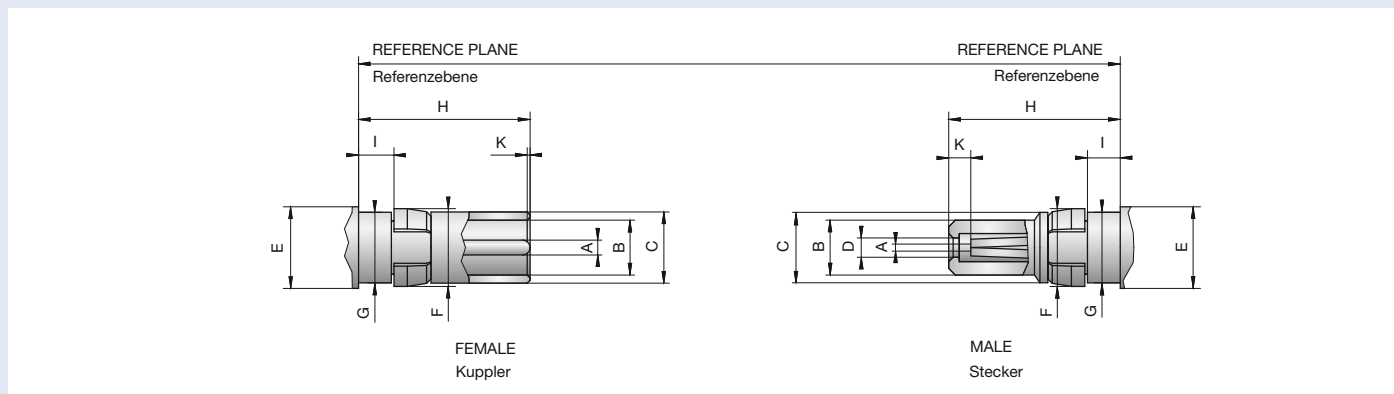

## Inserts High Voltage DIN 41626-T2

dimension [mm]	Female   Kuppler		Male   Stecker	
	min.	max.	min.	max.
A	0.99	1.04		1)
B	3.69	3.75	3.55	3.65
C	4.70	4.80	4.70	4.80
D			1.25	1.35
E		5.50		5.50
F		5.25		5.25
G	4.74	4.79	4.74	4.79
H	11.50	11.70	11.50	11.70
I	2.22	2.40	2.22	2.40
K	-0.25	0.25	1.10	1.70

1) resilient, dimension to meet electrical and mechanical requirements

High Voltage Inserts are designed for use in mixed card edge connections in accordance to DIN 41612. Small dimensions enable high packing densities, the contacts are installed by snap-in method. A combination with coaxial connectors, high current and high voltage connectors is possible.

### Please note - reverse polarity design

Male connectors are equipped with female center contacts, female connectors with male center contacts.

*Hochspannungs-Einsätze sind für den Einsatz in Mischleisten nach DIN 41612 ausgelegt, die geringe Baugröße ermöglicht hohe Packungsdichten. Die Montage in Leisten erfolgt durch Einrasten, eine Kombination mit Koaxial-Steckverbindern, Hochstrom- und Hochspannungs-Steckverbindern ist möglich.*

### Achtung - Reverse Polarity-Ausführung:

*Die Stecker sind mit einem Buchsen-Innenleiter, die Kuppler mit einem Stift-Innenleiter ausgestattet.*

## Features

Interface according to DIN 41626-T2  
Working voltage 2800 V rms  
Plug-in/Snap-in DIN 41612 chassis  
Inverse center contact

## Product Range

High voltage inserts

Further connectors are available on request

## Technical Data Inserts High Voltage DIN 41626-T2

Code 25

<b>Applicable standards   Anwendbare Normen</b>	
Interface according to   <i>Interface gemäß</i>	DIN 41626-T2
Quality tested according to   <i>Qualitätsprüfung gemäß</i>	IEC 60068
<b>Electrical data   Elektrische Daten</b>	
Contact resistance   <i>Übergangswiderstand</i>	≤ 3 mΩ
Test voltage   <i>Prüfspannung</i>	3800 V rms
Working voltage   <i>Betriebsspannung</i>	2800 V rms
Contact current   <i>Kontaktstrombelastbarkeit</i>	≤ 1.5 A
<b>Mechanical data   Mechanische Daten</b>	
Mating cycles   <i>Steckzyklen</i>	≥ 100
<b>Environmental data   Umweltdaten</b>	
Temperature range   <i>Temperaturbereich</i>	-55 °C to +125 °C
Dry heat   <i>Trockene Wärme</i>	IEC 60068-2-2
Damp heat   <i>Feuchte Wärme</i>	IEC 60068-2-78
Climatic category   <i>Klimakategorie</i>	IEC 60068-2-1 55/125/21
<b>Materials   Materialien</b>	
Spring loaded contact parts   <i>Federnde Kontaktteile</i>	CuBe, Au plating
Center contact   <i>Innenleiter</i>	CuZn, Au plating
Clip   <i>Clip</i>	CuBe, Ni plating
Dielectric   <i>Dielektrikum</i>	PTFE

Rosenberger-connectors fulfill in principle the indicated data of the Technical Data. Individual values of connectors may deviate depending upon application, design, type of cable, assembly method and execution. Specific data sheets for particular products can be provided on request from your Rosenberger sales partner.

*Rosenberger-Steckverbinder erfüllen grundsätzlich die in den Technischen Daten angegebenen Daten. Je nach Anwendung, Bauart, Kabeltyp, Montageart und -ausführung können einzelne Werte von Steckverbindern hiervon abweichen. Spezifische Datenblätter zu einzelnen Produkten erhalten Sie auf Anfrage von Ihrem Rosenberger-Ansprechpartner.*

## Cable Connectors

Straight Plug, solder

Ordering Number	Remarks	Cable Size	Packing Unit	
25 S 101-200	colour: red	AWG 20	100	

Right Angle Plug, solder

Ordering Number	Remarks	Cable Size	Packing Unit	
25 S 201-200	colour: red	AWG 20	100	

Straight Jack, solder

Ordering Number	Remarks	Cable Size	Packing Unit	
25 K 101-200	colour: blue	AWG 20	100	

Right Angle Jack, solder

Ordering Number	Remarks	Cable Size	Packing Unit	
25 K 201-200	colour: blue	AWG 20	100	



## Interface Dimensions Inserts Power DIN 41626-T1 / D-Sub

Code 50

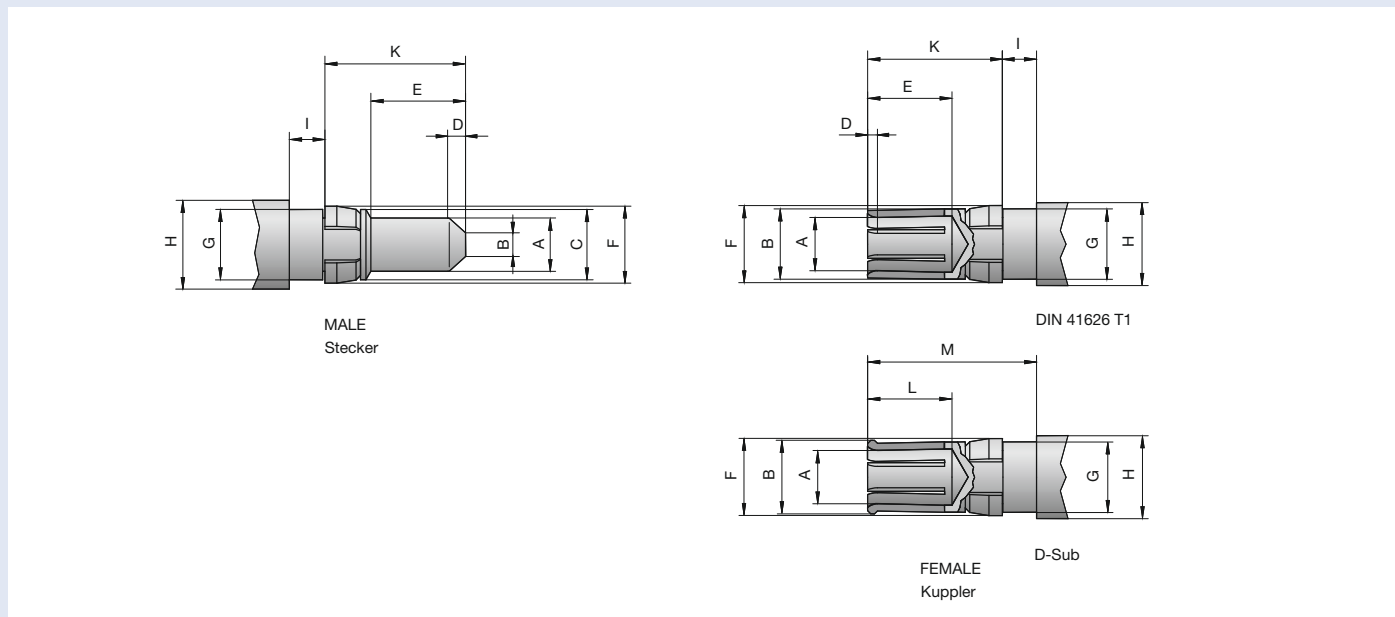

## Inserts Power DIN 41626-T1 / D-Sub

dimension [mm]	Male   Stecker		Female   Kuppler	
	min.	max.	min.	max.
A	3.55	3.60		1)
B	1.00	1.60		4.75
C		4.76		
D	0.90	1.10	0.40	0.50
E	6.40	6.50	5.70	5.85
F		5.25		5.25
G	4.76	4.79	4.76	4.79
H		6.00 2)		6.00 2)
I	2.22	2.40	2.22	2.40
K	9.50	9.65	9.00	9.15
L				6.50
M			11.75	11.90

1) resilient, dimension to meet electrical and mechanical requirements

2) square shape optional

High Power Inserts meet the requirements of DIN 41626-T1 and are designed for use in mixed card edge connections in accordance to DIN 41612 or D-Sub. The contacts are installed by snap-in method, a combination with coaxial connectors, high current and high voltage connectors is possible.

*Hochstrom-Einsätze entsprechen der Norm DIN 41626-T1 und sind für Anwendungen in Mischleisten nach DIN 41612 oder D-Sub ausgelegt. Die Montage der Kontakte erfolgt durch Einrasten, eine Kombination mit Koaxial-Steckverbindern, Hochstrom- und Hochspannungs-Steckverbindern ist möglich.*

### Features

Interface according to DIN 41626-T1 / D-Sub  
 Contact current 10 A, 20 A, 30 A, 40 A  
 Plug-in/Snap-in DIN 41612 chassis

### Product Range

Power inserts (10 A, 20 A, 30 A, 40 A)  
 PCB connectors (solder versions)  
 Adaptors

Further connectors are available on request

**Technical Data Inserts Power DIN 41626-T1 / D-Sub Code 50**

<b>Applicable standards   Anwendbare Normen</b>	
Interface according to   <i>Interface gemäß</i>	DIN 41626-T1, D-Sub
Quality tested according to   <i>Qualitätsprüfung gemäß</i>	IEC 60068
<b>Electrical data   Elektrische Daten</b>	
Contact resistance   <i>Übergangswiderstand</i>	≤ 1mΩ
Contact current   <i>Kontaktstrombelastbarkeit</i>	10 A, 20 A, 30 A, 40 A
<b>Mechanical data   Mechanische Daten</b>	
Mating cycles   <i>Steckzyklen</i>	≥ 500
Connector captivation in plastic   <i>Haltekraft des Steckverbinders in Kunststoff</i>	≥ 52 N
Engagement force   <i>Steckkraft</i>	≤ 10 N
Disengagement force   <i>Ziehkraft</i>	≥ 1.6 N
<b>Environmental data   Umweltdaten</b>	
Temperature range   <i>Temperaturbereich</i>	-55 °C to +125 °C
Dry heat   <i>Trockene Wärme</i>	IEC 60068-2-2
Damp heat   <i>Feuchte Wärme</i>	IEC 60068-2-78
Climatic category   <i>Klimakategorie</i>	IEC 60068-2-1 55/125/21
Max. soldering temperature (PCB connectors)   <i>Max. Löttemperatur (Leiterplattensteckverbinder)</i>	IEC 61760-1, +260 °C for 10 sec.
<b>Materials   Materialien</b>	
Spring loaded contact parts   <i>Federnde Kontaktteile</i>	CuBe / CuSn, Au plating
Center contact   <i>Innenleiter</i>	CuZn, Au plating
Clip   <i>Clip</i>	CuBe, Ni plating

Rosenberger-connectors fulfill in principle the indicated data of the Technical Data. Individual values of connectors may deviate depending upon application, design, type of cable, assembly method and execution. Specific data sheets for particular products can be provided on request from your Rosenberger sales partner.

*Rosenberger-Steckverbinder erfüllen grundsätzlich die in den Technischen Daten angegebenen Daten. Je nach Anwendung, Bauart, Kabeltyp, Montageart und -ausführung können einzelne Werte von Steckverbindern hiervon abweichen. Spezifische Datenblätter zu einzelnen Produkten erhalten Sie auf Anfrage von Ihrem Rosenberger-Ansprechpartner.*

**Connectors - for D-Sub and DIN 41612**

Straight Plug, solder

for D-Sub and DIN 41612

Ordering Number	Remarks	Power	Packing Unit
50 S 101-240 L	a = 4.8 mm; b = 5.6 mm; c = 5.2 mm	40 A	100

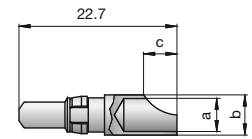

Straight Plug, crimp

for D-Sub and DIN 41612

Ordering Number	Remarks	Power	Assembly Instruction	Packing Unit
50 S 101-110 L	a = 1.7 mm; b = 2.55 mm	10 A	50 A	100
50 S 101-120 L	a = 2.8 mm; b = 3.7 mm	20 A	50 A	100
50 S 101-130 L	a = 3.5 mm; b = 4.4 mm	30 A	50 A	100
50 S 101-140 L	a = 4.8 mm; b = 5.6 mm	40 A	50 A	100

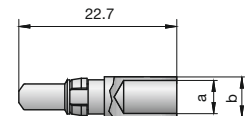

**Connectors - for D-Sub**

Straight Jack, solder

for D-Sub shells only

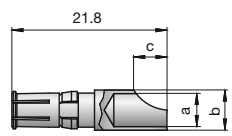
Ordering Number	Remarks	Power	Packing Unit	
50 K 101-230 L	a = 3.5 mm; b = 4.4 mm; c = 5.2 mm	30 A	100	

Straight Jack, crimp

for D-Sub shells only

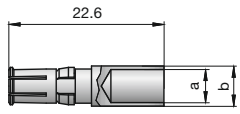
Ordering Number	Remarks	Power	Assembly Instruction	Packing Unit	
50 K 101-110 L	a = 1.7 mm; b = 2.55 mm	10 A	50 A	100	
50 K 101-120 L	a = 2.8 mm; b = 3.7 mm	20 A	50 A	100	
50 K 101-130 L	a = 3.5 mm; b = 4.4 mm	30 A	50 A	100	
50 K 101-140 L	a = 4.4 mm; b = 5.6 mm	40 A	50 A	100	

**Connectors - for DIN 41612**

Straight Jack, crimp

for DIN 41612 shells only

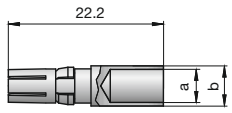
Ordering Number	Remarks	Power	Assembly Instruction	Packing Unit	
50 K 102-110 L	a = 1.7 mm; b = 2.55 mm	10 A	50 A	100	
50 K 102-120 L	a = 2.8 mm; b = 3.7 mm	20 A	50 A	100	
50 K 102-130 L	a = 3.5 mm; b = 4.4 mm	30 A	50 A	100	
50 K 102-140 L	a = 4.8 mm; b = 5.6 mm	40 A	50 A	100	

## PCB Connectors - for D-Sub and DIN 41612

Right Angle Plug, PCB

for D-Sub and DIN 41612

Ordering Number	Power	Panel Piercing / PCB Layout	Packing Unit	
50 S 201-440 L	40 A	B 30c	100 blister	

Right Angle Plug, PCB, solder pin long version

for D-Sub and DIN 41612

Ordering Number	Power	Panel Piercing / PCB Layout	Packing Unit	
50 S 222-410 L	10 A	1.0 mm	100	

## PCB Connectors - for DIN 41612 shells only

Straight Jack, PCB

for DIN 41612 shells only

Ordering Number	Power	Packing Unit	
50 K 102-540 L	40 A	100	

Straight Jack PCB, press fit

for DIN 41612 shells only

Ordering Number	Power	Packing Unit	
50 K 112-930 L	30 A	100	

Right Angle Jack, PCB

for DIN 41612 shells only

Ordering Number	Power	Panel Piercing / PCB Layout	Packing Unit	
50 K 202-440 L	40 A	B 30c	100 blister	

**Adaptors**

Adaptors (In Series)

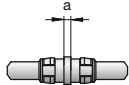
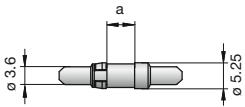
Ordering Number	Version	Remarks	Packing Unit	
50 S 101-S00 L	straight	Power male - male, for D-Sub and DIN 41612, a = 1.3 mm	100	
50 S 105-S00 L	straight	Power male - male, for D-Sub and DIN 41612, a = 6.7 mm	100	
50 S 104-S00 L	straight	Power male - male, for D-Sub and DIN 41612, a = 7.5 mm	100	
50 S 108-S00 L	straight	Power male - male, for D-Sub and DIN 41612, a = 8.3 mm	100	