

2478- * * * - * * *

MATERIAL CODE
 (.27)/.0106 THK
 1=BRASS
 3=PHOS BRONZE

OPTION CODE
 BLANK=AS SHOWN
 C=CAT EAR OPTION

WINDING SPEC.
 A=PER ES-339-A
 BLANK=PER ES-339-B
 L=LOOSE

FINISH:

(P909) OVERALL HOT TIN DIP: (0.00254)/.000100 MIN.
 (122) OVERALL TIN: (0.00381)/.000150 MIN.
 OVER (0.00076)/.000030 MIN. NICKEL
 (154) OVERALL TIN: (0.00254)/.000100 MIN.
 OVER (0.00127)/.000050 MIN. NICKEL
 (224) OVERALL MATTE TIN: (0.00508)/.000200 MIN.
 OVER (0.00127)/.000050 MIN. NICKEL
 (550) SELECT GOLD: (0.00038)/.000015 MIN.
 OVERALL GOLD FLASH: (0.00005)/.000002 MIN.
 OVERALL NICKEL UNDERPLATE: (0.00076)/.000030 MIN.
 (555) SELECT GOLD: (0.00038)/.000015 MIN.
 OVERALL NICKEL UNDERPLATE: (0.00076)/.000030 MIN.
 (558) SELECT GOLD: (0.00076)/.000030 MIN.
 OVERALL GOLD FLASH: (0.00005)/.000002 MIN.
 OVERALL NICKEL UNDERPLATE: (0.00127)/.000050 MIN.
 (561) SELECT GOLD: (0.00076)/.000030 MIN.
 OVERALL NICKEL UNDERPLATE: (0.00127)/.000050 MIN.
 (591) SELECT GOLD: (0.00127)/.000050 MIN.
 OVERALL GOLD FLASH: (0.00005)/.000002 MIN.
 OVERALL NICKEL UNDERPLATE: (0.00127)/.000050 MIN.

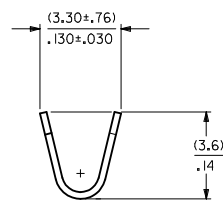
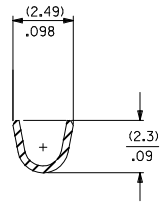
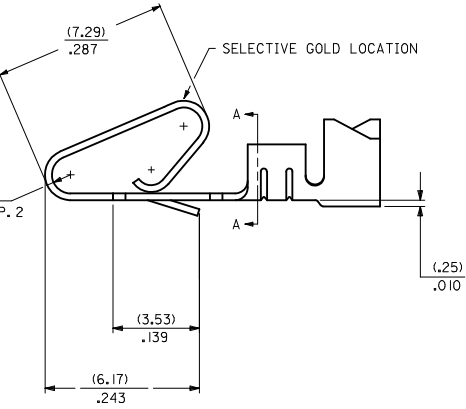
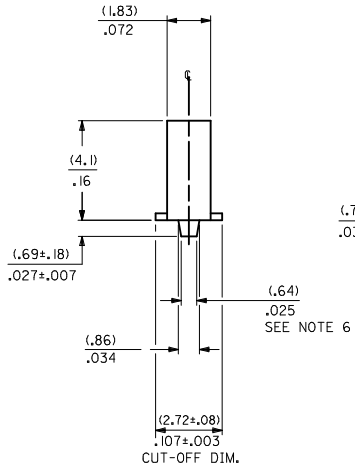

- NOTES:
1. MATERIAL: SEE LEGEND
 2. FINISH: SEE LEGEND
 3. THIS PART CONFORMS TO PRODUCT SPECIFICATION PS-08-50.
 4. PACKAGING SPECIFICATION: LOOSE TERMINALS: PER PK-2759-001
CHAIN FORM TERMINALS: NONE
 5. DIMENSIONS GIVEN ACROSS CENTERLINES ARE SYMMETRICAL ABOUT THOSE CENTERLINES WITHIN HALF THE TOTAL TOLERANCE.
 6. (0.86 ±0.05)/.034 ±.002 IS AN OPTIONAL DESIGN.
 7. CRIMP ACCEPTS 18 TO 24 AWG WIRE WITH (2.79)/.110 MAX. INSULATION DIAMETER. AND CAN ACCEPT (3.00)/.118 MAX. INSULATION DIAMETER WITH SPECIAL TOOLING.
 8. TERMINAL FOR USE IN 2139, 3001, 3069, AND 91813 SERIES HOUSINGS WITH (2.54)/.100 MAX. INSULATION DIAMETER, 2574, 6422, AND 5239 SERIES HOUSINGS WITH (2.79)/.110 MAX. INSULATION DIAMETER, AND 41695 SERIES HOUSING WITH (3.00)/.118 MAX. INSULATION DIAMETER.
 9. THIS PART CONFORMS TO CLASS B REQUIREMENTS OF COSMETIC SPECIFICATION PS-45499-002.

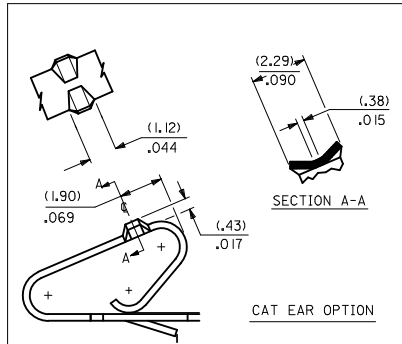
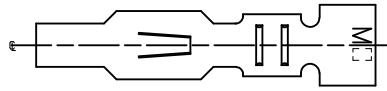

REMOVE 208 PLTING EC NO. UCP2012-2810 DRAWN: JAGUILAR 2012/02/27 CHYKHAI KIPPER 2012/02/27 APPROV: FSMITH 2012/03/20	QUALITY SYMBOLS	GENERAL TOLERANCES (UNLESS SPECIFIED)	DIMENSION STYLE	SCALE	DESIGN UNITS	THIRD ANGLE PROJECTION	
	∇=0 ∇=0 ∇=0	mm INCH 4 PLACES ±.010 ±.010 3 PLACES ±.025 ±.014 2 PLACES ±.036 ±.014 1 PLACE ±.036 ±.014 ANGULAR ±1/2°	MM/IN	10:1	INCH	DRAWN BY: SAMIEC DATE: 06/03/86 CHECKED BY: PATEL DATE: 06/03/86 APPROVED BY: FSMITH DATE: 2012/03/20	TITLE: CRIMP TERMINAL .156 CENTERS 18 TO 24 GA WIRE MOLEX INCORPORATED DOCUMENT NO. SD-2478
	DRAFT WHERE APPLICABLE MUST REMAIN WITHIN DIMENSIONS	SEE CHART	SIZE D	THIS DRAWING CONTAINS INFORMATION THAT IS PROPRIETARY TO MOLEX INCORPORATED AND SHOULD NOT BE USED WITHOUT WRITTEN PERMISSION			
						SHEET NO. 1 OF 2	

20 19 18 17 16 15 14 13 12 11 10 9 8 7 6 5 4 3 2 1

2478-1-(***)*

PART NO.	ENG. NO.
08-50-0105	2478-1-(P909)
08-50-0106	2478-1-(P909)L
08-56-0105	2478-1-(550)
08-56-0106	2478-1-(550)L
08-55-0103	2478-1-(555)
08-55-0104	2478-1-(555)L
08-50-0119	2478-1-(122)
08-50-0120	2478-1-(122)L
08-50-0271	2478-1-(P909)A
08-50-0015	2478-1-(154)
08-50-0016	2478-1-(154)L
08-50-0063	2478-1-(224)
08-50-0064	2478-1-(224)L
08-55-0133	2478-1-(561)
08-55-0134	2478-1-(561)L

2478-3-(***)*

PART NO.	ENG. NO.
08-52-0071	2478-3-(P909)
08-52-0072	2478-3-(P909)L
08-65-0114	2478-3-(555)
08-65-0115	2478-3-(555)L
08-52-0811	2478-3-(154)
08-52-0812	2478-3-(154)L
08-50-0281	2478-3-(122)
	2478-3-(122)L
08-58-0121	2478-3-(550)
08-58-0122	2478-3-(550)L
08-58-0103	2478-3-(591)
08-58-0104	2478-3-(591)L
08-58-0114	2478-3-(558)
08-58-0115	2478-3-(558)L

2478-1C-(***)*

PART NO.	ENG. NO.
08-50-0091	2478-1C-(154)
08-50-0093	2478-1C-(154)L

2478-3C-(***)*

PART NO	ENG NO
08-52-0044	2478-3C-(P909)
08-52-0045	2478-3C-(P909)L
08-52-0023	2478-3C-(154)
08-52-0024	2478-3C-(154)L

REMOVE 208 PLTG IEC NO: UCF2012-2810 DRAWN: JAGUILAR 2012/02/27 CHECKED: KIPPER 2012/02/27 APPR: FSMITH 2012/03/20	QUALITY SYMBOLS	GENERAL TOLERANCES (UNLESS SPECIFIED)	DIMENSION STYLE	SCALE	DESIGN UNITS	THIRD ANGLE PROJECTION	
	▽=0	mm INCH	MM/IN	1:1	INCH		
	▽=0	4 PLACES ± --- ± --- 3 PLACES ± --- ± .010 2 PLACES ± 0.25 ± .014 1 PLACE ± 0.36 ± ---	DRAWN BY DATE SAMI EC 06/03/86	TITLE CRIMP TERMINAL .156 CENTERS 18 TO 24 GA WIRE			
	▽=0	ANGULAR ±1/2°	CHECKED BY DATE PATEL 06/03/86	MATERIAL NO. SD-2478			
	DRAFT WHERE APPLICABLE MUST REMAIN WITHIN DIMENSIONS	APPROVED BY DATE FSMITH 2012/03/20	SEE CHART		MOLEX INCORPORATED		
			SIZE D		SHEET NO. 2 OF 2		
			THIS DRAWING CONTAINS INFORMATION THAT IS PROPRIETARY TO MOLEX INCORPORATED AND SHOULD NOT BE USED WITHOUT WRITTEN PERMISSION				