

73 CKT
SCALE 3:2

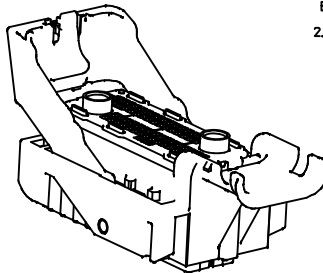

66 CKT
SCALE 3:2

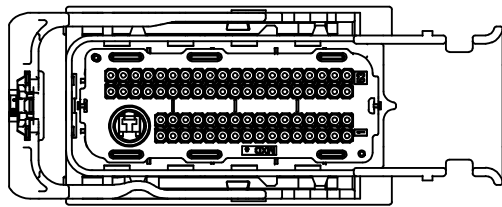
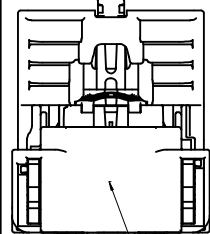

(47.92)

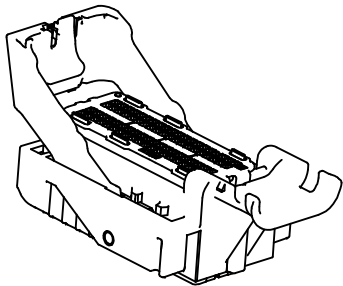
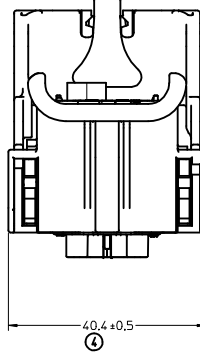
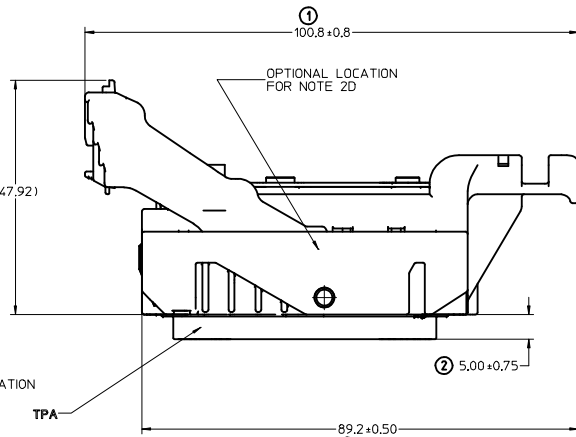

80 CKT
SCALE 3:2

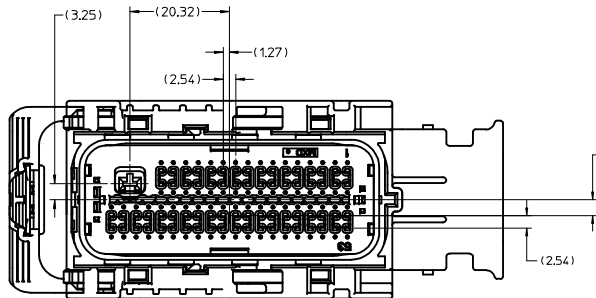

NOTES: UNLESS OTHERWISE SPECIFIED

1. MATERIAL:

- A. RESIN: SEE COMPONENT DRAWINGS
- B. COLOR: SEE TABLE

2. DESIGN - GENERAL:

- A. THIS IS A 100% CAD GENERATED PART. THE CAD MATHEMATICAL DATA IS THE MASTER FOR THIS PART. FOR DIMENSIONAL OR ANY INFORMATION NOT SHOWN ON THIS DRAWING, ANALYZE THE CAD MODEL.
- B. TOLERANCES:
 - a. LINEAR XX ± 0.30
 - XXX ± 0.10
 - XXX ± 0.10
 - b. ANGULAR X° ± 3.0°
- C. CORNERS SHOWN AS SHARP TO BE R 0.2 MAX.
- D. FOLLOWING PRODUCTION CODES TO BE PERMANENTLY MARKED & HUMAN READABLE TO A LETTER HEIGHT < 3mm.
 - LINE #1: MATERIAL #: XXXX-XXXX
 - LINE #2: DATE CODE: JJJ (JULIAN DAY, LAST DIGIT OF YEAR)
 - LINE #3: INSPECTION MACHINE CODE + SERIAL #:X_XXXXX
- E-1. PARTS MUST BE FREE OF DISCOLORATION, SALT RESIDUE AND OTHER IMPERFECTIONS THAT AFFECT FIT OR FUNCTION.
- E-2. SCRATCHES OR DENTS NOT TO EXCEED 0.13mm IN DEPTH.
- F. CHANGES IN DESIGN FROM PART PREVIOUSLY APPROVED REQUIRES PRIOR ENGINEERING APPROVAL. THIS INCLUDES BUT IS NOT LIMITED TO DRAFT, MATERIAL OR PROCESSING.
- G. SHALL CONFORM TO THE FOLLOWING PACKAGING SPECIFICATION: PK-31300-019

3. DESIGN - MANUFACTURING:

- A. DRAFT TO BE WITHIN TOLERANCE.
- B. ALLOWABLE FLASH 0.2 MAX HIGH X 0.13 MAX THICK.
- C. ALLOWABLE PARTING LINE MISMATCH 0.2 MAX.
- D. EJECTOR PINS MARK TO BE FLUSH TO 0.25 MAX DEPRESSED.
- E. ALLOWABLE GATE VESTIGE TO BE FLUSH TO 0.25 MAX PROTRUSION.

4. SYSTEM REQUIREMENTS:

- WHEN TESTED TO SAE/USCAR-2 REV: 3, APRIL 2001, AND GMW #3191, AUGUST 22, 2000 (DRAFT).
- A. TPA (WITHOUT TERMINALS)
 - a. INSERTION FORCE FROM PRE-SET TO LOCK: ≥20
 - b. REMOVAL FORCE FROM PRE-SET: ≥20
 - B. CPA
 - a. INSERTION FORCE FROM PRE-SET TO LOCK WITH CONNECTOR UN-MATED: ≥60N
 - b. REMOVAL FORCE FROM PRE-SET: ≥30N
 - C. GROMMET CAP
 - a. REMOVAL FORCE FROM HOUSING WITH ENGAGED LATCHES: ≥110N
 - D. MATE ASSIST LEVER
 - a. INADVERTENT ACTUATION FORCE DURING SHIPPING, HANDLING OR PRE-ASSEMBLY: ≥190N

REV	DESCRIPTION	THIRD ANGLE PROJECTION
G5	ADDED PART NUMBERS 34566-6173 34566-6183 34566-6193	MX123 66/73/80CKT HRNS CONN ASSY molex SD-34566-001 SHEET NO. 1 OF 68
G4	ADDED PART NUMBERS 34566-6093 34566-6110 34566-6123 34566-6133	
G3	ADDED PART NUMBERS 34566-6083	
G2	ADDED PART NUMBERS 34566-6053 34566-6063 34566-6073	
G1	ADDED PART NUMBERS 34566-6023 34566-6033 34566-6043	
G	ADDED PART NUMBERS 34566-5923 34566-6013	
F99	ADDED PART NUMBERS 34566-5983	
F98	ADDED PART NUMBERS 34566-5943 34566-5953 34566-5963 34566-5973	
F97	ADDED PART NUMBERS 34566-5933	
F96	ADDED PART NUMBERS 34566-5863 34566-5873 34566-5883 34566-5893 34566-5913	
F95	ADDED PART NUMBERS 34566-5853	
F94	ADDED PART NUMBERS 34566-5843	
F93	ADDED PART NUMBERS 34566-5733 34566-5743 34566-5753 34566-5763 34566-5773 34566-5783 34566-5793 34566-5813 34566-5823 34566-5833	
F92	ADDED PART NUMBERS 34566-5313 34566-5433 34566-5443 34566-5453 34566-5463 34566-5473 34566-5483 34566-5493 34566-5513 34566-5523 34566-5533 34566-5543 34566-5553 34566-5563 34566-5573 34566-5583 34566-5593 34566-5613 34566-5623 34566-5633 34566-5643 34566-5653 34566-5663 34566-5673 34566-5683 34566-5693 34566-5713	
F91	ADDED PART NUMBERS 34566-5353 34566-5363 34566-5373 34566-5383 34566-5393 34566-5413	
F90	ADDED PART NUMBERS 34566-5343	
F89	ADDED PART NUMBERS 34566-5223 34566-5333	
F88	ADDED PART NUMBERS 34566-5283 34566-5293	
F87	ADDED PART NUMBERS 34566-5263 34566-5273	
F86	ADDED PART NUMBERS 34566-5243 34566-5253	
F85	ADDED PART NUMBERS 34566-5193 34566-5213 34566-5223 34566-5233	
F84	ADDED PART NUMBERS 34566-5183	
F83	ADDED PART NUMBERS 34566-5163 34566-5173	
F82	ADDED PART NUMBERS 34566-5063 34566-5073 34566-5083 34566-5093 34566-5113 34566-5123 34566-5133 34566-5143 34566-5153	
F81	ADDED PART NUMBERS 34566-5023 34566-5033 34566-5043 34566-5053	

ENTER DESCRIPTION IEC NO: UAU2014-0376 DRAWN BY: SKRA JENDRANA CHKD: MVANS LAMBROU APPR: IKOSHY DATE: 2013/09/06 REV: G5	QUALITY SYMBOLS ∇=0 ∇=0 ∇=0	GENERAL TOLERANCES (UNLESS SPECIFIED): 4 PLACES ± --- + --- 3 PLACES ± --- + --- 2 PLACES ± --- + --- 1 PLACE ± --- + --- 0 PLACE ± --- + --- ANGULAR ± --- ° DRAFT WHERE APPLICABLE MUST REMAIN WITHIN DIMENSIONS	DIMENSION STYLE MM ONLY	SCALE 2:1	DESIGN UNITS METRIC	TITLE MX123 66/73/80CKT HRNS CONN ASSY molex SD-34566-001	SHEET NO. 1 OF 68

80 CKT

WIRE DRESS OPTION 0

HOUSING ONLY, SHOWN FOR CLARITY

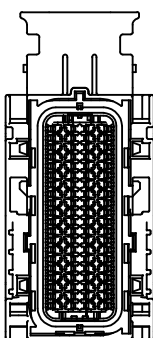
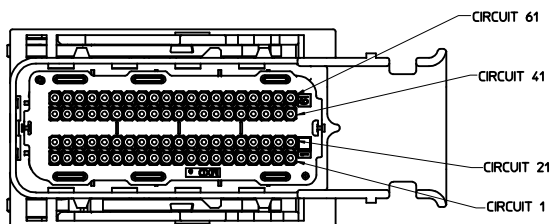

KEY G

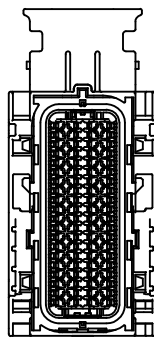

KEY H

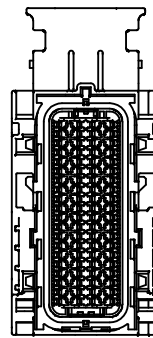

KEY J

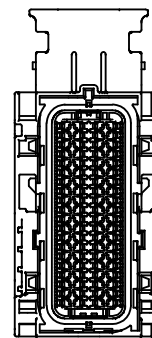

KEY K

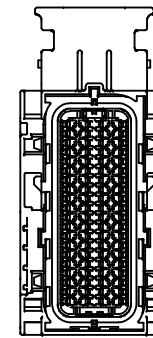

KEY L

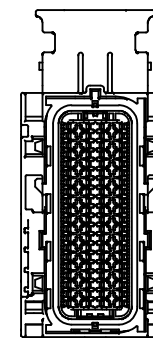

KEY M

WIRE DRESS OPTION 9

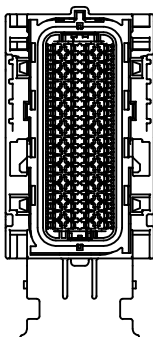
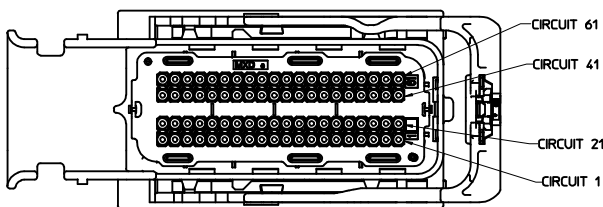

KEY G

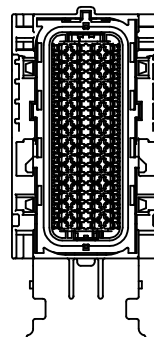

KEY H

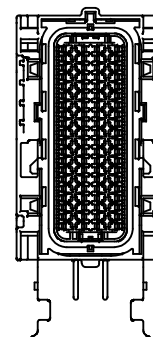

KEY J

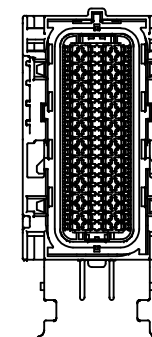

KEY K

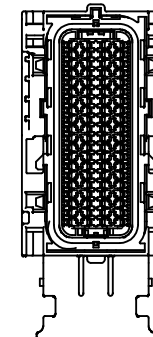

KEY L

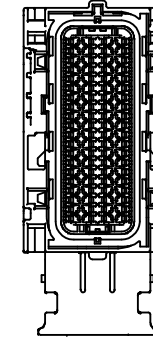

KEY M

ENTER DESCRIPTION EC NO: UAU2014-0376 DRAWN BY: CHYD APPR: WOSHY REV: G5	2013/09/05 DESCRIPTION	QUALITY SYMBOLS ▽=0 ▽=0 ▽=0	GENERAL TOLERANCES (UNLESS SPECIFIED) mm INCH 4 PLACES +--- +--- 3 PLACES +--- +--- 2 PLACES +--- +--- 1 PLACE +--- +--- 0 PLACE +--- +---	DIMENSION STYLE MM ONLY	SCALE 1.5:1	DESIGN UNITS METRIC	THIRD ANGLE PROJECTION
	DRAWN BY: SKRAJENDRANA DATE: 2011/02/14	CHECKED BY: MVANSLAMBROU DATE: 2011/02/14	APPROVED BY:	MATERIAL NO.	DOCUMENT NO.	TITLE MX123 66/73/80CKT HRNS CONN ASSY	SHEET NO. 2 OF 68
	SEE BOM TABLE	SD-34566-001	molex	THIS DRAWING CONTAINS INFORMATION THAT IS PROPRIETARY TO MOLEX INCORPORATED AND SHOULD NOT BE USED WITHOUT WRITTEN PERMISSION			
	DRAFT WHERE APPLICABLE MUST REMAIN WITHIN DIMENSIONS						

73 CKT

WIRE DRESS OPTION 0

HOUSING ONLY, SHOWN FOR CLARITY

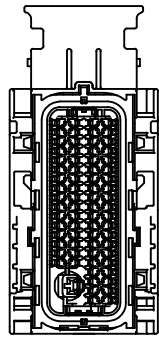
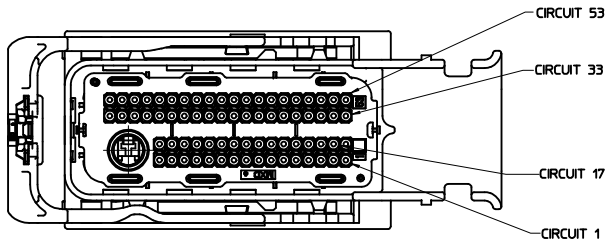

KEY A

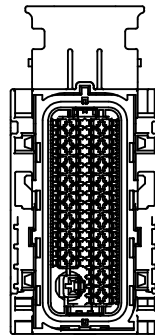

KEY B

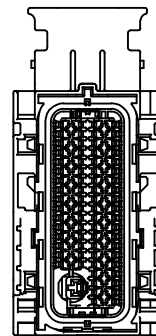

KEY C

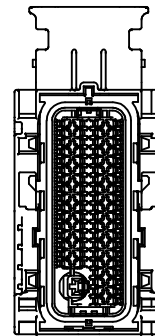

KEY D

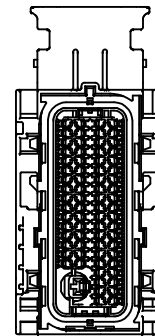

KEY E

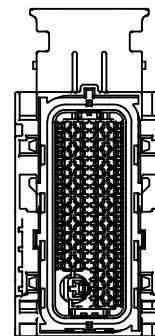

KEY F

WIRE DRESS OPTION 9

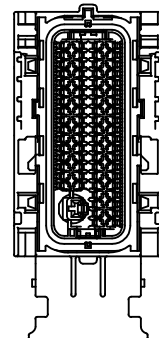
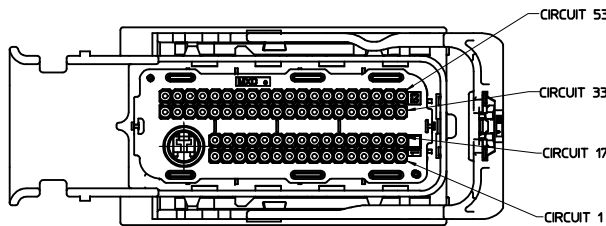

KEY A

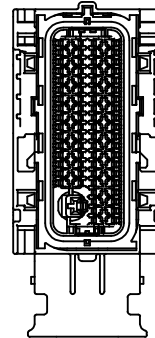

KEY B

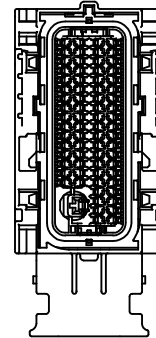

KEY C

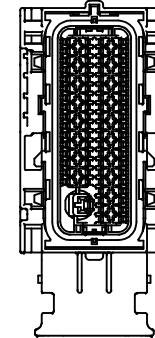

KEY D

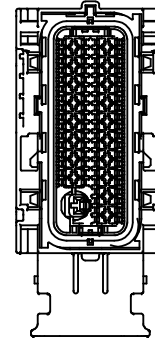

KEY E

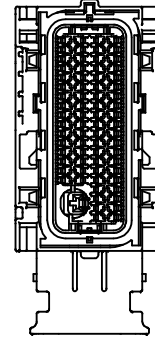

KEY F

ENTER DESCRIPTION IEC NO: UAU2014-0376 DRAWN BY: CHYK CHKD: APPR:VKOSHY 2013/09/05 2013/09/06	QUALITY SYMBOLS	GENERAL TOLERANCES (UNLESS SPECIFIED)		DIMENSION STYLE	SCALE	DESIGN UNITS	THIRD ANGLE PROJECTION
	▽=0	mm	INCH	MM ONLY	1.5:1	METRIC	
	▽=0	4 PLACES	+	SKRAJENDRANA 2011/02/14	DATE	TITLE	
	▽=0	3 PLACES	+	MYANSLAMBROU 2011/02/14	DATE		
▽=0	2 PLACES	+		DATE			
	1 PLACE	+		DATE			
	0 PLACE	+		DATE			
	ANGULAR ±	DRAFT WHERE APPLICABLE MUST REMAIN WITHIN DIMENSIONS		MATERIAL NO.	DOCUMENT NO.		
				SEE BOM TABLE	SD-34566-001		
				THIS DRAWING CONTAINS INFORMATION THAT IS PROPRIETARY TO MOLEX INCORPORATED AND SHOULD NOT BE USED WITHOUT WRITTEN PERMISSION			

MX123
66/73/80CKT
HRNS CONN ASSY

molex

SHEET NO.
3 OF 68

66 CKT

WIRE DRESS OPTION 0

HOUSING ONLY, SHOWN FOR CLARITY

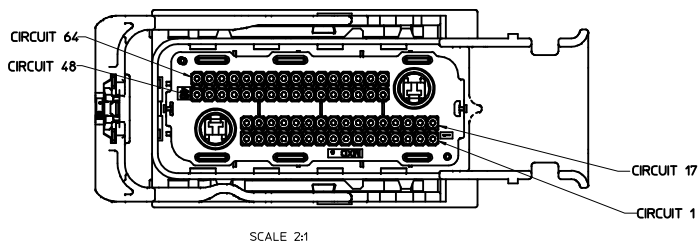

SCALE 2:1

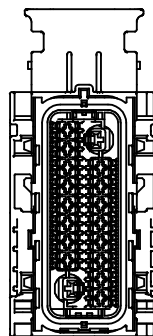

KEY A

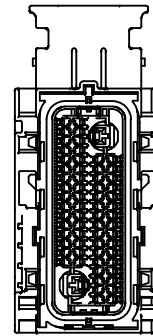

KEY C

WIRE DRESS OPTION 9

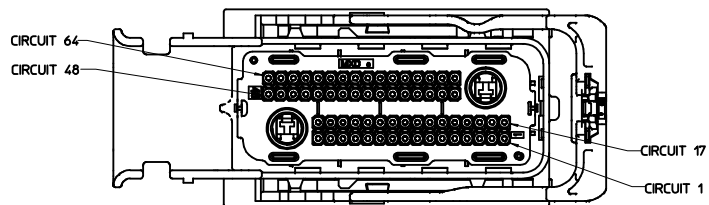

SCALE 2:1

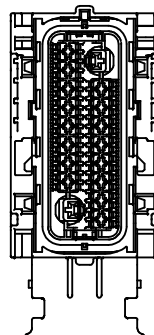

KEY A

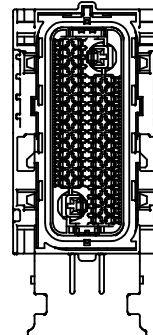

KEY C

ENTER DESCRIPTION DEC NO: UAU2014-0376 DRAWN BY CHYD: APPR: WOSHY 2013/09/05 2013/09/06 65 REV	QUALITY SYMBOLS ▽=0 ▽=0 ▽=0	GENERAL TOLERANCES (UNLESS SPECIFIED) <table border="1"> <thead> <tr> <th></th> <th>mm</th> <th>INCH</th> </tr> </thead> <tbody> <tr> <td>4 PLACES</td> <td>±----</td> <td>+---</td> </tr> <tr> <td>3 PLACES</td> <td>±----</td> <td>±---</td> </tr> <tr> <td>2 PLACES</td> <td>±----</td> <td>±---</td> </tr> <tr> <td>1 PLACE</td> <td>±----</td> <td>±---</td> </tr> <tr> <td>0 PLACE</td> <td>±----</td> <td>±---</td> </tr> </tbody> </table> ANGULAR ±----- DRAFT WHERE APPLICABLE MUST REMAIN WITHIN DIMENSIONS		mm	INCH	4 PLACES	±----	+---	3 PLACES	±----	±---	2 PLACES	±----	±---	1 PLACE	±----	±---	0 PLACE	±----	±---	DIMENSION STYLE MM ONLY DRAWN BY SKRAJENDRANA DATE 2011/02/14 CHECKED BY DATE MYANSLAMBROU 2011/02/14 APPROVED BY DATE	SCALE 1.5:1 DESIGN UNITS METRIC THIRD ANGLE PROJECTION	TITLE MX123 66/73/80CKT HRNS CONN ASSY molex	MATERIAL NO. SEE BOM TABLE DOCUMENT NO. SD-34566-001 SHEET NO. 4 OF 68
		mm	INCH																					
4 PLACES	±----	+---																						
3 PLACES	±----	±---																						
2 PLACES	±----	±---																						
1 PLACE	±----	±---																						
0 PLACE	±----	±---																						
THIS DRAWING CONTAINS INFORMATION THAT IS PROPRIETARY TO MOLEX INCORPORATED AND SHOULD NOT BE USED WITHOUT WRITTEN PERMISSION																								

STATUS	GM PART #	MATERIAL #	PART / MATERIAL REVISION	WIRE DRESS OPTION	KEY OPTION	COLOR (TPA)	NUMBERS INDICATE CAVITIES OPEN FOR CIRCUITS
AVAILABLE	12582677	34566-003	G	0	A	BLACK	
AVAILABLE	12582678	34566-0203	G	0	B	ST GRY	72 71 70 69 68 67 66 65 64 63 62 61 60 59 58 57 56 55 54 53
AVAILABLE	12615654	34566-0303	G	0	C	BLUE	52 51 50 49 48 47 46 45 44 43 42 41 40 39 38 37 36 35 34 33
ACTIVE	12615660	34566-0403	G	0	D	BROWN	73 32 31 30 29 28 27 26 25 24 23 22 21 20 19 18 17
ACTIVE	12615661	34566-0503	G	0	E	GREEN	16 15 14 13 12 11 10 9 8 7 6 5 4 3 2 1
ACTIVE	12615662	34566-0603	G	0	F	NATURAL	
AVAILABLE	12588057	34566-0703	G	0	G	BLUE	
AVAILABLE	12588058	34566-0803	G	0	H	ST GRY	80 79 78 77 76 75 74 73 72 71 70 69 68 67 66 65 64 63 62 61
ACTIVE	12615658	34566-0903	G	0	J	BLACK	60 59 58 57 56 55 54 53 52 51 50 49 48 47 46 45 44 43 42 41
ACTIVE	TBD	34566-1003	G	0	K	BROWN	40 39 38 37 36 35 34 33 32 31 30 29 28 27 26 25 24 23 22 21
ACTIVE	TBD	34566-1103	G	0	L	GREEN	20 19 18 17 16 15 14 13 12 11 10 9 8 7 6 5 4 3 2 1
ACTIVE	TBD	34566-1203	G	0	M	NATURAL	
AVAILABLE	12603596	34566-1303	G	9	A	BLACK	
AVAILABLE	12603597	34566-1403	G	9	B	ST GRY	72 71 70 69 68 67 66 65 64 63 62 61 60 59 58 57 56 55 54 53
AVAILABLE	12615655	34566-1503	G	9	C	BLUE	52 51 50 49 48 47 46 45 44 43 42 41 40 39 38 37 36 35 34 33
ACTIVE	12615663	34566-1603	G	9	D	BROWN	73 32 31 30 29 28 27 26 25 24 23 22 21 20 19 18 17
ACTIVE	12615664	34566-1703	G	9	E	GREEN	16 15 14 13 12 11 10 9 8 7 6 5 4 3 2 1
ACTIVE	12615665	34566-1803	G	9	F	NATURAL	
AVAILABLE	12603598	34566-1903	G	9	G	BLUE	
AVAILABLE	12603599	34566-2003	G	9	H	ST GRY	80 79 78 77 76 75 74 73 72 71 70 69 68 67 66 65 64 63 62 61
ACTIVE	12615659	34566-2103	G	9	J	BLACK	60 59 58 57 56 55 54 53 52 51 50 49 48 47 46 45 44 43 42 41
ACTIVE	TBD	34566-2203	G	9	K	BROWN	40 39 38 37 36 35 34 33 32 31 30 29 28 27 26 25 24 23 22 21
ACTIVE	TBD	34566-2303	G	9	L	GREEN	20 19 18 17 16 15 14 13 12 11 10 9 8 7 6 5 4 3 2 1
ACTIVE	TBD	34566-2403	G	9	M	NATURAL	
ACTIVE	TBD	34822-0013	A	0	A	BLACK	64 63 62 61 60 59 58 57 56 55 54 53 52 51 50 49 66
ACTIVE	TBD	34822-0033	A	0	C	BLUE	48 47 46 45 44 43 42 41 40 39 38 37 36 35 34 33 65
ACTIVE	TBD	34822-0023	A	9	A	BLACK	32 31 30 29 28 27 26 25 24 23 22 21 20 19 18 17
ACTIVE	TBD	34822-0043	A	9	C	BLUE	16 15 14 13 12 11 10 9 8 7 6 5 4 3 2 1
N/A	N/A	N/A	N/A	N/A	N/A	N/A	
AVAILABLE	NOT APPLICABLE	34566-2503	G	0	A	BLACK	72 71 69 68 67 66 64 63 62 59 56 53
							50 48 46 44 43 42 39 36 35 33
							73 32 30 29 27 23 20 17
							14 13 12 11 9 8 5 4 3 2 1

SEE NEXT PAGE FOR ADDITIONAL NUMBERS

ENTER DESCRIPTION ELEC NO: UAU2014-0376 DRAWN BY: CHOK CHKD: APPR:KOSHY 2013/09/05 2013/09/06 65	QUALITY SYMBOLS ∇=0 ∇=0 ∇=0	GENERAL TOLERANCES (UNLESS SPECIFIED) mm INCH 4 PLACES +--- +--- 3 PLACES +--- +--- 2 PLACES +--- +--- 1 PLACE +--- +--- 0 PLACE +--- +--- ANGULAR ±---° DRAFT WHERE APPLICABLE MUST REMAIN WITHIN DIMENSIONS	DIMENSION STYLE MM ONLY	SCALE DESIGN UNITS METRIC	THIRD ANGLE PROJECTION
	DRAWN BY: SKRAJENDRANA DATE: 2011/02/14 CHECKED BY: MYANSLAMBROU DATE: 2011/02/14 APPROVED BY:	TITLE MX123 66/73/80CKT HRNS CONN ASSY	MATERIAL NO. SD-34566-001	DOCUMENT NO. SHEET NO. 5 OF 68	
	THIS DRAWING CONTAINS INFORMATION THAT IS PROPRIETARY TO MOLEX INCORPORATED AND SHOULD NOT BE USED WITHOUT WRITTEN PERMISSION				

STATUS	GM PART #	MATERIAL #	PART/MATERIAL REVISION	WIRE DRESS OPTION	KEY OPTION	COLOR (TPA)	NUMBERS INDICATE CAVITIES OPEN FOR CIRCUITS																																																																																	
AVAILABLE	NOT APPLICABLE	34566-2603	G	0	B	ST GR	<table border="1"> <tr><td></td><td></td><td></td><td></td><td>67</td><td>66</td><td>65</td><td></td><td></td><td></td><td></td><td></td><td>59</td><td>57</td><td>55</td><td>53</td></tr> <tr><td></td><td></td><td>49</td><td>48</td><td>47</td><td></td><td></td><td>44</td><td></td><td></td><td></td><td></td><td>39</td><td>37</td><td>35</td><td>33</td></tr> <tr><td>73</td><td></td><td></td><td></td><td></td><td></td><td>29</td><td>28</td><td></td><td></td><td></td><td></td><td>23</td><td>21</td><td></td><td></td></tr> <tr><td></td><td></td><td></td><td></td><td></td><td></td><td></td><td></td><td></td><td></td><td></td><td></td><td>7</td><td></td><td></td><td></td></tr> </table>					67	66	65						59	57	55	53			49	48	47			44					39	37	35	33	73						29	28					23	21															7																				
				67	66	65						59	57	55	53																																																																									
		49	48	47			44					39	37	35	33																																																																									
73						29	28					23	21																																																																											
												7																																																																												
AVAILABLE	NOT APPLICABLE	34566-2703	G	0	B	ST GR	<table border="1"> <tr><td></td><td></td><td></td><td></td><td></td><td></td><td>65</td><td></td><td></td><td></td><td></td><td></td><td>59</td><td>57</td><td>55</td><td>53</td></tr> <tr><td></td><td></td><td>49</td><td>48</td><td>47</td><td></td><td></td><td>44</td><td></td><td></td><td></td><td></td><td>39</td><td>37</td><td>35</td><td>33</td></tr> <tr><td>73</td><td></td><td></td><td></td><td></td><td></td><td>29</td><td>28</td><td></td><td></td><td></td><td></td><td>23</td><td>21</td><td></td><td></td></tr> <tr><td></td><td></td><td></td><td></td><td></td><td></td><td></td><td></td><td></td><td></td><td></td><td></td><td>7</td><td></td><td></td><td></td></tr> </table>							65						59	57	55	53			49	48	47			44					39	37	35	33	73						29	28					23	21															7																				
						65						59	57	55	53																																																																									
		49	48	47			44					39	37	35	33																																																																									
73						29	28					23	21																																																																											
												7																																																																												
AVAILABLE	NOT APPLICABLE	34566-2803	G	0	H	ST GR	<table border="1"> <tr><td></td><td></td><td></td><td></td><td></td><td></td><td></td><td></td><td></td><td></td><td></td><td></td><td></td><td></td><td></td><td></td></tr> <tr><td></td><td></td><td></td><td></td><td></td><td></td><td></td><td></td><td></td><td></td><td></td><td></td><td></td><td></td><td></td><td></td></tr> <tr><td></td><td></td><td></td><td></td><td></td><td></td><td></td><td></td><td></td><td></td><td></td><td></td><td></td><td></td><td></td><td></td></tr> <tr><td></td><td></td><td></td><td></td><td></td><td></td><td></td><td></td><td></td><td></td><td></td><td></td><td></td><td></td><td></td><td></td></tr> </table>																																																																																	
AVAILABLE	NOT APPLICABLE	34566-2903	G	0	A	BLACK	<table border="1"> <tr><td>72</td><td>71</td><td>70</td><td>69</td><td>68</td><td>67</td><td>66</td><td></td><td>64</td><td>63</td><td>62</td><td>61</td><td></td><td>59</td><td></td><td></td><td>55</td><td>54</td><td>53</td></tr> <tr><td>52</td><td>51</td><td></td><td>49</td><td>48</td><td></td><td></td><td></td><td>44</td><td>43</td><td>42</td><td>41</td><td></td><td>39</td><td></td><td></td><td></td><td>35</td><td>34</td><td>33</td></tr> <tr><td></td><td></td><td></td><td>32</td><td>31</td><td></td><td></td><td>29</td><td></td><td>27</td><td></td><td>25</td><td>24</td><td>23</td><td></td><td></td><td>19</td><td>18</td><td>17</td></tr> <tr><td>73</td><td></td><td></td><td></td><td>16</td><td></td><td></td><td>13</td><td>12</td><td>11</td><td></td><td>9</td><td>8</td><td>7</td><td>6</td><td>5</td><td>4</td><td>3</td><td>2</td><td>1</td></tr> </table>	72	71	70	69	68	67	66		64	63	62	61		59			55	54	53	52	51		49	48				44	43	42	41		39				35	34	33				32	31			29		27		25	24	23			19	18	17	73				16			13	12	11		9	8	7	6	5	4	3	2	1			
72	71	70	69	68	67	66		64	63	62	61		59			55	54	53																																																																						
52	51		49	48				44	43	42	41		39				35	34	33																																																																					
			32	31			29		27		25	24	23			19	18	17																																																																						
73				16			13	12	11		9	8	7	6	5	4	3	2	1																																																																					
AVAILABLE	NOT APPLICABLE	34566-3003	G	0	A	BLACK	<table border="1"> <tr><td>72</td><td>71</td><td>70</td><td>69</td><td>68</td><td>67</td><td>66</td><td></td><td>64</td><td>63</td><td>62</td><td></td><td>60</td><td>59</td><td>58</td><td>57</td><td>56</td><td>55</td><td>54</td><td>53</td></tr> <tr><td>52</td><td>51</td><td>50</td><td>49</td><td>48</td><td>47</td><td>46</td><td></td><td>44</td><td>43</td><td>42</td><td>41</td><td>40</td><td>39</td><td>38</td><td>37</td><td>36</td><td>35</td><td>34</td><td>33</td></tr> <tr><td></td><td></td><td></td><td>32</td><td>31</td><td>30</td><td>29</td><td>28</td><td>27</td><td></td><td>25</td><td>24</td><td>23</td><td>22</td><td>21</td><td>20</td><td>19</td><td>18</td><td>17</td><td></td></tr> <tr><td>73</td><td></td><td></td><td>16</td><td>15</td><td>14</td><td>13</td><td>12</td><td>11</td><td></td><td>9</td><td>8</td><td>7</td><td>6</td><td>5</td><td>4</td><td>3</td><td>2</td><td>1</td><td></td></tr> </table>	72	71	70	69	68	67	66		64	63	62		60	59	58	57	56	55	54	53	52	51	50	49	48	47	46		44	43	42	41	40	39	38	37	36	35	34	33				32	31	30	29	28	27		25	24	23	22	21	20	19	18	17		73			16	15	14	13	12	11		9	8	7	6	5	4	3	2	1		
72	71	70	69	68	67	66		64	63	62		60	59	58	57	56	55	54	53																																																																					
52	51	50	49	48	47	46		44	43	42	41	40	39	38	37	36	35	34	33																																																																					
			32	31	30	29	28	27		25	24	23	22	21	20	19	18	17																																																																						
73			16	15	14	13	12	11		9	8	7	6	5	4	3	2	1																																																																						
AVAILABLE	NOT APPLICABLE	34566-3103	G	0	B	ST GR	<table border="1"> <tr><td></td><td></td><td></td><td></td><td></td><td></td><td></td><td>65</td><td></td><td></td><td>62</td><td></td><td>59</td><td></td><td>57</td><td></td><td>55</td><td></td><td>53</td></tr> <tr><td></td><td></td><td>49</td><td>48</td><td></td><td></td><td>46</td><td></td><td></td><td></td><td>42</td><td></td><td>39</td><td></td><td>37</td><td></td><td>35</td><td></td><td>33</td></tr> <tr><td>73</td><td></td><td></td><td></td><td></td><td></td><td></td><td>29</td><td></td><td></td><td>26</td><td></td><td>23</td><td></td><td>21</td><td></td><td></td><td></td><td>18</td></tr> <tr><td></td><td></td><td></td><td>15</td><td></td><td></td><td></td><td></td><td></td><td></td><td>9</td><td>8</td><td>7</td><td></td><td></td><td>4</td><td>3</td><td></td><td></td></tr> </table>								65			62		59		57		55		53			49	48			46				42		39		37		35		33	73							29			26		23		21				18				15							9	8	7			4	3							
							65			62		59		57		55		53																																																																						
		49	48			46				42		39		37		35		33																																																																						
73							29			26		23		21				18																																																																						
			15							9	8	7			4	3																																																																								
AVAILABLE	NOT APPLICABLE	34566-3203	G	0	B	ST GR	<table border="1"> <tr><td></td><td></td><td></td><td></td><td></td><td>67</td><td></td><td></td><td></td><td></td><td></td><td></td><td></td><td>60</td><td>59</td><td>58</td><td>57</td><td>56</td><td>55</td><td>53</td></tr> <tr><td></td><td></td><td>50</td><td>49</td><td>48</td><td></td><td>46</td><td></td><td></td><td></td><td></td><td></td><td></td><td>39</td><td>38</td><td>37</td><td></td><td>35</td><td>34</td><td>33</td></tr> <tr><td>73</td><td></td><td></td><td></td><td></td><td></td><td></td><td>29</td><td></td><td></td><td></td><td></td><td></td><td>23</td><td>22</td><td>21</td><td></td><td></td><td>18</td><td></td></tr> <tr><td></td><td></td><td></td><td>16</td><td>15</td><td>14</td><td></td><td></td><td></td><td></td><td></td><td></td><td></td><td>7</td><td>6</td><td>5</td><td>4</td><td>3</td><td></td><td></td></tr> </table>						67								60	59	58	57	56	55	53			50	49	48		46							39	38	37		35	34	33	73							29						23	22	21			18					16	15	14								7	6	5	4	3			
					67								60	59	58	57	56	55	53																																																																					
		50	49	48		46							39	38	37		35	34	33																																																																					
73							29						23	22	21			18																																																																						
			16	15	14								7	6	5	4	3																																																																							
AVAILABLE	NOT APPLICABLE	34566-3303	G	0	B	ST GR	<table border="1"> <tr><td></td><td></td><td></td><td></td><td></td><td></td><td></td><td></td><td></td><td></td><td></td><td></td><td></td><td>59</td><td>58</td><td>57</td><td>56</td><td>55</td><td>53</td></tr> <tr><td></td><td></td><td>50</td><td>49</td><td>48</td><td></td><td>46</td><td></td><td></td><td></td><td></td><td></td><td></td><td>39</td><td>38</td><td>37</td><td></td><td>35</td><td>34</td><td>33</td></tr> <tr><td>73</td><td></td><td></td><td></td><td></td><td></td><td></td><td>29</td><td></td><td></td><td></td><td></td><td></td><td>23</td><td>22</td><td>21</td><td></td><td></td><td>18</td><td></td></tr> <tr><td></td><td></td><td></td><td>16</td><td>15</td><td>14</td><td></td><td></td><td></td><td></td><td></td><td></td><td></td><td>7</td><td>6</td><td>5</td><td>4</td><td>3</td><td></td><td></td></tr> </table>														59	58	57	56	55	53			50	49	48		46							39	38	37		35	34	33	73							29						23	22	21			18					16	15	14								7	6	5	4	3				
													59	58	57	56	55	53																																																																						
		50	49	48		46							39	38	37		35	34	33																																																																					
73							29						23	22	21			18																																																																						
			16	15	14								7	6	5	4	3																																																																							
AVAILABLE	NOT APPLICABLE	34566-3403					SEE 34566-3003																																																																																	
AVAILABLE	NOT APPLICABLE	34566-3503	G	0	A	BLACK	<table border="1"> <tr><td>72</td><td>71</td><td></td><td>69</td><td>68</td><td>67</td><td>66</td><td></td><td>64</td><td>63</td><td>62</td><td></td><td>60</td><td>59</td><td></td><td></td><td></td><td></td><td></td><td></td></tr> <tr><td>52</td><td></td><td></td><td>49</td><td>48</td><td></td><td>46</td><td></td><td>44</td><td>43</td><td>42</td><td></td><td>40</td><td>39</td><td></td><td></td><td></td><td></td><td>35</td><td>33</td></tr> <tr><td></td><td></td><td></td><td>32</td><td></td><td></td><td>29</td><td></td><td></td><td>27</td><td></td><td></td><td>24</td><td>23</td><td></td><td></td><td></td><td></td><td></td><td>17</td></tr> <tr><td>73</td><td></td><td></td><td></td><td></td><td></td><td></td><td>14</td><td>13</td><td>12</td><td>11</td><td></td><td>9</td><td>8</td><td>7</td><td>6</td><td>5</td><td>4</td><td>3</td><td>2</td><td>1</td></tr> </table>	72	71		69	68	67	66		64	63	62		60	59							52			49	48		46		44	43	42		40	39					35	33				32			29			27			24	23						17	73							14	13	12	11		9	8	7	6	5	4	3	2	1
72	71		69	68	67	66		64	63	62		60	59																																																																											
52			49	48		46		44	43	42		40	39					35	33																																																																					
			32			29			27			24	23						17																																																																					
73							14	13	12	11		9	8	7	6	5	4	3	2	1																																																																				

SEE NEXT PAGE FOR ADDITIONAL NUMBERS

ENTER DESCRIPTION IEC NO: UAU2014-0376 DRAWN BY: CHKD CHCK: APPR: IKOSHY 2013/09/05 2013/09/06	QUALITY SYMBOLS	GENERAL TOLERANCES (UNLESS SPECIFIED)	DIMENSION STYLE	SCALE	DESIGN UNITS	THIRD ANGLE PROJECTION
	▽=0	4 PLACES ± mm INCH	MM ONLY		METRIC	
	▽=0	3 PLACES ±	DRAWN BY DATE	TITLE		
	▽=0	2 PLACES ±	CHECKED BY DATE	MX123 66/73/80CKT HRNS CONN ASSY		
	1 PLACE ±	APPROVED BY DATE	molex			
	0 PLACE ±	ANGULAR ±	SEE BOM TABLE			
DRAFT WHERE APPLICABLE MUST REMAIN WITHIN DIMENSIONS		MATERIAL NO.	DOCUMENT NO.		SHEET NO.	
		SD-34566-001		6 OF 68		
THIS DRAWING CONTAINS INFORMATION THAT IS PROPRIETARY TO MOLEX INCORPORATED AND SHOULD NOT BE USED WITHOUT WRITTEN PERMISSION						

STATUS	GM PART #	MATERIAL #	PART/ MATERIAL REVISION	WIRE DRESS OPTION	KEY OPTION ▽	COLOR (TPA) ▽	NUMBERS INDICATE CAVITIES OPEN FOR CIRCUITS ▽																																																																																
AVAILABLE	NOT APPLICABLE	34566-3603	G	0	B	ST GRAY	<table border="1"> <tr><td></td><td></td><td></td><td>68</td><td></td><td></td><td></td><td>64</td><td></td><td></td><td></td><td></td><td></td><td>59</td><td>57</td><td>55</td><td>53</td></tr> <tr><td></td><td></td><td>49</td><td>48</td><td>46</td><td></td><td></td><td></td><td></td><td></td><td></td><td></td><td></td><td>39</td><td>37</td><td>35</td><td>33</td></tr> <tr><td>73</td><td></td><td>32</td><td></td><td>29</td><td></td><td></td><td></td><td></td><td></td><td></td><td></td><td></td><td>23</td><td>21</td><td></td><td>18</td></tr> <tr><td></td><td></td><td></td><td></td><td></td><td></td><td></td><td>11</td><td>10</td><td></td><td></td><td></td><td></td><td>7</td><td></td><td></td><td></td></tr> </table>				68				64						59	57	55	53			49	48	46									39	37	35	33	73		32		29									23	21		18								11	10					7															
			68				64						59	57	55	53																																																																							
		49	48	46									39	37	35	33																																																																							
73		32		29									23	21		18																																																																							
							11	10					7																																																																										
AVAILABLE	NOT APPLICABLE	34566-3703	G	0	A	BLACK	<table border="1"> <tr><td></td><td></td><td></td><td>68</td><td>67</td><td>66</td><td>65</td><td></td><td></td><td></td><td></td><td></td><td></td><td>59</td><td></td><td>55</td><td>53</td></tr> <tr><td></td><td></td><td>49</td><td>48</td><td>47</td><td></td><td>44</td><td></td><td></td><td></td><td></td><td></td><td></td><td>39</td><td></td><td>35</td><td>33</td></tr> <tr><td>73</td><td></td><td></td><td></td><td></td><td></td><td>29</td><td>28</td><td></td><td></td><td></td><td></td><td></td><td>23</td><td></td><td></td><td></td></tr> <tr><td></td><td></td><td></td><td></td><td></td><td></td><td></td><td></td><td></td><td></td><td></td><td></td><td></td><td>7</td><td></td><td></td><td></td></tr> </table>				68	67	66	65							59		55	53			49	48	47		44							39		35	33	73						29	28						23																	7															
			68	67	66	65							59		55	53																																																																							
		49	48	47		44							39		35	33																																																																							
73						29	28						23																																																																										
													7																																																																										
AVAILABLE	NOT APPLICABLE	34566-3803	G	0	A	BLACK	<table border="1"> <tr><td>72</td><td>71</td><td></td><td>69</td><td>68</td><td>67</td><td>66</td><td></td><td>64</td><td>63</td><td>62</td><td></td><td></td><td>59</td><td></td><td>56</td><td>53</td></tr> <tr><td></td><td></td><td>50</td><td></td><td>48</td><td>46</td><td>44</td><td>43</td><td>42</td><td></td><td></td><td></td><td></td><td>39</td><td></td><td>36</td><td>33</td></tr> <tr><td></td><td></td><td></td><td></td><td>32</td><td></td><td>30</td><td>29</td><td>27</td><td></td><td></td><td></td><td></td><td>23</td><td></td><td>20</td><td>17</td></tr> <tr><td>73</td><td></td><td></td><td></td><td></td><td></td><td>14</td><td>13</td><td>12</td><td>11</td><td>10</td><td>9</td><td>8</td><td></td><td>5</td><td>4</td><td>3</td><td>2</td><td>1</td></tr> </table>	72	71		69	68	67	66		64	63	62			59		56	53			50		48	46	44	43	42					39		36	33					32		30	29	27					23		20	17	73						14	13	12	11	10	9	8		5	4	3	2	1										
72	71		69	68	67	66		64	63	62			59		56	53																																																																							
		50		48	46	44	43	42					39		36	33																																																																							
				32		30	29	27					23		20	17																																																																							
73						14	13	12	11	10	9	8		5	4	3	2	1																																																																					
AVAILABLE	NOT APPLICABLE	34566-3903	G	0	B	ST GRAY	<table border="1"> <tr><td></td><td></td><td></td><td></td><td></td><td></td><td></td><td>65</td><td></td><td></td><td></td><td></td><td></td><td>59</td><td>57</td><td>55</td><td>53</td></tr> <tr><td></td><td></td><td>49</td><td>48</td><td></td><td></td><td></td><td>44</td><td></td><td></td><td></td><td></td><td></td><td>39</td><td>37</td><td>35</td><td>33</td></tr> <tr><td>73</td><td></td><td></td><td></td><td></td><td></td><td></td><td>29</td><td>28</td><td></td><td></td><td></td><td></td><td>24</td><td>23</td><td>21</td><td></td></tr> <tr><td></td><td></td><td></td><td></td><td></td><td></td><td></td><td></td><td></td><td></td><td></td><td></td><td></td><td>7</td><td></td><td></td><td></td></tr> </table>								65						59	57	55	53			49	48				44						39	37	35	33	73							29	28					24	23	21															7															
							65						59	57	55	53																																																																							
		49	48				44						39	37	35	33																																																																							
73							29	28					24	23	21																																																																								
													7																																																																										
AVAILABLE	NOT APPLICABLE	34566-4003	G	0	B	ST GRAY	<table border="1"> <tr><td></td><td></td><td></td><td></td><td></td><td>67</td><td>66</td><td></td><td>64</td><td>63</td><td></td><td></td><td></td><td>59</td><td>57</td><td>55</td><td>53</td></tr> <tr><td></td><td></td><td>50</td><td>49</td><td>48</td><td></td><td></td><td></td><td>43</td><td></td><td></td><td></td><td></td><td>39</td><td>37</td><td>35</td><td>33</td></tr> <tr><td>73</td><td></td><td></td><td></td><td>32</td><td></td><td></td><td></td><td>29</td><td>27</td><td></td><td></td><td></td><td>24</td><td>23</td><td>21</td><td>18</td></tr> <tr><td></td><td></td><td></td><td></td><td></td><td>15</td><td></td><td></td><td></td><td></td><td></td><td></td><td></td><td>7</td><td>6</td><td>5</td><td>4</td><td>3</td></tr> </table>						67	66		64	63				59	57	55	53			50	49	48				43					39	37	35	33	73				32				29	27				24	23	21	18						15								7	6	5	4	3											
					67	66		64	63				59	57	55	53																																																																							
		50	49	48				43					39	37	35	33																																																																							
73				32				29	27				24	23	21	18																																																																							
					15								7	6	5	4	3																																																																						
AVAILABLE	NOT APPLICABLE	34566-4103	G	0	A	BLACK	<table border="1"> <tr><td>72</td><td>71</td><td></td><td>69</td><td>68</td><td>67</td><td>66</td><td></td><td>64</td><td>63</td><td>62</td><td></td><td></td><td>60</td><td>59</td><td></td><td></td><td></td><td></td></tr> <tr><td>52</td><td></td><td></td><td>49</td><td>48</td><td>46</td><td>45</td><td>44</td><td>43</td><td>42</td><td></td><td></td><td></td><td>40</td><td>39</td><td></td><td></td><td>35</td><td>33</td></tr> <tr><td></td><td></td><td></td><td></td><td>32</td><td></td><td></td><td></td><td>29</td><td>27</td><td>26</td><td></td><td></td><td>24</td><td>23</td><td></td><td></td><td></td><td>17</td></tr> <tr><td>73</td><td></td><td></td><td></td><td></td><td></td><td></td><td></td><td>14</td><td>13</td><td>12</td><td>11</td><td>10</td><td>9</td><td>8</td><td>7</td><td>6</td><td>5</td><td>4</td><td>3</td><td>2</td><td>1</td></tr> </table>	72	71		69	68	67	66		64	63	62			60	59					52			49	48	46	45	44	43	42				40	39			35	33					32				29	27	26			24	23				17	73								14	13	12	11	10	9	8	7	6	5	4	3	2	1	
72	71		69	68	67	66		64	63	62			60	59																																																																									
52			49	48	46	45	44	43	42				40	39			35	33																																																																					
				32				29	27	26			24	23				17																																																																					
73								14	13	12	11	10	9	8	7	6	5	4	3	2	1																																																																		
AVAILABLE	NOT APPLICABLE	34566-4203	G	0	B	ST GRAY	<table border="1"> <tr><td></td><td></td><td></td><td></td><td></td><td></td><td></td><td></td><td></td><td></td><td></td><td></td><td></td><td>59</td><td>57</td><td>55</td><td>53</td></tr> <tr><td></td><td></td><td>50</td><td>49</td><td>48</td><td></td><td></td><td></td><td></td><td></td><td></td><td></td><td></td><td>39</td><td>37</td><td>35</td><td>33</td></tr> <tr><td>73</td><td></td><td></td><td></td><td>32</td><td></td><td></td><td></td><td>29</td><td></td><td></td><td></td><td></td><td>24</td><td>23</td><td>21</td><td>18</td></tr> <tr><td></td><td></td><td></td><td></td><td></td><td>15</td><td></td><td></td><td></td><td></td><td></td><td></td><td></td><td>7</td><td>6</td><td>5</td><td>4</td><td>3</td><td></td><td></td></tr> </table>														59	57	55	53			50	49	48									39	37	35	33	73				32				29					24	23	21	18						15								7	6	5	4	3											
													59	57	55	53																																																																							
		50	49	48									39	37	35	33																																																																							
73				32				29					24	23	21	18																																																																							
					15								7	6	5	4	3																																																																						
AVAILABLE	NOT APPLICABLE	34566-4303	G	0	A	BLACK	<table border="1"> <tr><td></td><td></td><td>70</td><td>69</td><td>68</td><td>67</td><td></td><td>65</td><td>64</td><td>63</td><td></td><td>61</td><td>59</td><td>58</td><td>57</td><td>56</td><td></td><td></td><td></td><td></td></tr> <tr><td></td><td></td><td>50</td><td>49</td><td>48</td><td>47</td><td></td><td></td><td></td><td></td><td></td><td>41</td><td></td><td>38</td><td>37</td><td>36</td><td></td><td></td><td>34</td><td>33</td></tr> <tr><td></td><td></td><td></td><td></td><td>32</td><td>31</td><td>30</td><td>29</td><td>28</td><td>27</td><td></td><td></td><td>24</td><td>23</td><td></td><td></td><td>20</td><td>19</td><td>18</td><td></td></tr> <tr><td>73</td><td></td><td></td><td></td><td></td><td>16</td><td></td><td></td><td></td><td></td><td>13</td><td>12</td><td>11</td><td>10</td><td>9</td><td></td><td></td><td></td><td></td><td>1</td></tr> </table>			70	69	68	67		65	64	63		61	59	58	57	56							50	49	48	47						41		38	37	36			34	33					32	31	30	29	28	27			24	23			20	19	18		73					16					13	12	11	10	9					1
		70	69	68	67		65	64	63		61	59	58	57	56																																																																								
		50	49	48	47						41		38	37	36			34	33																																																																				
				32	31	30	29	28	27			24	23			20	19	18																																																																					
73					16					13	12	11	10	9					1																																																																				

SEE NEXT PAGE FOR ADDITIONAL NUMBERS

ENTER DESCRIPTION IEC NO: UAU2014-0376 DRAWN BY: 2013/09/05 CHKD: 2013/09/06 APPR: WOSHY REV: 05	QUALITY SYMBOLS ▽=0 ▽=0 ▽=0	GENERAL TOLERANCES (UNLESS SPECIFIED) mm INCH 4 PLACES ±--- ±--- 3 PLACES ±--- ±--- 2 PLACES ±--- ±--- 1 PLACE ±--- ±--- 0 PLACE ±--- ±--- ANGULAR ±---° DRAFT WHERE APPLICABLE MUST REMAIN WITHIN DIMENSIONS	DIMENSION STYLE MM ONLY DRAWN BY: SKRA JENDRANA 2011/02/14 CHECKED BY: MVANSLAMBROU 2011/02/14 APPROVED BY:	SCALE: METRIC DESIGN UNITS: METRIC THIRD ANGLE PROJECTION	TITLE: MX123 66/73/80CKT HRNS CONN ASSY molex MATERIAL NO. SD-34566-001 DOCUMENT NO.	SHEET NO. 7 OF 68
	SEE BOM TABLE			THIS DRAWING CONTAINS INFORMATION THAT IS PROPRIETARY TO MOLEX INCORPORATED AND SHOULD NOT BE USED WITHOUT WRITTEN PERMISSION		

STATUS	GM PART #	MATERIAL #	PART/MATERIAL REVISION	WIRE DRESS OPTION	KEY OPTION	COLOR (TPA)	NUMBERS INDICATE CAVITIES OPEN FOR CIRCUITS	
AVAILABLE	NOT APPLICABLE	34566-4403	G	0	A	BLACK	72 71 70 69 68 67 66 65 64 63 61 59 58 57 56 34 33	73 32 31 30 29 28 27 24 23 20 19 18 16 15 14 13 12 11 10 9 8 7 6 5 4 3 2 1
AVAILABLE	NOT APPLICABLE	34566-4503	G	0	H	ST GR Y	79 78 77 76 75 74 73 72 71 70 69 68 66 65 64 63 61 60 59 58 57 56 53 50 44 43 41 40 39 38 37 35 34 33 32 30 29 27 26 24 23 22 21 20 19 18 17 16 15 14 13 12 11 10 9 8 6 5 4 3 2 1	
AVAILABLE	NOT APPLICABLE	34566-4603	G	0	H	ST GR Y	79 78 77 76 75 74 73 72 71 70 69 68 66 65 64 63 61 60 59 58 57 56 53 50 44 43 41 40 39 38 37 35 34 33 32 30 29 27 26 24 23 22 21 20 19 18 17 16 15 14 13 12 11 10 9 8 6 5 4 3 2 1	
AVAILABLE	NOT APPLICABLE	34566-4703	G	0	B	ST GR Y	67 66 65 64 59 58 57 55 53 49 48 47 44 29 23 22 21 73 7 39 38 37 35 33	
AVAILABLE	NOT APPLICABLE	34566-4803	G	0	A	BLACK	72 71 69 68 67 66 64 63 62 61 59 39 35 33 73 72 71 70 69 68 66 65 64 63 62 61 59 58 57 56 35 34 33 32 31 30 29 28 27 25 23 21 17 16 15 14 13 12 11 10 9 8 6 5 4 3 2 1	
AVAILABLE	NOT APPLICABLE	34566-4903	G	0	A	BLACK	72 71 70 69 68 67 66 65 64 63 62 61 59 58 57 56 55 52 51 50 49 47 44 43 41 38 37 36 35 34 33 32 31 30 29 28 27 24 23 20 19 18 17 16 15 14 13 12 11 10 9 8 6 5 4 3 2 1	
AVAILABLE	NOT APPLICABLE	34566-5003	G	0	H	ST GR Y	79 78 77 76 75 74 73 72 71 70 69 68 66 65 64 63 61 60 59 58 57 56 53 52 50 44 43 41 40 39 38 37 35 34 33 32 30 29 27 26 24 23 22 21 20 19 18 17 16 15 14 13 12 11 10 9 8 6 5 4 3 2 1	
AVAILABLE	NOT APPLICABLE	34566-5103	G	0	B	ST GR Y	67 66 65 59 57 55 53 49 48 47 46 44 29 28 23 21 73 7 39 37 35 33	
SEE NEXT PAGE FOR ADDITIONAL NUMBERS								

ENTER DESCRIPTION IEC NO: UAU2014-0376 DRAWN BY: 2013/09/05 CHKD: APPR: IKOSHY REV: 05	QUALITY SYMBOLS ∇=0 ∇=0 ∇=0	GENERAL TOLERANCES (UNLESS SPECIFIED) mm INCH	DIMENSION STYLE MM ONLY	SCALE METRIC	DESIGN UNITS METRIC	THIRD ANGLE PROJECTION
		4 PLACES ±---+--- 3 PLACES ±---+--- 2 PLACES ±---+--- 1 PLACE ±---+--- 0 PLACE ±---+---	DRAWN BY: SKRAJENDRANA 2011/02/14 CHECKED BY: MVANSLAMBROU 2011/02/14 APPROVED BY:	DATE:	TITLE MX123 66/73/80CKT HRNS CONN ASSY molex	
		ANGULAR ±---° DRAFT WHERE APPLICABLE MUST REMAIN WITHIN DIMENSIONS	MATERIAL NO. SEE BOM TABLE	DOCUMENT NO. SD-34566-001	SHEET NO. 8 OF 68	
THIS DRAWING CONTAINS INFORMATION THAT IS PROPRIETARY TO MOLEX INCORPORATED AND SHOULD NOT BE USED WITHOUT WRITTEN PERMISSION						

20 19 18 17 16 15 14 13 12 11 10 9 8 7 6 5 4 3 2 1

STATUS	GM PART #	MATERIAL #	PART/MATERIAL REVISION	WIRE DRESS OPTION	KEY OPTION	COLOR (TPA)	NUMBERS INDICATE CAVITIES OPEN FOR CIRCUITS																																																																												
AVAILABLE	NOT APPLICABLE	34566-5203	G	0	A	BLACK	<table border="1"> <tr><td>72</td><td>71</td><td>69</td><td>68</td><td>67</td><td>66</td><td>64</td><td>63</td><td>62</td><td></td><td>59</td><td>58</td><td>57</td><td>56</td><td>54</td><td>53</td></tr> <tr><td>52</td><td>51</td><td>50</td><td>49</td><td>48</td><td>47</td><td>46</td><td>44</td><td>43</td><td>42</td><td></td><td>39</td><td>38</td><td>37</td><td>36</td><td>34</td><td>33</td></tr> <tr><td></td><td></td><td></td><td>32</td><td>31</td><td>30</td><td>29</td><td></td><td>27</td><td></td><td>24</td><td>23</td><td>22</td><td>21</td><td>20</td><td>19</td><td>17</td></tr> <tr><td>73</td><td></td><td></td><td>15</td><td>14</td><td>13</td><td>12</td><td>11</td><td></td><td>9</td><td>8</td><td>7</td><td>6</td><td>5</td><td>4</td><td>3</td><td>2</td><td>1</td></tr> </table>	72	71	69	68	67	66	64	63	62		59	58	57	56	54	53	52	51	50	49	48	47	46	44	43	42		39	38	37	36	34	33				32	31	30	29		27		24	23	22	21	20	19	17	73			15	14	13	12	11		9	8	7	6	5	4	3	2	1								
72	71	69	68	67	66	64	63	62		59	58	57	56	54	53																																																																				
52	51	50	49	48	47	46	44	43	42		39	38	37	36	34	33																																																																			
			32	31	30	29		27		24	23	22	21	20	19	17																																																																			
73			15	14	13	12	11		9	8	7	6	5	4	3	2	1																																																																		
AVAILABLE	NOT APPLICABLE	34566-5303	G	0	B	ST GRY	<table border="1"> <tr><td></td><td></td><td></td><td></td><td></td><td></td><td>65</td><td>64</td><td></td><td></td><td>59</td><td>57</td><td>55</td><td>53</td></tr> <tr><td></td><td></td><td>50</td><td>49</td><td>48</td><td>46</td><td></td><td></td><td></td><td></td><td>39</td><td>37</td><td>35</td><td>33</td></tr> <tr><td>73</td><td></td><td></td><td>32</td><td></td><td>29</td><td></td><td></td><td></td><td></td><td>23</td><td>21</td><td></td><td></td></tr> <tr><td></td><td></td><td></td><td>15</td><td></td><td></td><td></td><td></td><td></td><td></td><td>7</td><td>6</td><td>5</td><td>4</td><td>3</td><td></td><td></td></tr> </table>							65	64			59	57	55	53			50	49	48	46					39	37	35	33	73			32		29					23	21						15							7	6	5	4	3																			
						65	64			59	57	55	53																																																																						
		50	49	48	46					39	37	35	33																																																																						
73			32		29					23	21																																																																								
			15							7	6	5	4	3																																																																					
AVAILABLE	NOT APPLICABLE	34566-5403	G	0	B	ST GRY	<table border="1"> <tr><td></td><td></td><td></td><td></td><td></td><td></td><td>65</td><td></td><td></td><td></td><td>59</td><td>58</td><td>57</td><td>56</td><td>55</td><td>53</td></tr> <tr><td></td><td></td><td>50</td><td>49</td><td>48</td><td>46</td><td>45</td><td></td><td></td><td></td><td>39</td><td>38</td><td>37</td><td></td><td>35</td><td>34</td><td>33</td></tr> <tr><td>73</td><td></td><td></td><td></td><td></td><td>29</td><td></td><td></td><td></td><td></td><td>23</td><td>22</td><td>21</td><td></td><td></td><td>18</td><td></td></tr> <tr><td></td><td></td><td></td><td>16</td><td>15</td><td>14</td><td></td><td></td><td></td><td></td><td>7</td><td>6</td><td>5</td><td>4</td><td>3</td><td></td><td></td></tr> </table>							65				59	58	57	56	55	53			50	49	48	46	45				39	38	37		35	34	33	73					29					23	22	21			18					16	15	14					7	6	5	4	3											
						65				59	58	57	56	55	53																																																																				
		50	49	48	46	45				39	38	37		35	34	33																																																																			
73					29					23	22	21			18																																																																				
			16	15	14					7	6	5	4	3																																																																					
AVAILABLE	NOT APPLICABLE	34566-5503	G	0	A	BLACK	<table border="1"> <tr><td>72</td><td>71</td><td>69</td><td>68</td><td>67</td><td>66</td><td>64</td><td>63</td><td>62</td><td></td><td>60</td><td>59</td><td></td><td></td><td></td><td></td><td></td><td>35</td><td>33</td></tr> <tr><td>52</td><td></td><td>49</td><td>48</td><td>46</td><td>44</td><td>43</td><td>42</td><td></td><td>40</td><td>39</td><td></td><td></td><td></td><td></td><td></td><td></td><td></td><td>17</td></tr> <tr><td>73</td><td></td><td></td><td>32</td><td></td><td>29</td><td>27</td><td>26</td><td></td><td>24</td><td>23</td><td></td><td></td><td></td><td></td><td></td><td></td><td></td><td></td></tr> <tr><td></td><td></td><td></td><td></td><td>14</td><td>13</td><td>12</td><td>11</td><td>10</td><td>9</td><td>8</td><td>7</td><td>6</td><td>5</td><td>4</td><td>3</td><td>2</td><td>1</td><td></td></tr> </table>	72	71	69	68	67	66	64	63	62		60	59						35	33	52		49	48	46	44	43	42		40	39								17	73			32		29	27	26		24	23													14	13	12	11	10	9	8	7	6	5	4	3	2	1	
72	71	69	68	67	66	64	63	62		60	59						35	33																																																																	
52		49	48	46	44	43	42		40	39								17																																																																	
73			32		29	27	26		24	23																																																																									
				14	13	12	11	10	9	8	7	6	5	4	3	2	1																																																																		
AVAILABLE	NOT APPLICABLE	34566-5603						SEE 34566-2503																																																																											
AVAILABLE	NOT APPLICABLE	34566-5703	G	0	B	ST GRY	<table border="1"> <tr><td></td><td></td><td></td><td>68</td><td></td><td></td><td></td><td></td><td></td><td></td><td>59</td><td>57</td><td>55</td><td>53</td></tr> <tr><td></td><td></td><td>49</td><td>48</td><td>46</td><td></td><td></td><td></td><td></td><td></td><td>39</td><td>37</td><td>35</td><td>33</td></tr> <tr><td>73</td><td></td><td></td><td></td><td>29</td><td></td><td></td><td></td><td></td><td></td><td>23</td><td>21</td><td></td><td>18</td><td>17</td></tr> <tr><td></td><td></td><td></td><td></td><td></td><td></td><td>12</td><td>11</td><td>10</td><td></td><td>7</td><td></td><td></td><td></td><td></td><td></td><td></td></tr> </table>				68							59	57	55	53			49	48	46						39	37	35	33	73				29						23	21		18	17							12	11	10		7																						
			68							59	57	55	53																																																																						
		49	48	46						39	37	35	33																																																																						
73				29						23	21		18	17																																																																					
						12	11	10		7																																																																									
AVAILABLE	NOT APPLICABLE	34566-5803	G	0	B	ST GRY	<table border="1"> <tr><td></td><td></td><td>49</td><td>48</td><td>47</td><td></td><td>65</td><td></td><td></td><td></td><td>59</td><td>57</td><td>55</td><td>53</td></tr> <tr><td></td><td></td><td></td><td></td><td></td><td>29</td><td></td><td></td><td></td><td></td><td>39</td><td>37</td><td>35</td><td>33</td></tr> <tr><td>73</td><td></td><td></td><td></td><td></td><td>12</td><td></td><td></td><td></td><td></td><td>23</td><td>21</td><td></td><td>17</td></tr> <tr><td></td><td></td><td></td><td></td><td></td><td></td><td></td><td></td><td></td><td></td><td>7</td><td></td><td></td><td></td><td></td><td></td></tr> </table>			49	48	47		65				59	57	55	53						29					39	37	35	33	73					12					23	21		17											7																							
		49	48	47		65				59	57	55	53																																																																						
					29					39	37	35	33																																																																						
73					12					23	21		17																																																																						
										7																																																																									
AVAILABLE	NOT APPLICABLE	34566-5903	G	0	A	BLACK	<table border="1"> <tr><td>72</td><td>71</td><td>69</td><td>68</td><td>67</td><td>66</td><td>64</td><td>63</td><td>62</td><td></td><td>59</td><td></td><td></td><td></td><td></td><td></td><td></td><td>35</td><td>33</td></tr> <tr><td></td><td></td><td></td><td>48</td><td></td><td></td><td>44</td><td>43</td><td>42</td><td></td><td>39</td><td></td><td></td><td></td><td></td><td></td><td></td><td></td><td>17</td></tr> <tr><td>73</td><td></td><td></td><td>32</td><td></td><td>29</td><td>27</td><td></td><td></td><td></td><td>23</td><td></td><td></td><td></td><td></td><td></td><td></td><td></td><td></td></tr> <tr><td></td><td></td><td></td><td></td><td></td><td>13</td><td>12</td><td>11</td><td>9</td><td>8</td><td></td><td></td><td>5</td><td>4</td><td>3</td><td>2</td><td>1</td><td></td><td></td></tr> </table>	72	71	69	68	67	66	64	63	62		59							35	33				48			44	43	42		39								17	73			32		29	27				23														13	12	11	9	8			5	4	3	2	1		
72	71	69	68	67	66	64	63	62		59							35	33																																																																	
			48			44	43	42		39								17																																																																	
73			32		29	27				23																																																																									
					13	12	11	9	8			5	4	3	2	1																																																																			
SEE NEXT PAGE FOR ADDITIONAL NUMBERS																																																																																			

ENTER DESCRIPTION IEC NO: UAU2014-0376 DRAWN BY: 2013/09/05 CHKD: 2013/09/06 APPR: VIKASHY REV: 05	QUALITY SYMBOLS ∇=0 ∇=0 ∇=0	GENERAL TOLERANCES (UNLESS SPECIFIED) mm INCH 4 PLACES ± --- ± --- 3 PLACES ± --- ± --- 2 PLACES ± --- ± --- 1 PLACE ± --- ± --- 0 PLACE ± --- ± --- ANGULAR ± --- ° DRAFT WHERE APPLICABLE MUST REMAIN WITHIN DIMENSIONS	DIMENSION STYLE MM ONLY DRAWN BY: SKRAJENDRANA DATE: 2011/02/14 CHECKED BY: MVANSLAMBROU DATE: 2011/02/14 APPROVED BY:	SCALE: METRIC DESIGN UNITS: METRIC THIRD ANGLE PROJECTION	TITLE: MX123 66/73/80CKT HRNS CONN ASSY molex DOCUMENT NO: SD-34566-001 SHEET NO: 9 OF 68

19 18 17 16 15 14 13 12 11 10 9 8 7 6 5 4 3 2 1

STATUS	GM PART #	MATERIAL #	PART/MATERIAL REVISION	WIRE DRESS OPTION	KEY OPTION	COLOR (TPA)	NUMBERS INDICATE CAVITIES OPEN FOR CIRCUITS																						
AVAILABLE	NOT APPLICABLE	34566-6003	G	0	B	ST GRAY												59	57	55	53								
									49	48	47							39	37	35	33								
							73											23	21										
																	7												
AVAILABLE	NOT APPLICABLE	34566-6103	G	0	B	ST GRAY													59	57	55	53							
									49	48	47							42	39	37	35	33							
							73											23	21										
																	9	7											
AVAILABLE	NOT APPLICABLE	34566-6203	G	0	A	BLACK		71	70	69	68			65	64	63		61	59	57	56								
							52	51	50	49		47							41		38	37	36	34	33				
							73													24	23			20	19	18			
																											1		
AVAILABLE	NOT APPLICABLE	34566-6303	G	0	A	BLACK		71	70	69	68			65	64	63		61	59	57	56								
							52	51	50	49		47							41		38	37	36	34	33				
							73														24	23			20	19	18		
																											2	1	
AVAILABLE	NOT APPLICABLE	34566-6403	G	0	A	BLACK		71		69	68			65	64	63		61	59	58	56								
							52		50	49		47							41		38	37	36	34	33				
							73														24	23			20	19	18		
																												1	
AVAILABLE	NOT APPLICABLE	34566-6503	G	0	A	BLACK		71		69	68			65	64	63		61	59	58	56								
							52		50	49		47							41		38	37	36	34	33				
							73															24	23			20	19	18	
																												2	1
AVAILABLE	NOT APPLICABLE	34566-6603	G	0	H	ST GRAY		79	78	77	76	75	74	73	72	71	70	69	68		66	65	64	63	61				
							60	59	58	57	56			53	52	50									44	43	41		
							40	39	38	37		35	34	33	32	30	29		27	26							22	21	
							20	19	18	17	16			14	13	12	11	10	9	8	6	5					3	2	
AVAILABLE	NOT APPLICABLE	34566-6703	G	0	H	ST GRAY		79	78	77	76	75	74	73	72	71	70	69	68		66	65	64	63	61				
							60	59	58	57	56			53	50										44	43	41		
							40	39	38	37		35	34	33	32	30	29		27	26							22	21	
							20	19	18	17	16			14	13	12	11	10	9	8	6	5					3	2	

SEE NEXT PAGE FOR ADDITIONAL NUMBERS

ENTER DESCRIPTION IEC NO: UAU2014-0376 DRAWN BY: 2013/09/05 CHKD: 2013/09/06 APPR: IKOSHY REV: 05	QUALITY SYMBOLS ▽=0 ▽=0 ▽=0	GENERAL TOLERANCES (UNLESS SPECIFIED) 4 PLACES ±--- ±--- 3 PLACES ±--- ±--- 2 PLACES ±--- ±--- 1 PLACE ±--- ±--- 0 PLACE ±--- ±---	DIMENSION STYLE MM ONLY	SCALE DESIGN UNITS METRIC	THIRD ANGLE PROJECTION	
	ANGULAR ±---°	DRAFT WHERE APPLICABLE MUST REMAIN WITHIN DIMENSIONS	DRAWN BY: SKRAJENDRANA 2011/02/14 CHECKED BY: MYANSLAMBROU 2011/02/14 APPROVED BY:	TITLE: MX123 66/73/80CKT HRNS CONN ASSY	MATERIAL NO.: SD-34566-001 DOCUMENT NO.:	SHEET NO. 10 OF 68
	SEE BOM TABLE		THIS DRAWING CONTAINS INFORMATION THAT IS PROPRIETARY TO MOLEX INCORPORATED AND SHOULD NOT BE USED WITHOUT WRITTEN PERMISSION			

STATUS	GM PART #	MATERIAL #	PART/MATERIAL REVISION	WIRE DRESS OPTION	KEY OPTION	COLOR (TPA)	NUMBERS INDICATE CAVITIES OPEN FOR CIRCUITS																																																																																												
AVAILABLE	NOT APPLICABLE	34566-6803	G	0	B	ST GRY	<table border="1"> <tr><td></td><td></td><td></td><td></td><td></td><td></td><td></td><td>65</td><td></td><td></td><td></td><td></td><td></td><td></td><td></td><td>59</td><td>57</td><td>55</td><td>53</td></tr> <tr><td></td><td></td><td></td><td>49</td><td>48</td><td>46</td><td></td><td>44</td><td></td><td></td><td></td><td></td><td></td><td></td><td></td><td>39</td><td>37</td><td>35</td><td>33</td></tr> <tr><td></td><td></td><td></td><td colspan="2">73</td><td></td><td></td><td>29</td><td>28</td><td></td><td></td><td></td><td></td><td></td><td></td><td>23</td><td>21</td><td></td><td></td></tr> <tr><td></td><td></td><td></td><td></td><td></td><td></td><td></td><td></td><td></td><td></td><td></td><td></td><td></td><td></td><td></td><td>7</td><td></td><td></td><td></td></tr> </table>									65								59	57	55	53				49	48	46		44								39	37	35	33				73				29	28							23	21																		7																		
							65								59	57	55	53																																																																																	
			49	48	46		44								39	37	35	33																																																																																	
			73				29	28							23	21																																																																																			
															7																																																																																				
AVAILABLE	NOT APPLICABLE	34566-6903	G	0	B	ST GRY	<table border="1"> <tr><td></td><td></td><td></td><td></td><td></td><td></td><td></td><td>64</td><td></td><td></td><td></td><td></td><td></td><td></td><td></td><td>59</td><td>57</td><td>55</td><td>53</td></tr> <tr><td></td><td></td><td></td><td>49</td><td>48</td><td>46</td><td></td><td></td><td></td><td></td><td></td><td></td><td></td><td></td><td></td><td>39</td><td>37</td><td>35</td><td>33</td></tr> <tr><td></td><td></td><td></td><td colspan="2">73</td><td></td><td></td><td></td><td>29</td><td></td><td></td><td></td><td></td><td></td><td></td><td>23</td><td>21</td><td></td><td>18</td></tr> <tr><td></td><td></td><td></td><td></td><td></td><td></td><td></td><td></td><td></td><td></td><td></td><td></td><td></td><td></td><td></td><td>7</td><td></td><td></td><td></td></tr> </table>									64								59	57	55	53				49	48	46										39	37	35	33				73					29							23	21		18																7																		
							64								59	57	55	53																																																																																	
			49	48	46										39	37	35	33																																																																																	
			73					29							23	21		18																																																																																	
															7																																																																																				
AVAILABLE	NOT APPLICABLE	34566-7003	G	0	B	ST GRY	<table border="1"> <tr><td></td><td></td><td></td><td></td><td></td><td></td><td></td><td>67</td><td>66</td><td></td><td></td><td></td><td></td><td></td><td></td><td>59</td><td>57</td><td>56</td><td>55</td><td>53</td></tr> <tr><td></td><td></td><td></td><td>50</td><td>49</td><td>48</td><td>47</td><td></td><td></td><td></td><td></td><td></td><td></td><td></td><td></td><td>39</td><td>37</td><td>36</td><td>35</td><td>33</td></tr> <tr><td></td><td></td><td></td><td colspan="2">73</td><td></td><td></td><td></td><td></td><td>29</td><td></td><td></td><td></td><td></td><td></td><td>23</td><td>21</td><td></td><td></td><td>18</td></tr> <tr><td></td><td></td><td></td><td></td><td></td><td></td><td></td><td></td><td></td><td>15</td><td>13</td><td>12</td><td></td><td></td><td></td><td>8</td><td>7</td><td>6</td><td>5</td><td>4</td><td>3</td><td>2</td><td>1</td></tr> </table>									67	66							59	57	56	55	53				50	49	48	47									39	37	36	35	33				73						29						23	21			18										15	13	12				8	7	6	5	4	3	2	1								
							67	66							59	57	56	55	53																																																																																
			50	49	48	47									39	37	36	35	33																																																																																
			73						29						23	21			18																																																																																
									15	13	12				8	7	6	5	4	3	2	1																																																																													
AVAILABLE	NOT APPLICABLE	34566-7103	G	0	A	BLACK	<table border="1"> <tr><td>72</td><td>71</td><td>70</td><td>69</td><td>68</td><td>67</td><td>66</td><td></td><td>64</td><td>63</td><td>62</td><td></td><td>60</td><td>59</td><td></td><td></td><td></td><td>55</td><td>54</td><td>53</td></tr> <tr><td>52</td><td></td><td></td><td>49</td><td>48</td><td></td><td></td><td></td><td>44</td><td>43</td><td>42</td><td></td><td>40</td><td>39</td><td></td><td></td><td></td><td></td><td>35</td><td>34</td><td>33</td></tr> <tr><td></td><td></td><td></td><td colspan="2">73</td><td></td><td></td><td></td><td></td><td>29</td><td>28</td><td>27</td><td></td><td>24</td><td>23</td><td></td><td></td><td></td><td></td><td>19</td><td>18</td><td>17</td></tr> <tr><td></td><td></td><td></td><td></td><td></td><td></td><td></td><td></td><td></td><td>16</td><td></td><td></td><td>13</td><td>12</td><td>11</td><td></td><td>9</td><td>8</td><td>7</td><td>6</td><td>5</td><td>4</td><td>3</td><td>2</td><td>1</td></tr> </table>		72	71	70	69	68	67	66		64	63	62		60	59				55	54	53	52			49	48				44	43	42		40	39					35	34	33				73						29	28	27		24	23					19	18	17										16			13	12	11		9	8	7	6	5	4	3	2	1			
72	71	70	69	68	67	66		64	63	62		60	59				55	54	53																																																																																
52			49	48				44	43	42		40	39					35	34	33																																																																															
			73						29	28	27		24	23					19	18	17																																																																														
									16			13	12	11		9	8	7	6	5	4	3	2	1																																																																											
AVAILABLE	NOT APPLICABLE	34566-7203	G	0	B	ST GRY	<table border="1"> <tr><td>72</td><td>71</td><td>70</td><td>69</td><td>68</td><td>67</td><td>66</td><td></td><td>65</td><td>64</td><td>63</td><td>62</td><td></td><td>60</td><td>59</td><td></td><td></td><td></td><td>55</td><td>54</td><td>53</td></tr> <tr><td>52</td><td></td><td></td><td>49</td><td>48</td><td></td><td></td><td></td><td>44</td><td>43</td><td>42</td><td></td><td></td><td>39</td><td></td><td></td><td></td><td></td><td></td><td>35</td><td>34</td><td>33</td></tr> <tr><td></td><td></td><td></td><td colspan="2">73</td><td></td><td></td><td></td><td></td><td>29</td><td>27</td><td></td><td></td><td>24</td><td>23</td><td></td><td></td><td></td><td></td><td>20</td><td>19</td><td>18</td><td>17</td></tr> <tr><td></td><td></td><td></td><td></td><td></td><td></td><td></td><td></td><td></td><td>16</td><td></td><td></td><td>13</td><td>12</td><td>11</td><td></td><td>9</td><td>8</td><td>7</td><td>6</td><td>5</td><td>4</td><td>3</td><td>2</td><td>1</td></tr> </table>		72	71	70	69	68	67	66		65	64	63	62		60	59				55	54	53	52			49	48				44	43	42			39						35	34	33				73						29	27			24	23					20	19	18	17										16			13	12	11		9	8	7	6	5	4	3	2	1
72	71	70	69	68	67	66		65	64	63	62		60	59				55	54	53																																																																															
52			49	48				44	43	42			39						35	34	33																																																																														
			73						29	27			24	23					20	19	18	17																																																																													
									16			13	12	11		9	8	7	6	5	4	3	2	1																																																																											
AVAILABLE	NOT APPLICABLE	34566-7303	G	0	B	ST GRY	<table border="1"> <tr><td></td><td></td><td></td><td>69</td><td>68</td><td></td><td>66</td><td></td><td></td><td></td><td></td><td></td><td></td><td></td><td>59</td><td></td><td></td><td></td><td>55</td><td>53</td></tr> <tr><td></td><td></td><td></td><td>49</td><td>48</td><td></td><td>46</td><td></td><td></td><td>44</td><td></td><td></td><td></td><td></td><td>39</td><td></td><td></td><td></td><td>37</td><td>35</td><td>33</td></tr> <tr><td></td><td></td><td></td><td colspan="2">73</td><td></td><td></td><td></td><td></td><td>29</td><td>28</td><td></td><td></td><td></td><td>23</td><td></td><td></td><td></td><td>21</td><td></td><td>18</td><td>17</td></tr> <tr><td></td><td></td><td></td><td></td><td></td><td></td><td></td><td></td><td></td><td></td><td></td><td></td><td></td><td></td><td>7</td><td></td><td></td><td></td><td></td><td></td><td></td><td></td><td></td><td></td><td></td></tr> </table>					69	68		66								59				55	53				49	48		46			44					39				37	35	33				73						29	28				23				21		18	17															7													
			69	68		66								59				55	53																																																																																
			49	48		46			44					39				37	35	33																																																																															
			73						29	28				23				21		18	17																																																																														
														7																																																																																					
AVAILABLE	NOT APPLICABLE	34566-7403	G	0	B	ST GRY	<table border="1"> <tr><td></td><td></td><td></td><td></td><td></td><td></td><td></td><td></td><td></td><td></td><td></td><td></td><td></td><td></td><td></td><td>59</td><td></td><td></td><td>57</td><td>55</td><td>53</td></tr> <tr><td></td><td></td><td></td><td>50</td><td>49</td><td>48</td><td></td><td>46</td><td></td><td></td><td></td><td></td><td></td><td></td><td></td><td>39</td><td></td><td></td><td>37</td><td>35</td><td>33</td></tr> <tr><td></td><td></td><td></td><td colspan="2">73</td><td></td><td></td><td></td><td></td><td>29</td><td></td><td></td><td></td><td></td><td></td><td>23</td><td></td><td></td><td>21</td><td></td><td></td><td>18</td><td>17</td></tr> <tr><td></td><td></td><td></td><td></td><td></td><td></td><td></td><td></td><td></td><td></td><td></td><td></td><td></td><td></td><td></td><td>7</td><td></td><td></td><td>6</td><td>5</td><td>4</td><td>3</td><td></td><td></td></tr> </table>																	59			57	55	53				50	49	48		46								39			37	35	33				73						29						23			21			18	17																7			6	5	4	3				
															59			57	55	53																																																																															
			50	49	48		46								39			37	35	33																																																																															
			73						29						23			21			18	17																																																																													
															7			6	5	4	3																																																																														
AVAILABLE	NOT APPLICABLE	34566-7503	G	0	A	BLACK	<table border="1"> <tr><td>72</td><td>71</td><td>70</td><td>69</td><td>68</td><td>67</td><td>66</td><td></td><td>64</td><td>63</td><td>62</td><td></td><td>60</td><td>59</td><td>58</td><td>57</td><td></td><td>56</td><td>55</td><td>54</td><td>53</td></tr> <tr><td>52</td><td>51</td><td>50</td><td>49</td><td>48</td><td>47</td><td>46</td><td></td><td>44</td><td>43</td><td>42</td><td></td><td>40</td><td>39</td><td>38</td><td>37</td><td></td><td>36</td><td>35</td><td>34</td><td>33</td></tr> <tr><td></td><td></td><td></td><td colspan="2">73</td><td></td><td></td><td></td><td></td><td>32</td><td>31</td><td>30</td><td>29</td><td>28</td><td>27</td><td></td><td>24</td><td>23</td><td>22</td><td>21</td><td>20</td><td>19</td><td>18</td><td>17</td></tr> <tr><td></td><td></td><td></td><td></td><td></td><td></td><td></td><td></td><td></td><td>16</td><td>15</td><td>14</td><td>13</td><td>12</td><td>11</td><td></td><td>9</td><td>8</td><td>7</td><td>6</td><td>5</td><td>4</td><td>3</td><td>2</td><td>1</td></tr> </table>		72	71	70	69	68	67	66		64	63	62		60	59	58	57		56	55	54	53	52	51	50	49	48	47	46		44	43	42		40	39	38	37		36	35	34	33				73						32	31	30	29	28	27		24	23	22	21	20	19	18	17										16	15	14	13	12	11		9	8	7	6	5	4	3	2	1
72	71	70	69	68	67	66		64	63	62		60	59	58	57		56	55	54	53																																																																															
52	51	50	49	48	47	46		44	43	42		40	39	38	37		36	35	34	33																																																																															
			73						32	31	30	29	28	27		24	23	22	21	20	19	18	17																																																																												
									16	15	14	13	12	11		9	8	7	6	5	4	3	2	1																																																																											

SEE NEXT PAGE FOR ADDITIONAL NUMBERS

ENTER DESCRIPTION IEC NO: UAU2014-0376 DRAWN BY: CHKD CHECKED BY: APPR:IKOSHY 2013/09/05 2013/09/06 55	QUALITY SYMBOLS ∇=0 ∇=0 ∇=0	GENERAL TOLERANCES (UNLESS SPECIFIED) DIMENSION STYLE UNLESS SPECIFIED MM ONLY	DIMENSION STYLE SCALE DESIGN UNITS METRIC	THIRD ANGLE PROJECTION DATE DATE DATE	TITLE MX123 66/73/80CKT HRNS CONN ASSY	MATERIAL NO. DOCUMENT NO. SD-34566-001	SHEET NO. 11 OF 68	
	ANGULAR ±---° DRAFT WHERE APPLICABLE MUST REMAIN WITHIN DIMENSIONS	SEE BOM TABLE	THIS DRAWING CONTAINS INFORMATION THAT IS PROPRIETARY TO MOLEX INCORPORATED AND SHOULD NOT BE USED WITHOUT WRITTEN PERMISSION					

STATUS	GM PART #	MATERIAL #	PART/MATERIAL REVISION	WIRE DRESS OPTION	KEY OPTION	COLOR (TPA)	NUMBERS INDICATE CAVITIES OPEN FOR CIRCUITS																																																																								
AVAILABLE	NOT APPLICABLE	34566-7603	G	0	B	ST GRAY	<table border="1"> <tr><td></td><td></td><td>69</td><td>68</td><td>66</td><td></td><td></td><td></td><td></td><td></td><td>59</td><td>57</td><td>55</td><td>53</td></tr> <tr><td></td><td></td><td>49</td><td>48</td><td>46</td><td>44</td><td></td><td></td><td></td><td></td><td>39</td><td>37</td><td>35</td><td>33</td></tr> <tr><td>73</td><td></td><td></td><td></td><td></td><td>29</td><td>28</td><td></td><td></td><td></td><td>23</td><td>21</td><td></td><td>18</td><td>17</td></tr> <tr><td></td><td></td><td></td><td></td><td></td><td>12</td><td>11</td><td>10</td><td></td><td></td><td>7</td><td></td><td></td><td></td><td></td></tr> </table>			69	68	66						59	57	55	53			49	48	46	44					39	37	35	33	73					29	28				23	21		18	17						12	11	10			7																		
		69	68	66						59	57	55	53																																																																		
		49	48	46	44					39	37	35	33																																																																		
73					29	28				23	21		18	17																																																																	
					12	11	10			7																																																																					
AVAILABLE	NOT APPLICABLE	34566-7703	G	0	A	BLACK	<table border="1"> <tr><td>72</td><td>71</td><td>70</td><td>69</td><td>68</td><td>67</td><td>66</td><td>64</td><td>63</td><td>62</td><td>60</td><td>59</td><td></td><td></td><td>55</td><td>54</td><td>53</td></tr> <tr><td>52</td><td></td><td>49</td><td>48</td><td></td><td></td><td></td><td>44</td><td>43</td><td>42</td><td>40</td><td>39</td><td></td><td></td><td>35</td><td>34</td><td>33</td></tr> <tr><td></td><td></td><td></td><td>32</td><td></td><td></td><td>29</td><td></td><td>27</td><td></td><td>24</td><td>23</td><td></td><td></td><td>19</td><td>18</td><td>17</td></tr> <tr><td>73</td><td></td><td></td><td>16</td><td></td><td></td><td>13</td><td>12</td><td>11</td><td></td><td>9</td><td>8</td><td>7</td><td>6</td><td>5</td><td>4</td><td>3</td><td>2</td><td>1</td></tr> </table>	72	71	70	69	68	67	66	64	63	62	60	59			55	54	53	52		49	48				44	43	42	40	39			35	34	33				32			29		27		24	23			19	18	17	73			16			13	12	11		9	8	7	6	5	4	3	2	1		
72	71	70	69	68	67	66	64	63	62	60	59			55	54	53																																																															
52		49	48				44	43	42	40	39			35	34	33																																																															
			32			29		27		24	23			19	18	17																																																															
73			16			13	12	11		9	8	7	6	5	4	3	2	1																																																													
AVAILABLE	NOT APPLICABLE	34566-7803	G	0	A	BLACK	<table border="1"> <tr><td>72</td><td>71</td><td>70</td><td></td><td>68</td><td></td><td>66</td><td>64</td><td>63</td><td>62</td><td>61</td><td>60</td><td>59</td><td></td><td></td><td>55</td><td>54</td><td>53</td></tr> <tr><td>52</td><td></td><td>49</td><td>48</td><td></td><td>46</td><td></td><td>44</td><td>43</td><td>42</td><td>40</td><td>39</td><td></td><td></td><td>35</td><td>34</td><td>33</td><td></td></tr> <tr><td></td><td></td><td></td><td>32</td><td></td><td></td><td>29</td><td>28</td><td>27</td><td></td><td>24</td><td>23</td><td></td><td></td><td>19</td><td>18</td><td>17</td><td></td></tr> <tr><td>73</td><td></td><td></td><td>16</td><td></td><td>14</td><td>13</td><td>12</td><td>11</td><td></td><td>9</td><td>8</td><td>7</td><td>6</td><td></td><td>3</td><td>2</td><td>1</td></tr> </table>	72	71	70		68		66	64	63	62	61	60	59			55	54	53	52		49	48		46		44	43	42	40	39			35	34	33					32			29	28	27		24	23			19	18	17		73			16		14	13	12	11		9	8	7	6		3	2	1
72	71	70		68		66	64	63	62	61	60	59			55	54	53																																																														
52		49	48		46		44	43	42	40	39			35	34	33																																																															
			32			29	28	27		24	23			19	18	17																																																															
73			16		14	13	12	11		9	8	7	6		3	2	1																																																														
AVAILABLE	NOT APPLICABLE	34566-7903	G	0	B	ST GRAY	<table border="1"> <tr><td></td><td></td><td></td><td></td><td></td><td></td><td></td><td>64</td><td></td><td>61</td><td>59</td><td>57</td><td>55</td><td>53</td></tr> <tr><td></td><td></td><td></td><td></td><td></td><td></td><td></td><td></td><td>42</td><td></td><td>39</td><td></td><td>35</td><td>33</td></tr> <tr><td>73</td><td></td><td></td><td></td><td></td><td></td><td></td><td></td><td></td><td></td><td>23</td><td></td><td>20</td><td>19</td></tr> <tr><td></td><td></td><td></td><td></td><td></td><td>15</td><td></td><td></td><td></td><td></td><td></td><td></td><td>4</td><td>3</td><td>2</td><td>1</td><td></td></tr> </table>								64		61	59	57	55	53									42		39		35	33	73										23		20	19						15							4	3	2	1														
							64		61	59	57	55	53																																																																		
								42		39		35	33																																																																		
73										23		20	19																																																																		
					15							4	3	2	1																																																																
AVAILABLE	NOT APPLICABLE	34566-8003	G	0	A	BLACK	<table border="1"> <tr><td></td><td></td><td>69</td><td>68</td><td></td><td></td><td>65</td><td>64</td><td>63</td><td>61</td><td>60</td><td>59</td><td>58</td><td>56</td><td></td><td></td><td></td><td></td></tr> <tr><td>52</td><td>50</td><td>49</td><td>48</td><td>47</td><td></td><td></td><td></td><td></td><td>41</td><td></td><td></td><td>38</td><td>37</td><td>36</td><td></td><td>34</td><td>33</td></tr> <tr><td></td><td></td><td></td><td>32</td><td>31</td><td>30</td><td>29</td><td>28</td><td>27</td><td></td><td>24</td><td>23</td><td></td><td></td><td>20</td><td>19</td><td>18</td><td>17</td></tr> <tr><td>73</td><td></td><td></td><td>16</td><td></td><td></td><td>13</td><td>12</td><td>11</td><td>10</td><td>9</td><td></td><td></td><td></td><td></td><td></td><td></td><td>1</td></tr> </table>			69	68			65	64	63	61	60	59	58	56					52	50	49	48	47					41			38	37	36		34	33				32	31	30	29	28	27		24	23			20	19	18	17	73			16			13	12	11	10	9							1
		69	68			65	64	63	61	60	59	58	56																																																																		
52	50	49	48	47					41			38	37	36		34	33																																																														
			32	31	30	29	28	27		24	23			20	19	18	17																																																														
73			16			13	12	11	10	9							1																																																														
AVAILABLE	NOT APPLICABLE	34566-8103	G	0	H	ST GRAY	<table border="1"> <tr><td></td><td></td><td>78</td><td></td><td></td><td></td><td></td><td>72</td><td>71</td><td>70</td><td>69</td><td>68</td><td>66</td><td>65</td><td>64</td><td>63</td><td>61</td><td></td></tr> <tr><td>60</td><td>59</td><td>58</td><td>57</td><td>56</td><td></td><td>53</td><td>52</td><td>50</td><td></td><td></td><td></td><td></td><td></td><td>44</td><td>43</td><td>41</td><td></td></tr> <tr><td>40</td><td></td><td></td><td>37</td><td>35</td><td>34</td><td>33</td><td>32</td><td>30</td><td>29</td><td>27</td><td>26</td><td></td><td></td><td>24</td><td>22</td><td>21</td><td></td></tr> <tr><td>20</td><td>19</td><td>18</td><td>17</td><td>16</td><td></td><td></td><td>13</td><td>12</td><td></td><td></td><td>8</td><td>6</td><td>5</td><td></td><td>3</td><td>2</td><td>1</td></tr> </table>			78					72	71	70	69	68	66	65	64	63	61		60	59	58	57	56		53	52	50						44	43	41		40			37	35	34	33	32	30	29	27	26			24	22	21		20	19	18	17	16			13	12			8	6	5		3	2	1
		78					72	71	70	69	68	66	65	64	63	61																																																															
60	59	58	57	56		53	52	50						44	43	41																																																															
40			37	35	34	33	32	30	29	27	26			24	22	21																																																															
20	19	18	17	16			13	12			8	6	5		3	2	1																																																														
AVAILABLE	NOT APPLICABLE	34566-8203	G	0	A	BLACK	<table border="1"> <tr><td></td><td></td><td>70</td><td></td><td></td><td>67</td><td>66</td><td></td><td></td><td></td><td></td><td></td><td>58</td><td>56</td><td>55</td><td>54</td><td></td></tr> <tr><td></td><td></td><td></td><td></td><td></td><td>47</td><td></td><td>44</td><td>43</td><td>42</td><td>41</td><td>39</td><td></td><td>37</td><td>36</td><td>34</td><td></td></tr> <tr><td>73</td><td></td><td></td><td></td><td></td><td>31</td><td>30</td><td></td><td>27</td><td>25</td><td>24</td><td></td><td></td><td>21</td><td>20</td><td>19</td><td>18</td></tr> <tr><td></td><td></td><td></td><td></td><td></td><td></td><td></td><td>13</td><td></td><td></td><td></td><td></td><td>6</td><td>5</td><td>4</td><td>3</td><td>2</td><td>1</td></tr> </table>			70			67	66						58	56	55	54							47		44	43	42	41	39		37	36	34		73					31	30		27	25	24			21	20	19	18								13					6	5	4	3	2	1			
		70			67	66						58	56	55	54																																																																
					47		44	43	42	41	39		37	36	34																																																																
73					31	30		27	25	24			21	20	19	18																																																															
							13					6	5	4	3	2	1																																																														
AVAILABLE	NOT APPLICABLE	34566-8303	G	0	A	BLACK	<table border="1"> <tr><td>72</td><td>71</td><td>69</td><td>68</td><td>67</td><td>66</td><td>64</td><td>63</td><td>62</td><td></td><td>59</td><td>58</td><td>57</td><td>56</td><td></td><td>54</td><td>53</td></tr> <tr><td>52</td><td>51</td><td>50</td><td>49</td><td>48</td><td>47</td><td>46</td><td>44</td><td>43</td><td>42</td><td></td><td>39</td><td>38</td><td>37</td><td>36</td><td>35</td><td>34</td><td>33</td></tr> <tr><td></td><td></td><td></td><td>32</td><td>31</td><td>30</td><td>29</td><td></td><td>27</td><td></td><td>24</td><td>23</td><td>22</td><td>21</td><td>20</td><td>19</td><td>17</td><td></td></tr> <tr><td>73</td><td></td><td></td><td>15</td><td>14</td><td>13</td><td>12</td><td>11</td><td></td><td>9</td><td>8</td><td>7</td><td>6</td><td>5</td><td>4</td><td>3</td><td>2</td><td>1</td></tr> </table>	72	71	69	68	67	66	64	63	62		59	58	57	56		54	53	52	51	50	49	48	47	46	44	43	42		39	38	37	36	35	34	33				32	31	30	29		27		24	23	22	21	20	19	17		73			15	14	13	12	11		9	8	7	6	5	4	3	2	1	
72	71	69	68	67	66	64	63	62		59	58	57	56		54	53																																																															
52	51	50	49	48	47	46	44	43	42		39	38	37	36	35	34	33																																																														
			32	31	30	29		27		24	23	22	21	20	19	17																																																															
73			15	14	13	12	11		9	8	7	6	5	4	3	2	1																																																														

SEE NEXT PAGE FOR ADDITIONAL NUMBERS

ENTER DESCRIPTION ELEC NO: UAU2014-0376 DRAWN BY: DRINKATE CHKD: APPR:KOSHY 2013/09/05 2013/09/06 REV: 05	QUALITY SYMBOLS ∇=0 ∇=0 ∇=0	GENERAL TOLERANCES (UNLESS SPECIFIED) mm INCH 4 PLACES ± --- ± --- 3 PLACES ± --- ± --- 2 PLACES ± --- ± --- 1 PLACE ± --- ± --- 0 PLACE ± --- ± ---	DIMENSION STYLE MM ONLY	SCALE DESIGN UNITS METRIC	THIRD ANGLE PROJECTION
	DRAWN BY: SKRAJENDRANA 2011/02/14 CHECKED BY: MYANSLAMBROU 2011/02/14 APPROVED BY:		TITLE MX123 66/73/80CKT HRNS CONN ASSY		MATERIAL NO. DOCUMENT NO. SD-34566-001
	ANGULAR ± ---° DRAFT WHERE APPLICABLE MUST REMAIN WITHIN DIMENSIONS		SEE BOM TABLE		
	THIS DRAWING CONTAINS INFORMATION THAT IS PROPRIETARY TO MOLEX INCORPORATED AND SHOULD NOT BE USED WITHOUT WRITTEN PERMISSION				

STATUS	GM PART #	MATERIAL #	PART/MATERIAL REVISION	WIRE DRESS OPTION	KEY OPTION	COLOR (TPA)	NUMBERS INDICATE CAVITIES OPEN FOR CIRCUITS																																																																											
AVAILABLE	NOT APPLICABLE	34566-9203	G	0	A	BLACK	<table border="1"> <tr><td>72</td><td>71</td><td>70</td><td>69</td><td>68</td><td>67</td><td>66</td><td>64</td><td>63</td><td>62</td><td>60</td><td>59</td><td></td><td></td><td>55</td><td>54</td><td>53</td></tr> <tr><td>52</td><td></td><td></td><td>49</td><td>48</td><td></td><td></td><td>44</td><td>43</td><td>42</td><td>40</td><td>39</td><td>38</td><td></td><td>35</td><td>34</td><td>33</td></tr> <tr><td></td><td></td><td>73</td><td></td><td></td><td></td><td>30</td><td>29</td><td>28</td><td>27</td><td>24</td><td>23</td><td></td><td></td><td>19</td><td>18</td><td>17</td></tr> <tr><td></td><td></td><td></td><td>16</td><td></td><td></td><td>13</td><td>12</td><td>11</td><td></td><td>9</td><td>8</td><td>7</td><td>6</td><td>5</td><td>4</td><td>3</td><td>2</td><td>1</td></tr> </table>	72	71	70	69	68	67	66	64	63	62	60	59			55	54	53	52			49	48			44	43	42	40	39	38		35	34	33			73				30	29	28	27	24	23			19	18	17				16			13	12	11		9	8	7	6	5	4	3	2	1					
72	71	70	69	68	67	66	64	63	62	60	59			55	54	53																																																																		
52			49	48			44	43	42	40	39	38		35	34	33																																																																		
		73				30	29	28	27	24	23			19	18	17																																																																		
			16			13	12	11		9	8	7	6	5	4	3	2	1																																																																
AVAILABLE	NOT APPLICABLE	34566-9303	G	0	A	BLACK	<table border="1"> <tr><td>72</td><td>71</td><td></td><td>69</td><td>68</td><td>67</td><td>66</td><td>64</td><td>63</td><td>62</td><td></td><td>59</td><td>58</td><td>57</td><td>56</td><td>55</td><td>54</td><td>53</td></tr> <tr><td>52</td><td>51</td><td>50</td><td>49</td><td>48</td><td>47</td><td>46</td><td>44</td><td>43</td><td>42</td><td></td><td>39</td><td>38</td><td>37</td><td>36</td><td>35</td><td>34</td><td>33</td></tr> <tr><td></td><td></td><td>73</td><td></td><td>32</td><td>31</td><td>30</td><td>29</td><td>27</td><td></td><td>24</td><td>23</td><td>22</td><td>21</td><td>20</td><td>19</td><td>17</td><td></td></tr> <tr><td></td><td></td><td></td><td>15</td><td>14</td><td>13</td><td>12</td><td>11</td><td></td><td></td><td>9</td><td>8</td><td>7</td><td>6</td><td>5</td><td>4</td><td>3</td><td>2</td><td>1</td></tr> </table>	72	71		69	68	67	66	64	63	62		59	58	57	56	55	54	53	52	51	50	49	48	47	46	44	43	42		39	38	37	36	35	34	33			73		32	31	30	29	27		24	23	22	21	20	19	17					15	14	13	12	11			9	8	7	6	5	4	3	2	1		
72	71		69	68	67	66	64	63	62		59	58	57	56	55	54	53																																																																	
52	51	50	49	48	47	46	44	43	42		39	38	37	36	35	34	33																																																																	
		73		32	31	30	29	27		24	23	22	21	20	19	17																																																																		
			15	14	13	12	11			9	8	7	6	5	4	3	2	1																																																																
AVAILABLE	NOT APPLICABLE	34566-9403	G	0	B	ST GRY	<table border="1"> <tr><td></td><td></td><td></td><td>68</td><td>67</td><td>66</td><td>65</td><td></td><td></td><td></td><td></td><td>59</td><td>58</td><td>57</td><td></td><td></td><td>54</td><td>53</td></tr> <tr><td></td><td>51</td><td>50</td><td>49</td><td>48</td><td>46</td><td>45</td><td>43</td><td>42</td><td>41</td><td></td><td>40</td><td>39</td><td>38</td><td>37</td><td>35</td><td>33</td><td></td></tr> <tr><td></td><td></td><td>73</td><td></td><td>32</td><td>31</td><td>30</td><td></td><td></td><td>26</td><td>24</td><td>23</td><td>22</td><td></td><td>20</td><td></td><td></td><td></td></tr> <tr><td></td><td></td><td></td><td>16</td><td></td><td></td><td>13</td><td></td><td></td><td>10</td><td>9</td><td>8</td><td>7</td><td>6</td><td>5</td><td>4</td><td></td><td></td></tr> </table>				68	67	66	65					59	58	57			54	53		51	50	49	48	46	45	43	42	41		40	39	38	37	35	33				73		32	31	30			26	24	23	22		20							16			13			10	9	8	7	6	5	4					
			68	67	66	65					59	58	57			54	53																																																																	
	51	50	49	48	46	45	43	42	41		40	39	38	37	35	33																																																																		
		73		32	31	30			26	24	23	22		20																																																																				
			16			13			10	9	8	7	6	5	4																																																																			
AVAILABLE	NOT APPLICABLE	34566-9503	G	0	A	BLACK	<table border="1"> <tr><td>72</td><td>71</td><td>70</td><td>69</td><td>68</td><td></td><td></td><td>65</td><td>64</td><td>63</td><td>61</td><td>59</td><td>58</td><td>57</td><td>56</td><td></td><td></td><td></td></tr> <tr><td>52</td><td>51</td><td></td><td>49</td><td></td><td>47</td><td></td><td></td><td></td><td></td><td>41</td><td></td><td></td><td>38</td><td>37</td><td>36</td><td>34</td><td>33</td></tr> <tr><td></td><td></td><td>73</td><td></td><td>32</td><td>31</td><td>30</td><td>29</td><td>28</td><td>27</td><td></td><td>24</td><td>23</td><td></td><td></td><td>20</td><td>19</td><td>18</td><td>17</td></tr> <tr><td></td><td></td><td></td><td>16</td><td></td><td></td><td>13</td><td>12</td><td>11</td><td>10</td><td>9</td><td></td><td></td><td></td><td></td><td></td><td></td><td></td><td>1</td></tr> </table>	72	71	70	69	68			65	64	63	61	59	58	57	56				52	51		49		47					41			38	37	36	34	33			73		32	31	30	29	28	27		24	23			20	19	18	17				16			13	12	11	10	9								1	
72	71	70	69	68			65	64	63	61	59	58	57	56																																																																				
52	51		49		47					41			38	37	36	34	33																																																																	
		73		32	31	30	29	28	27		24	23			20	19	18	17																																																																
			16			13	12	11	10	9								1																																																																
AVAILABLE	NOT APPLICABLE	34566-9603	G	0	A	BLACK	<table border="1"> <tr><td></td><td>71</td><td>70</td><td>69</td><td>68</td><td></td><td>66</td><td>65</td><td>64</td><td>63</td><td>61</td><td>59</td><td>58</td><td>57</td><td>56</td><td></td><td></td><td></td></tr> <tr><td>52</td><td></td><td>50</td><td>49</td><td></td><td>47</td><td></td><td></td><td></td><td></td><td>41</td><td></td><td></td><td>38</td><td>37</td><td>36</td><td>35</td><td>34</td><td>33</td></tr> <tr><td></td><td></td><td>73</td><td></td><td>32</td><td>31</td><td>30</td><td>29</td><td>28</td><td>27</td><td></td><td>24</td><td>23</td><td></td><td></td><td>20</td><td>19</td><td>18</td><td>17</td></tr> <tr><td></td><td></td><td></td><td>16</td><td>15</td><td>14</td><td>13</td><td>12</td><td>11</td><td>10</td><td>9</td><td></td><td></td><td></td><td></td><td></td><td></td><td></td><td>1</td></tr> </table>		71	70	69	68		66	65	64	63	61	59	58	57	56				52		50	49		47					41			38	37	36	35	34	33			73		32	31	30	29	28	27		24	23			20	19	18	17				16	15	14	13	12	11	10	9								1
	71	70	69	68		66	65	64	63	61	59	58	57	56																																																																				
52		50	49		47					41			38	37	36	35	34	33																																																																
		73		32	31	30	29	28	27		24	23			20	19	18	17																																																																
			16	15	14	13	12	11	10	9								1																																																																
AVAILABLE	NOT APPLICABLE	34566-9703	G	0	A	BLACK	<table border="1"> <tr><td>72</td><td>71</td><td>70</td><td>69</td><td>68</td><td></td><td></td><td>65</td><td>64</td><td>63</td><td>61</td><td>59</td><td></td><td>57</td><td>56</td><td></td><td></td><td></td></tr> <tr><td>52</td><td>51</td><td>50</td><td>49</td><td></td><td>47</td><td></td><td></td><td></td><td></td><td>41</td><td></td><td></td><td>38</td><td>37</td><td>36</td><td></td><td>34</td><td>33</td></tr> <tr><td></td><td></td><td>73</td><td></td><td>32</td><td>31</td><td>30</td><td>29</td><td>28</td><td>27</td><td></td><td>24</td><td>23</td><td></td><td></td><td>20</td><td>19</td><td>18</td><td>17</td></tr> <tr><td></td><td></td><td></td><td>16</td><td></td><td></td><td>13</td><td>12</td><td>11</td><td>10</td><td>9</td><td></td><td></td><td></td><td></td><td>3</td><td>2</td><td>1</td><td></td></tr> </table>	72	71	70	69	68			65	64	63	61	59		57	56				52	51	50	49		47					41			38	37	36		34	33			73		32	31	30	29	28	27		24	23			20	19	18	17				16			13	12	11	10	9					3	2	1	
72	71	70	69	68			65	64	63	61	59		57	56																																																																				
52	51	50	49		47					41			38	37	36		34	33																																																																
		73		32	31	30	29	28	27		24	23			20	19	18	17																																																																
			16			13	12	11	10	9					3	2	1																																																																	
AVAILABLE	NOT APPLICABLE	34566-9803	G	0	A	BLACK	<table border="1"> <tr><td>72</td><td>71</td><td>70</td><td>69</td><td>68</td><td></td><td></td><td>65</td><td>64</td><td>63</td><td>61</td><td>59</td><td></td><td>57</td><td>56</td><td></td><td></td><td></td></tr> <tr><td>52</td><td>51</td><td>50</td><td>49</td><td></td><td>47</td><td></td><td></td><td></td><td></td><td>41</td><td></td><td></td><td>38</td><td>37</td><td>36</td><td></td><td>34</td><td>33</td></tr> <tr><td></td><td></td><td>73</td><td></td><td>32</td><td>31</td><td>30</td><td>29</td><td>28</td><td>27</td><td></td><td>24</td><td>23</td><td></td><td></td><td>20</td><td>19</td><td>18</td><td>17</td></tr> <tr><td></td><td></td><td></td><td>16</td><td></td><td></td><td>13</td><td>12</td><td>11</td><td>10</td><td>9</td><td></td><td></td><td></td><td></td><td></td><td></td><td></td><td>1</td></tr> </table>	72	71	70	69	68			65	64	63	61	59		57	56				52	51	50	49		47					41			38	37	36		34	33			73		32	31	30	29	28	27		24	23			20	19	18	17				16			13	12	11	10	9								1
72	71	70	69	68			65	64	63	61	59		57	56																																																																				
52	51	50	49		47					41			38	37	36		34	33																																																																
		73		32	31	30	29	28	27		24	23			20	19	18	17																																																																
			16			13	12	11	10	9								1																																																																
AVAILABLE	NOT APPLICABLE	34566-9903	G	0	A	BLACK	<table border="1"> <tr><td></td><td>71</td><td></td><td>69</td><td>68</td><td></td><td></td><td>65</td><td>64</td><td>63</td><td>61</td><td>59</td><td>58</td><td>57</td><td>56</td><td></td><td></td><td></td></tr> <tr><td>52</td><td></td><td>50</td><td>49</td><td></td><td>47</td><td></td><td></td><td></td><td></td><td>41</td><td></td><td></td><td>38</td><td>37</td><td>36</td><td></td><td>34</td><td>33</td></tr> <tr><td></td><td></td><td>73</td><td></td><td>32</td><td>31</td><td>30</td><td>29</td><td>28</td><td>27</td><td></td><td>24</td><td>23</td><td></td><td></td><td>20</td><td>19</td><td>18</td><td>17</td></tr> <tr><td></td><td></td><td></td><td>16</td><td></td><td></td><td>13</td><td>12</td><td>11</td><td>10</td><td>9</td><td></td><td></td><td></td><td></td><td></td><td></td><td></td><td>1</td></tr> </table>		71		69	68			65	64	63	61	59	58	57	56				52		50	49		47					41			38	37	36		34	33			73		32	31	30	29	28	27		24	23			20	19	18	17				16			13	12	11	10	9								1
	71		69	68			65	64	63	61	59	58	57	56																																																																				
52		50	49		47					41			38	37	36		34	33																																																																
		73		32	31	30	29	28	27		24	23			20	19	18	17																																																																
			16			13	12	11	10	9								1																																																																

SEE NEXT PAGE FOR ADDITIONAL NUMBERS

ENTER DESCRIPTION IEC NO: UAU2014-0376 DRAWN BY: 2013/09/05 CHKD: APPR:WKSHY REV:	QUALITY SYMBOLS	GENERAL TOLERANCES (UNLESS SPECIFIED)	DIMENSION STYLE	SCALE	DESIGN UNITS	THIRD ANGLE PROJECTION	
	∇=0 ∇=0 ∇=0	mm INCH 4 PLACES ±--- ±--- 3 PLACES ±--- ±--- 2 PLACES ±--- ±--- 1 PLACE ±--- ±--- 0 PLACE ±--- ±---	MM ONLY	DRAWN BY: SKRAJENDRANA DATE: 2011/02/14 CHECKED BY: MVANSLAMBROU DATE: 2011/02/14 APPROVED BY:	METRIC		
	ANGULAR ±---° DRAFT WHERE APPLICABLE MUST REMAIN WITHIN DIMENSIONS	MATERIAL NO. SEE BOM TABLE	DOCUMENT NO. SD-34566-001	SHEET NO. 14 OF 68			
	THIS DRAWING CONTAINS INFORMATION THAT IS PROPRIETARY TO MOLEX INCORPORATED AND SHOULD NOT BE USED WITHOUT WRITTEN PERMISSION						

STATUS	GM PART #	MATERIAL #	PART/MATERIAL REVISION	WIRE DRESS OPTION	KEY OPTION	COLOR (TPA)	NUMBERS INDICATE CAVITIES OPEN FOR CIRCUITS	
AVAILABLE	NOT APPLICABLE	34566-1013	G	0	A	BLACK	71 70 69 68 67 66 65 64 63 62 61 59 58 57 56 55 54 53 52 51 49 48 47 46 45 44 43 42 41 40 39 38 37 36 35 34 33 32 31 30 29 28 27 26 25 24 23 22 21 20 19 18 17 16 15 14 13 12 11 10 9 8 7 6 5 4 3 2 1	
AVAILABLE	NOT APPLICABLE	34566-1023	G	0	A	BLACK	71 70 69 68 67 66 65 64 63 62 61 59 58 57 56 55 54 53 52 51 49 48 47 46 45 44 43 42 41 40 39 38 37 36 35 34 33 32 31 30 29 28 27 26 25 24 23 22 21 20 19 18 17 16 15 14 13 12 11 10 9 8 7 6 5 4 3 2 1	
AVAILABLE	NOT APPLICABLE	34566-1033	G	0	A	BLACK	72 71 70 69 68 67 66 65 64 63 62 61 59 58 57 56 55 54 53 52 51 49 48 47 46 45 44 43 42 41 40 39 38 37 36 35 34 33 32 31 30 29 28 27 26 25 24 23 22 21 20 19 18 17 16 15 14 13 12 11 10 9 8 7 6 5 4 3 2 1	
AVAILABLE	NOT APPLICABLE	34566-1043	G	0	B	ST GRAY	71 70 69 68 67 66 65 64 63 62 61 59 58 57 56 55 54 53 52 51 49 48 47 46 45 44 43 42 41 40 39 38 37 36 35 34 33 32 31 30 29 28 27 26 25 24 23 22 21 20 19 18 17 16 15 14 13 12 11 10 9 8 7 6 5 4 3 2 1	
AVAILABLE	NOT APPLICABLE	34566-1053	G	0	H	ST GRAY	79 78 77 76 75 74 73 72 71 70 69 68 67 66 65 64 63 62 61 59 58 57 56 55 54 53 52 51 49 48 47 46 45 44 43 42 41 40 39 38 37 36 35 34 33 32 31 30 29 28 27 26 25 24 23 22 21 20 19 18 17 16 15 14 13 12 11 10 9 8 7 6 5 4 3 2 1	
AVAILABLE	NOT APPLICABLE	34566-1063	G	0	B	ST GRAY	71 70 69 68 67 66 65 64 63 62 61 59 58 57 56 55 54 53 52 51 49 48 47 46 45 44 43 42 41 40 39 38 37 36 35 34 33 32 31 30 29 28 27 26 25 24 23 22 21 20 19 18 17 16 15 14 13 12 11 10 9 8 7 6 5 4 3 2 1	
AVAILABLE	NOT APPLICABLE	34566-1073	G	0	A	BLACK	72 71 70 69 68 67 66 65 64 63 62 61 59 58 57 56 55 54 53 52 51 49 48 47 46 45 44 43 42 41 40 39 38 37 36 35 34 33 32 31 30 29 28 27 26 25 24 23 22 21 20 19 18 17 16 15 14 13 12 11 10 9 8 7 6 5 4 3 2 1	
AVAILABLE	NOT APPLICABLE	34566-1083	G	0	B	ST GRAY	71 70 69 68 67 66 65 64 63 62 61 59 58 57 56 55 54 53 52 51 49 48 47 46 45 44 43 42 41 40 39 38 37 36 35 34 33 32 31 30 29 28 27 26 25 24 23 22 21 20 19 18 17 16 15 14 13 12 11 10 9 8 7 6 5 4 3 2 1	

SEE NEXT PAGE FOR ADDITIONAL NUMBERS

ENTER DESCRIPTION EC NO: UAU2014-0376 DRAWN BY: CHYD: APPR: WOSHY 2013/09/05 2013/09/06 REV: 05	QUALITY SYMBOLS	GENERAL TOLERANCES (UNLESS SPECIFIED)	DIMENSION STYLE	SCALE	DESIGN UNITS	THIRD ANGLE PROJECTION	
	∇=0 ∇=0 ∇=0	4 PLACES ±---+ 3 PLACES ±---+ 2 PLACES ±---+ 1 PLACE ±---+ 0 PLACE ±---+	mm INCH ±---+ ±---+ ±---+ ±---+ ±---+ ±---+ ±---+ ±---+	MM ONLY DRAWN BY: SKRA JENDRANA 2011/02/14 CHECKED BY: MVANSLAMBROU 2011/02/14 APPROVED BY:	DATE	METRIC	MX123 66/73/80CKT HRNS CONN ASSY molex
	ANGULAR ±---° DRAFT WHERE APPLICABLE MUST REMAIN WITHIN DIMENSIONS	SEE BOM TABLE THIS DRAWING CONTAINS INFORMATION THAT IS PROPRIETARY TO MOLEX INCORPORATED AND SHOULD NOT BE USED WITHOUT WRITTEN PERMISSION	MATERIAL NO. DOCUMENT NO. SD-34566-001	SHEET NO. 15 OF 68			

STATUS	GM PART #	MATERIAL #	PART/MATERIAL REVISION	WIRE DRESS OPTION	KEY OPTION	COLOR (TPA)	NUMBERS INDICATE CAVITIES OPEN FOR CIRCUITS																																																																						
AVAILABLE	NOT APPLICABLE	34566-1093	G	0	A	BLACK	<table border="1"> <tr><td></td><td>70</td><td>68</td><td>67</td><td>66</td><td></td><td></td><td></td><td></td><td></td><td></td><td></td><td>58</td><td>56</td><td>55</td><td>54</td></tr> <tr><td></td><td></td><td>49</td><td>47</td><td></td><td>44</td><td>43</td><td>42</td><td>41</td><td>39</td><td>37</td><td>36</td><td>34</td><td></td><td></td><td></td></tr> <tr><td>73</td><td></td><td></td><td>31</td><td>30</td><td></td><td>27</td><td>25</td><td>24</td><td></td><td>21</td><td>20</td><td>19</td><td>18</td><td></td><td></td></tr> <tr><td></td><td></td><td></td><td></td><td></td><td>13</td><td></td><td></td><td></td><td>6</td><td>5</td><td>4</td><td>3</td><td>1</td><td></td><td></td></tr> </table>		70	68	67	66								58	56	55	54			49	47		44	43	42	41	39	37	36	34				73			31	30		27	25	24		21	20	19	18								13				6	5	4	3	1								
	70	68	67	66								58	56	55	54																																																														
		49	47		44	43	42	41	39	37	36	34																																																																	
73			31	30		27	25	24		21	20	19	18																																																																
					13				6	5	4	3	1																																																																
AVAILABLE	NOT APPLICABLE	34566-1123	G	0	H	ST GRAY	<table border="1"> <tr><td></td><td>78</td><td></td><td></td><td></td><td></td><td>72</td><td>71</td><td>70</td><td>69</td><td>68</td><td>67</td><td>66</td><td>65</td><td>64</td><td>63</td><td>61</td></tr> <tr><td></td><td>58</td><td>57</td><td>56</td><td></td><td></td><td>53</td><td>52</td><td>51</td><td>50</td><td></td><td></td><td></td><td></td><td>44</td><td>43</td><td>41</td></tr> <tr><td>40</td><td></td><td>37</td><td>35</td><td>34</td><td>33</td><td>32</td><td>30</td><td>29</td><td>27</td><td>26</td><td></td><td></td><td></td><td></td><td></td><td>22</td><td>21</td></tr> <tr><td>20</td><td>19</td><td>18</td><td>17</td><td>16</td><td>14</td><td>12</td><td>10</td><td>9</td><td>8</td><td>7</td><td>6</td><td>5</td><td>3</td><td>2</td><td>1</td><td></td><td></td></tr> </table>		78					72	71	70	69	68	67	66	65	64	63	61		58	57	56			53	52	51	50					44	43	41	40		37	35	34	33	32	30	29	27	26						22	21	20	19	18	17	16	14	12	10	9	8	7	6	5	3	2	1		
	78					72	71	70	69	68	67	66	65	64	63	61																																																													
	58	57	56			53	52	51	50					44	43	41																																																													
40		37	35	34	33	32	30	29	27	26						22	21																																																												
20	19	18	17	16	14	12	10	9	8	7	6	5	3	2	1																																																														
AVAILABLE	NOT APPLICABLE	34566-1133	G	0	A	BLACK	<table border="1"> <tr><td></td><td>70</td><td>68</td><td>67</td><td>66</td><td></td><td></td><td></td><td></td><td></td><td>61</td><td></td><td>58</td><td>57</td><td>55</td><td>54</td></tr> <tr><td></td><td></td><td>49</td><td>47</td><td></td><td>45</td><td>44</td><td>43</td><td>42</td><td>41</td><td>39</td><td>37</td><td>34</td><td></td><td></td><td></td></tr> <tr><td>73</td><td></td><td></td><td>32</td><td>30</td><td></td><td>27</td><td>25</td><td>24</td><td></td><td></td><td></td><td>21</td><td>20</td><td>19</td><td>18</td></tr> <tr><td></td><td></td><td></td><td></td><td></td><td>13</td><td>11</td><td></td><td></td><td></td><td>6</td><td>5</td><td>3</td><td>1</td><td></td><td></td></tr> </table>		70	68	67	66						61		58	57	55	54			49	47		45	44	43	42	41	39	37	34				73			32	30		27	25	24				21	20	19	18						13	11				6	5	3	1								
	70	68	67	66						61		58	57	55	54																																																														
		49	47		45	44	43	42	41	39	37	34																																																																	
73			32	30		27	25	24				21	20	19	18																																																														
					13	11				6	5	3	1																																																																
AVAILABLE	NOT APPLICABLE	34566-1143	G	0	A	BLACK	<table border="1"> <tr><td></td><td></td><td>68</td><td></td><td>65</td><td>63</td><td>61</td><td>59</td><td>58</td><td>56</td><td></td><td></td><td></td><td></td><td></td><td></td><td>53</td></tr> <tr><td>52</td><td>50</td><td></td><td>47</td><td></td><td></td><td>41</td><td></td><td>38</td><td>37</td><td>36</td><td>35</td><td>34</td><td>33</td><td></td><td></td><td></td></tr> <tr><td>73</td><td></td><td>32</td><td>31</td><td>30</td><td>29</td><td>28</td><td>27</td><td>25</td><td>24</td><td>23</td><td>22</td><td>21</td><td>20</td><td>19</td><td>18</td><td>17</td></tr> <tr><td></td><td></td><td>16</td><td>15</td><td>14</td><td>13</td><td>12</td><td>11</td><td>10</td><td>9</td><td></td><td></td><td></td><td></td><td></td><td></td><td>1</td></tr> </table>			68		65	63	61	59	58	56							53	52	50		47			41		38	37	36	35	34	33				73		32	31	30	29	28	27	25	24	23	22	21	20	19	18	17			16	15	14	13	12	11	10	9							1		
		68		65	63	61	59	58	56							53																																																													
52	50		47			41		38	37	36	35	34	33																																																																
73		32	31	30	29	28	27	25	24	23	22	21	20	19	18	17																																																													
		16	15	14	13	12	11	10	9							1																																																													
AVAILABLE	NOT APPLICABLE	34566-1153	G	0	A	BLACK	<table border="1"> <tr><td></td><td>70</td><td></td><td>67</td><td>66</td><td>65</td><td></td><td></td><td></td><td></td><td></td><td></td><td>58</td><td>57</td><td>55</td><td></td><td></td></tr> <tr><td></td><td></td><td>49</td><td>47</td><td></td><td>44</td><td>43</td><td>42</td><td>41</td><td>39</td><td>37</td><td></td><td></td><td></td><td></td><td></td><td></td></tr> <tr><td>73</td><td></td><td></td><td>32</td><td>30</td><td></td><td>27</td><td>25</td><td>24</td><td>23</td><td>21</td><td>20</td><td>19</td><td>18</td><td></td><td></td></tr> <tr><td></td><td></td><td></td><td></td><td></td><td>13</td><td></td><td></td><td></td><td>8</td><td>6</td><td>5</td><td>3</td><td>1</td><td></td><td></td></tr> </table>		70		67	66	65							58	57	55					49	47		44	43	42	41	39	37							73			32	30		27	25	24	23	21	20	19	18								13				8	6	5	3	1						
	70		67	66	65							58	57	55																																																															
		49	47		44	43	42	41	39	37																																																																			
73			32	30		27	25	24	23	21	20	19	18																																																																
					13				8	6	5	3	1																																																																
AVAILABLE	NOT APPLICABLE	34566-1163	G	0	H	ST GRAY	<table border="1"> <tr><td></td><td>78</td><td></td><td></td><td></td><td></td><td>72</td><td>71</td><td>70</td><td>69</td><td>68</td><td></td><td>66</td><td>65</td><td>64</td><td>63</td><td>61</td></tr> <tr><td>60</td><td>59</td><td>58</td><td>57</td><td>56</td><td></td><td>53</td><td>52</td><td>50</td><td></td><td></td><td></td><td></td><td></td><td>44</td><td>43</td><td>41</td></tr> <tr><td>40</td><td></td><td>37</td><td>35</td><td>34</td><td></td><td>32</td><td>30</td><td>29</td><td>27</td><td>26</td><td></td><td></td><td></td><td></td><td></td><td>22</td><td>21</td></tr> <tr><td>20</td><td>19</td><td>18</td><td>17</td><td>16</td><td></td><td>13</td><td>12</td><td></td><td></td><td>8</td><td>6</td><td>5</td><td>3</td><td>2</td><td>1</td><td></td><td></td></tr> </table>		78					72	71	70	69	68		66	65	64	63	61	60	59	58	57	56		53	52	50						44	43	41	40		37	35	34		32	30	29	27	26						22	21	20	19	18	17	16		13	12			8	6	5	3	2	1		
	78					72	71	70	69	68		66	65	64	63	61																																																													
60	59	58	57	56		53	52	50						44	43	41																																																													
40		37	35	34		32	30	29	27	26						22	21																																																												
20	19	18	17	16		13	12			8	6	5	3	2	1																																																														
AVAILABLE	NOT APPLICABLE	34566-1173	G	0	A	BLACK	<table border="1"> <tr><td>72</td><td>71</td><td>69</td><td>68</td><td></td><td>65</td><td>64</td><td>63</td><td>62</td><td>61</td><td>60</td><td>59</td><td>58</td><td>56</td><td>54</td><td></td><td></td></tr> <tr><td>52</td><td>50</td><td>49</td><td>48</td><td>47</td><td>45</td><td></td><td>42</td><td>41</td><td></td><td></td><td></td><td>38</td><td>37</td><td>36</td><td>34</td><td>33</td></tr> <tr><td>73</td><td></td><td>32</td><td>31</td><td>30</td><td>29</td><td>28</td><td>27</td><td>26</td><td>24</td><td>23</td><td></td><td></td><td>20</td><td>19</td><td>18</td><td>17</td></tr> <tr><td></td><td></td><td>16</td><td></td><td>13</td><td>12</td><td>11</td><td>10</td><td>9</td><td></td><td></td><td></td><td></td><td></td><td></td><td></td><td></td></tr> </table>	72	71	69	68		65	64	63	62	61	60	59	58	56	54			52	50	49	48	47	45		42	41				38	37	36	34	33	73		32	31	30	29	28	27	26	24	23			20	19	18	17			16		13	12	11	10	9										
72	71	69	68		65	64	63	62	61	60	59	58	56	54																																																															
52	50	49	48	47	45		42	41				38	37	36	34	33																																																													
73		32	31	30	29	28	27	26	24	23			20	19	18	17																																																													
		16		13	12	11	10	9																																																																					
AVAILABLE	NOT APPLICABLE	34566-1183	G	0	B	ST GRAY	<table border="1"> <tr><td></td><td></td><td></td><td>49</td><td>48</td><td>47</td><td>66</td><td>65</td><td>64</td><td>62</td><td></td><td>59</td><td>57</td><td>55</td><td>53</td><td></td><td></td></tr> <tr><td></td><td></td><td></td><td></td><td></td><td></td><td></td><td></td><td>44</td><td>42</td><td></td><td>39</td><td>37</td><td>35</td><td>33</td><td></td><td></td></tr> <tr><td>73</td><td></td><td></td><td></td><td></td><td></td><td></td><td>29</td><td>28</td><td></td><td></td><td>23</td><td>21</td><td></td><td></td><td></td><td>17</td></tr> <tr><td></td><td></td><td></td><td></td><td></td><td></td><td></td><td>12</td><td></td><td>9</td><td>7</td><td></td><td></td><td></td><td></td><td></td><td></td></tr> </table>				49	48	47	66	65	64	62		59	57	55	53											44	42		39	37	35	33			73							29	28			23	21				17								12		9	7								
			49	48	47	66	65	64	62		59	57	55	53																																																															
								44	42		39	37	35	33																																																															
73							29	28			23	21				17																																																													
							12		9	7																																																																			

ENTER DESCRIPTION ELEC NO: UAU2014-0376 DRAWN BY: CHKD: APPR: IKOSHY 2013/09/05 2013/09/06 DESCRIPTION:	QUALITY SYMBOLS	GENERAL TOLERANCES (UNLESS SPECIFIED)	DIMENSION STYLE	SCALE	DESIGN UNITS	THIRD ANGLE PROJECTION	
	∇=0 ∇=0 ∇=0	4 PLACES ±---+--- 3 PLACES ±---+--- 2 PLACES ±---+--- 1 PLACE ±---+--- 0 PLACE ±---+---	mm INCH ±--- ±--- ±--- ±--- ±--- ±--- ±--- ±---	MM ONLY	DATE	METRIC	SKRAJENDRANA 2011/02/14 MYANSLAMBROU 2011/02/14
	ANGULAR ±---° DRAFT WHERE APPLICABLE MUST REMAIN WITHIN DIMENSIONS	MATERIAL NO. SEE BOM TABLE	DOCUMENT NO. SD-34566-001	SHEET NO. 16 OF 68			
	THIS DRAWING CONTAINS INFORMATION THAT IS PROPRIETARY TO MOLEX INCORPORATED AND SHOULD NOT BE USED WITHOUT WRITTEN PERMISSION						

STATUS	GM PART #	MATERIAL #	PART/MATERIAL REVISION	WIRE DRESS OPTION	KEY OPTION	COLOR (TPA)	NUMBERS INDICATE CAVITIES OPEN FOR CIRCUITS																																																																	
AVAILABLE	NOT APPLICABLE	34566-1193	G	0	A	BLACK	<table border="1"> <tr><td>72</td><td>71</td><td>69</td><td>68</td><td>67</td><td>66</td><td>64</td><td>63</td><td>62</td><td>60</td><td>59</td><td></td><td></td><td></td><td>54</td><td>53</td></tr> <tr><td>52</td><td></td><td>49</td><td>48</td><td>46</td><td>44</td><td>43</td><td>42</td><td></td><td>39</td><td></td><td></td><td></td><td></td><td>34</td><td>33</td></tr> <tr><td></td><td></td><td></td><td>32</td><td></td><td>29</td><td>27</td><td></td><td></td><td>23</td><td></td><td></td><td></td><td></td><td>17</td><td></td></tr> <tr><td></td><td>73</td><td></td><td></td><td>14</td><td>13</td><td>12</td><td>11</td><td>9</td><td>8</td><td>7</td><td>6</td><td>5</td><td>4</td><td>3</td><td>2</td><td>1</td></tr> </table>	72	71	69	68	67	66	64	63	62	60	59				54	53	52		49	48	46	44	43	42		39					34	33				32		29	27			23					17			73			14	13	12	11	9	8	7	6	5	4	3	2	1
72	71	69	68	67	66	64	63	62	60	59				54	53																																																									
52		49	48	46	44	43	42		39					34	33																																																									
			32		29	27			23					17																																																										
	73			14	13	12	11	9	8	7	6	5	4	3	2	1																																																								
AVAILABLE	NOT APPLICABLE	34566-1213	G	0	A	BLACK	<table border="1"> <tr><td>72</td><td>71</td><td>69</td><td>68</td><td>67</td><td>66</td><td>64</td><td>63</td><td>62</td><td></td><td>59</td><td></td><td></td><td></td><td>54</td><td>53</td></tr> <tr><td>52</td><td></td><td></td><td>48</td><td></td><td>46</td><td>44</td><td>43</td><td>42</td><td></td><td>39</td><td></td><td></td><td></td><td></td><td>33</td></tr> <tr><td></td><td></td><td></td><td>32</td><td></td><td>29</td><td>27</td><td></td><td></td><td>24</td><td>23</td><td></td><td></td><td></td><td></td><td>17</td></tr> <tr><td></td><td>73</td><td></td><td></td><td>14</td><td>13</td><td>12</td><td>11</td><td>9</td><td>8</td><td></td><td></td><td>5</td><td>4</td><td>3</td><td>2</td><td>1</td></tr> </table>	72	71	69	68	67	66	64	63	62		59				54	53	52			48		46	44	43	42		39					33				32		29	27			24	23					17		73			14	13	12	11	9	8			5	4	3	2	1
72	71	69	68	67	66	64	63	62		59				54	53																																																									
52			48		46	44	43	42		39					33																																																									
			32		29	27			24	23					17																																																									
	73			14	13	12	11	9	8			5	4	3	2	1																																																								
AVAILABLE	NOT APPLICABLE	34566-1223	G	0	B	ST GRY	<table border="1"> <tr><td></td><td></td><td></td><td></td><td>67</td><td>66</td><td>65</td><td>63</td><td>62</td><td></td><td>59</td><td>57</td><td>55</td><td>53</td><td></td><td></td></tr> <tr><td></td><td></td><td></td><td>48</td><td></td><td></td><td></td><td>43</td><td>42</td><td></td><td>39</td><td>37</td><td>35</td><td>33</td><td></td><td></td></tr> <tr><td></td><td></td><td></td><td></td><td></td><td></td><td>29</td><td>27</td><td>26</td><td></td><td>23</td><td>21</td><td></td><td></td><td>17</td><td></td></tr> <tr><td></td><td>73</td><td></td><td></td><td></td><td></td><td>12</td><td></td><td>9</td><td>7</td><td></td><td></td><td></td><td></td><td></td><td></td></tr> </table>					67	66	65	63	62		59	57	55	53						48				43	42		39	37	35	33									29	27	26		23	21			17			73					12		9	7							
				67	66	65	63	62		59	57	55	53																																																											
			48				43	42		39	37	35	33																																																											
						29	27	26		23	21			17																																																										
	73					12		9	7																																																															
AVAILABLE	NOT APPLICABLE	34566-1233	G	0	B	ST GRY	<table border="1"> <tr><td></td><td></td><td></td><td></td><td></td><td>65</td><td></td><td>62</td><td></td><td>59</td><td>57</td><td>55</td><td>53</td><td></td><td></td></tr> <tr><td></td><td></td><td></td><td>48</td><td>46</td><td></td><td></td><td>42</td><td></td><td>39</td><td>37</td><td>35</td><td>33</td><td></td><td></td></tr> <tr><td></td><td></td><td></td><td></td><td></td><td>29</td><td></td><td>26</td><td></td><td>23</td><td>21</td><td></td><td></td><td>17</td><td></td></tr> <tr><td></td><td>73</td><td></td><td></td><td></td><td>12</td><td></td><td>9</td><td>7</td><td></td><td></td><td></td><td></td><td></td><td></td></tr> </table>						65		62		59	57	55	53						48	46			42		39	37	35	33								29		26		23	21			17			73				12		9	7											
					65		62		59	57	55	53																																																												
			48	46			42		39	37	35	33																																																												
					29		26		23	21			17																																																											
	73				12		9	7																																																																
AVAILABLE	NOT APPLICABLE	34566-1243	G	0	B	ST GRY	<table border="1"> <tr><td></td><td></td><td></td><td></td><td></td><td></td><td></td><td></td><td></td><td>59</td><td>57</td><td>55</td><td>53</td><td></td><td></td></tr> <tr><td></td><td>50</td><td>48</td><td>46</td><td></td><td></td><td></td><td></td><td></td><td>39</td><td>37</td><td>35</td><td>33</td><td></td><td></td></tr> <tr><td></td><td></td><td></td><td></td><td>29</td><td></td><td></td><td></td><td></td><td>23</td><td>21</td><td></td><td></td><td>17</td><td></td></tr> <tr><td></td><td>73</td><td></td><td>15</td><td></td><td>12</td><td></td><td></td><td></td><td>7</td><td>6</td><td>5</td><td>4</td><td>3</td><td></td></tr> </table>										59	57	55	53				50	48	46						39	37	35	33							29					23	21			17			73		15		12				7	6	5	4	3						
									59	57	55	53																																																												
	50	48	46						39	37	35	33																																																												
				29					23	21			17																																																											
	73		15		12				7	6	5	4	3																																																											
AVAILABLE	NOT APPLICABLE	34566-1253	G	9	B	ST GRY	<table border="1"> <tr><td></td><td></td><td>49</td><td>48</td><td>46</td><td>65</td><td></td><td></td><td></td><td>60</td><td>59</td><td>57</td><td>55</td><td>53</td><td></td><td></td></tr> <tr><td></td><td></td><td></td><td></td><td></td><td></td><td></td><td></td><td></td><td>40</td><td>39</td><td>37</td><td>35</td><td>33</td><td></td><td></td></tr> <tr><td></td><td></td><td></td><td></td><td></td><td></td><td></td><td></td><td></td><td>24</td><td>23</td><td>21</td><td></td><td></td><td>2</td><td></td></tr> <tr><td></td><td>73</td><td></td><td></td><td></td><td></td><td></td><td></td><td></td><td></td><td></td><td></td><td></td><td></td><td></td><td></td></tr> </table>			49	48	46	65				60	59	57	55	53												40	39	37	35	33												24	23	21			2			73															
		49	48	46	65				60	59	57	55	53																																																											
									40	39	37	35	33																																																											
									24	23	21			2																																																										
	73																																																																							
AVAILABLE	NOT APPLICABLE	34566-1263	G	9	A	BLACK	<p>NUMBERS IN BOLD MUST USE SAE WIRE MEETING SAE J1128, WIRE SIZE (NO.20) OR (NO.18 MAX. O.D. OF 2.06 MM) PER G.M. DRAWING NUMBER 12582682.</p> <table border="1"> <tr><td>72</td><td>71</td><td>69</td><td>68</td><td>67</td><td>66</td><td>64</td><td>63</td><td>62</td><td></td><td>59</td><td></td><td>56</td><td></td><td>53</td></tr> <tr><td></td><td>50</td><td>48</td><td>46</td><td>44</td><td>43</td><td>42</td><td></td><td></td><td>39</td><td></td><td>36</td><td>35</td><td>33</td><td></td></tr> <tr><td></td><td></td><td>32</td><td>30</td><td>29</td><td>27</td><td></td><td></td><td></td><td>24</td><td>23</td><td></td><td>20</td><td></td><td>17</td></tr> <tr><td></td><td>73</td><td></td><td>14</td><td>13</td><td>12</td><td>11</td><td>9</td><td>8</td><td></td><td></td><td>5</td><td>4</td><td>3</td><td>2</td><td>1</td></tr> </table>	72	71	69	68	67	66	64	63	62		59		56		53		50	48	46	44	43	42			39		36	35	33				32	30	29	27				24	23		20		17		73		14	13	12	11	9	8			5	4	3	2	1				
72	71	69	68	67	66	64	63	62		59		56		53																																																										
	50	48	46	44	43	42			39		36	35	33																																																											
		32	30	29	27				24	23		20		17																																																										
	73		14	13	12	11	9	8			5	4	3	2	1																																																									
AVAILABLE	NOT APPLICABLE	34566-1273	G	0	A	BLACK	<table border="1"> <tr><td></td><td>70</td><td>69</td><td>68</td><td></td><td>65</td><td>64</td><td>63</td><td>61</td><td>59</td><td>58</td><td>57</td><td>56</td><td></td><td></td><td></td></tr> <tr><td>52</td><td>50</td><td>49</td><td>48</td><td>47</td><td></td><td></td><td></td><td>41</td><td></td><td>38</td><td>37</td><td>36</td><td>34</td><td>33</td><td></td></tr> <tr><td></td><td></td><td>32</td><td>31</td><td>30</td><td>29</td><td>28</td><td>27</td><td></td><td>24</td><td>23</td><td></td><td>20</td><td>19</td><td>18</td><td></td></tr> <tr><td></td><td>73</td><td></td><td>16</td><td></td><td>13</td><td>12</td><td>11</td><td>10</td><td>9</td><td></td><td></td><td></td><td></td><td></td><td>1</td></tr> </table>		70	69	68		65	64	63	61	59	58	57	56				52	50	49	48	47				41		38	37	36	34	33				32	31	30	29	28	27		24	23		20	19	18			73		16		13	12	11	10	9						1	
	70	69	68		65	64	63	61	59	58	57	56																																																												
52	50	49	48	47				41		38	37	36	34	33																																																										
		32	31	30	29	28	27		24	23		20	19	18																																																										
	73		16		13	12	11	10	9						1																																																									

ENTER DESCRIPTION IEC NO: UAU2014-0376 DRAWN BY: 2013/09/05 CHKD: 2013/09/06 APPR: WOSHY REV: 05	QUALITY SYMBOLS ∇=0 ∇=0 ∇=0	GENERAL TOLERANCES (UNLESS SPECIFIED): <table border="1"> <tr><th></th><th>mm</th><th>INCH</th></tr> <tr><td>4 PLACES</td><td>±---</td><td>±---</td></tr> <tr><td>3 PLACES</td><td>±---</td><td>±---</td></tr> <tr><td>2 PLACES</td><td>±---</td><td>±---</td></tr> <tr><td>1 PLACE</td><td>±---</td><td>±---</td></tr> <tr><td>0 PLACE</td><td>±---</td><td>±---</td></tr> </table>		mm	INCH	4 PLACES	±---	±---	3 PLACES	±---	±---	2 PLACES	±---	±---	1 PLACE	±---	±---	0 PLACE	±---	±---	DIMENSION STYLE MM ONLY	SCALE METRIC	DESIGN UNITS METRIC	THIRD ANGLE PROJECTION
		mm	INCH																					
	4 PLACES	±---	±---																					
	3 PLACES	±---	±---																					
2 PLACES	±---	±---																						
1 PLACE	±---	±---																						
0 PLACE	±---	±---																						
DRAWN BY: SKRAJENDRANA DATE: 2011/02/14 CHECKED BY: MVANSLAMBROU DATE: 2011/02/14 APPROVED BY:	TITLE MX123 66/73/80CKT HRNS CONN ASSY	MATERIAL NO. SD-34566-001	DOCUMENT NO.	SHEET NO. 17 OF 68																				
ANGULAR ±---° DRAFT WHERE APPLICABLE MUST REMAIN WITHIN DIMENSIONS	SEE BOM TABLE	THIS DRAWING CONTAINS INFORMATION THAT IS PROPRIETARY TO MOLEX INCORPORATED AND SHOULD NOT BE USED WITHOUT WRITTEN PERMISSION																						

STATUS	GM PART #	MATERIAL #	PART / MATERIAL REVISION	WIRE DRESS OPTION	KEY OPTION	COLOR (TFAI)	NUMBERS INDICATE CAVITIES OPEN FOR CIRCUITS																																																																													
AVAILABLE	NOT APPLICABLE	34566-1283	G	0	A	BLACK	<table border="1"> <tr><td>72</td><td>71</td><td>70</td><td>69</td><td>68</td><td>66</td><td>65</td><td>64</td><td>63</td><td>61</td><td>59</td><td>58</td><td>57</td><td>56</td><td>54</td></tr> <tr><td>52</td><td>50</td><td>49</td><td>48</td><td>47</td><td></td><td></td><td></td><td></td><td>42</td><td>41</td><td>38</td><td>37</td><td>36</td><td>34</td><td>33</td></tr> <tr><td>73</td><td></td><td>32</td><td>31</td><td>30</td><td>29</td><td>28</td><td>27</td><td>26</td><td>24</td><td>23</td><td></td><td></td><td>20</td><td>19</td><td>18</td></tr> <tr><td></td><td></td><td>16</td><td></td><td></td><td>13</td><td>12</td><td>11</td><td>10</td><td>9</td><td></td><td></td><td></td><td></td><td></td><td></td></tr> </table>	72	71	70	69	68	66	65	64	63	61	59	58	57	56	54	52	50	49	48	47					42	41	38	37	36	34	33	73		32	31	30	29	28	27	26	24	23			20	19	18			16			13	12	11	10	9																				
72	71	70	69	68	66	65	64	63	61	59	58	57	56	54																																																																						
52	50	49	48	47					42	41	38	37	36	34	33																																																																					
73		32	31	30	29	28	27	26	24	23			20	19	18																																																																					
		16			13	12	11	10	9																																																																											
AVAILABLE	NOT APPLICABLE	34566-1293	G	0	A	BLACK	<table border="1"> <tr><td></td><td></td><td>68</td><td></td><td>65</td><td>63</td><td>61</td><td>59</td><td>58</td><td>56</td><td></td><td></td><td></td><td></td><td></td></tr> <tr><td>52</td><td>50</td><td></td><td>47</td><td></td><td></td><td>41</td><td></td><td>38</td><td>37</td><td>36</td><td></td><td></td><td>34</td><td>33</td></tr> <tr><td>73</td><td></td><td>32</td><td>31</td><td>30</td><td>29</td><td>28</td><td>27</td><td>24</td><td>23</td><td></td><td></td><td>20</td><td>19</td><td>18</td></tr> <tr><td></td><td></td><td>16</td><td></td><td></td><td>13</td><td>12</td><td>11</td><td>10</td><td>9</td><td></td><td></td><td></td><td></td><td>1</td></tr> </table>			68		65	63	61	59	58	56						52	50		47			41		38	37	36			34	33	73		32	31	30	29	28	27	24	23			20	19	18			16			13	12	11	10	9					1																	
		68		65	63	61	59	58	56																																																																											
52	50		47			41		38	37	36			34	33																																																																						
73		32	31	30	29	28	27	24	23			20	19	18																																																																						
		16			13	12	11	10	9					1																																																																						
AVAILABLE	NOT APPLICABLE	34566-1313	G	0	H	ST GRAY	<table border="1"> <tr><td>80</td><td>78</td><td></td><td></td><td></td><td>72</td><td>71</td><td>70</td><td>69</td><td>68</td><td>66</td><td>65</td><td>64</td><td>63</td><td>61</td></tr> <tr><td></td><td>58</td><td>57</td><td>56</td><td>55</td><td>54</td><td>53</td><td></td><td></td><td></td><td>46</td><td>44</td><td>43</td><td>42</td><td></td></tr> <tr><td>40</td><td></td><td>37</td><td>35</td><td></td><td></td><td>32</td><td>30</td><td>29</td><td>27</td><td>26</td><td></td><td></td><td></td><td>21</td></tr> <tr><td>20</td><td>19</td><td>18</td><td>17</td><td>15</td><td></td><td>12</td><td></td><td></td><td>8</td><td>6</td><td>5</td><td>3</td><td>2</td><td></td></tr> </table>	80	78				72	71	70	69	68	66	65	64	63	61		58	57	56	55	54	53				46	44	43	42		40		37	35			32	30	29	27	26				21	20	19	18	17	15		12			8	6	5	3	2																		
80	78				72	71	70	69	68	66	65	64	63	61																																																																						
	58	57	56	55	54	53				46	44	43	42																																																																							
40		37	35			32	30	29	27	26				21																																																																						
20	19	18	17	15		12			8	6	5	3	2																																																																							
AVAILABLE	NOT APPLICABLE	34566-1323	G	0	A	BLACK	<table border="1"> <tr><td>72</td><td>71</td><td>70</td><td>69</td><td>68</td><td>67</td><td>66</td><td>65</td><td>64</td><td>63</td><td>62</td><td>60</td><td>59</td><td>58</td><td>57</td><td>56</td><td>55</td><td>54</td><td>53</td></tr> <tr><td>52</td><td>51</td><td>50</td><td>49</td><td>48</td><td>47</td><td>46</td><td>45</td><td>44</td><td>43</td><td>42</td><td>41</td><td>40</td><td>39</td><td>38</td><td>37</td><td>36</td><td>35</td><td>34</td><td>33</td></tr> <tr><td>73</td><td></td><td>32</td><td>31</td><td>30</td><td>29</td><td>28</td><td>27</td><td>25</td><td>24</td><td>23</td><td>22</td><td>21</td><td>20</td><td>19</td><td>18</td><td>17</td><td></td><td></td></tr> <tr><td></td><td></td><td>16</td><td>15</td><td>14</td><td>13</td><td>12</td><td>11</td><td>9</td><td>8</td><td>7</td><td>6</td><td>5</td><td>4</td><td>3</td><td>2</td><td>1</td><td></td><td></td></tr> </table>	72	71	70	69	68	67	66	65	64	63	62	60	59	58	57	56	55	54	53	52	51	50	49	48	47	46	45	44	43	42	41	40	39	38	37	36	35	34	33	73		32	31	30	29	28	27	25	24	23	22	21	20	19	18	17					16	15	14	13	12	11	9	8	7	6	5	4	3	2	1		
72	71	70	69	68	67	66	65	64	63	62	60	59	58	57	56	55	54	53																																																																		
52	51	50	49	48	47	46	45	44	43	42	41	40	39	38	37	36	35	34	33																																																																	
73		32	31	30	29	28	27	25	24	23	22	21	20	19	18	17																																																																				
		16	15	14	13	12	11	9	8	7	6	5	4	3	2	1																																																																				
AVAILABLE	NOT APPLICABLE	34566-1333	G	0	A	BLACK	<table border="1"> <tr><td></td><td>70</td><td>69</td><td>68</td><td></td><td>65</td><td>64</td><td></td><td></td><td>59</td><td>58</td><td>56</td><td></td><td></td><td></td></tr> <tr><td>52</td><td>50</td><td>49</td><td>47</td><td></td><td></td><td></td><td></td><td>41</td><td></td><td>38</td><td>37</td><td>36</td><td></td><td>34</td></tr> <tr><td>73</td><td></td><td>32</td><td>31</td><td>30</td><td>29</td><td>28</td><td>27</td><td></td><td>23</td><td></td><td></td><td>20</td><td>19</td><td>18</td></tr> <tr><td></td><td></td><td>16</td><td></td><td></td><td>13</td><td>12</td><td>11</td><td>10</td><td>9</td><td>8</td><td>6</td><td></td><td></td><td>1</td></tr> </table>		70	69	68		65	64			59	58	56				52	50	49	47					41		38	37	36		34	73		32	31	30	29	28	27		23			20	19	18			16			13	12	11	10	9	8	6			1																	
	70	69	68		65	64			59	58	56																																																																									
52	50	49	47					41		38	37	36		34																																																																						
73		32	31	30	29	28	27		23			20	19	18																																																																						
		16			13	12	11	10	9	8	6			1																																																																						
AVAILABLE	NOT APPLICABLE	34566-1343	G	0	A	BLACK	<table border="1"> <tr><td>72</td><td>71</td><td></td><td>69</td><td>67</td><td>65</td><td>64</td><td>63</td><td></td><td>59</td><td>58</td><td>57</td><td>56</td><td></td><td></td></tr> <tr><td></td><td>50</td><td>49</td><td>48</td><td>47</td><td></td><td></td><td></td><td>41</td><td></td><td>38</td><td>37</td><td>36</td><td></td><td>34</td></tr> <tr><td>73</td><td></td><td>32</td><td>31</td><td>30</td><td>29</td><td>28</td><td>27</td><td></td><td>23</td><td></td><td></td><td>20</td><td>19</td><td>18</td></tr> <tr><td></td><td></td><td>16</td><td></td><td></td><td>13</td><td>12</td><td>11</td><td>10</td><td>9</td><td>7</td><td>6</td><td>4</td><td>3</td><td>1</td></tr> </table>	72	71		69	67	65	64	63		59	58	57	56				50	49	48	47				41		38	37	36		34	73		32	31	30	29	28	27		23			20	19	18			16			13	12	11	10	9	7	6	4	3	1																	
72	71		69	67	65	64	63		59	58	57	56																																																																								
	50	49	48	47				41		38	37	36		34																																																																						
73		32	31	30	29	28	27		23			20	19	18																																																																						
		16			13	12	11	10	9	7	6	4	3	1																																																																						
AVAILABLE	NOT APPLICABLE	34566-1353	G	0	H	ST GRAY	<table border="1"> <tr><td></td><td>79</td><td>78</td><td>77</td><td>76</td><td>75</td><td>74</td><td>73</td><td>72</td><td>71</td><td>70</td><td>69</td><td>68</td><td>66</td><td>65</td><td>64</td><td>63</td><td>61</td></tr> <tr><td>60</td><td>59</td><td>58</td><td>57</td><td>56</td><td></td><td></td><td>53</td><td></td><td>50</td><td></td><td></td><td></td><td></td><td>44</td><td>43</td><td>41</td><td></td></tr> <tr><td>40</td><td>39</td><td>38</td><td>37</td><td></td><td>35</td><td>34</td><td></td><td>32</td><td>30</td><td>29</td><td></td><td>27</td><td>26</td><td></td><td></td><td>22</td><td>21</td></tr> <tr><td>20</td><td>19</td><td>18</td><td>17</td><td></td><td></td><td></td><td>13</td><td>12</td><td>11</td><td></td><td></td><td>8</td><td>6</td><td>5</td><td>3</td><td>2</td><td></td></tr> </table>		79	78	77	76	75	74	73	72	71	70	69	68	66	65	64	63	61	60	59	58	57	56			53		50					44	43	41		40	39	38	37		35	34		32	30	29		27	26			22	21	20	19	18	17				13	12	11			8	6	5	3	2						
	79	78	77	76	75	74	73	72	71	70	69	68	66	65	64	63	61																																																																			
60	59	58	57	56			53		50					44	43	41																																																																				
40	39	38	37		35	34		32	30	29		27	26			22	21																																																																			
20	19	18	17				13	12	11			8	6	5	3	2																																																																				
AVAILABLE	NOT APPLICABLE	34566-1363	G	0	A	BLACK	<table border="1"> <tr><td>72</td><td>71</td><td></td><td>69</td><td>68</td><td>67</td><td>66</td><td>64</td><td>63</td><td>62</td><td></td><td>59</td><td></td><td></td><td></td><td></td><td></td><td>53</td></tr> <tr><td></td><td></td><td></td><td>48</td><td>46</td><td>44</td><td>43</td><td>42</td><td></td><td></td><td></td><td>39</td><td></td><td></td><td></td><td></td><td></td><td>33</td></tr> <tr><td>73</td><td></td><td>32</td><td></td><td>29</td><td>27</td><td></td><td></td><td></td><td></td><td>24</td><td>23</td><td></td><td></td><td></td><td></td><td></td><td>17</td></tr> <tr><td></td><td></td><td></td><td></td><td>14</td><td>13</td><td>12</td><td>11</td><td>9</td><td>8</td><td></td><td></td><td></td><td>5</td><td>4</td><td>3</td><td>2</td><td>1</td></tr> </table>	72	71		69	68	67	66	64	63	62		59						53				48	46	44	43	42				39						33	73		32		29	27					24	23						17					14	13	12	11	9	8				5	4	3	2	1					
72	71		69	68	67	66	64	63	62		59						53																																																																			
			48	46	44	43	42				39						33																																																																			
73		32		29	27					24	23						17																																																																			
				14	13	12	11	9	8				5	4	3	2	1																																																																			

ENTER DESCRIPTION EC NO: UAU2014-0376 DRAWN BY: CHYK CHKD: APPR: WOSH 2013/09/05 2013/09/06 DESCRIPTION	QUALITY SYMBOLS	GENERAL TOLERANCES (UNLESS SPECIFIED)	DIMENSION STYLE	SCALE	DESIGN UNITS	THIRD ANGLE PROJECTION	
	▽=0	4 PLACES # --- # ---	mm INCH	MM ONLY	METRIC	☉	
	▽=0	3 PLACES # --- # ---					
	▽=0	2 PLACES # --- # ---					
	1 PLACE # --- # ---						
	0 PLACE # --- # ---						
	ANGULAR ± ---°						
	DRAFT WHERE APPLICABLE MUST REMAIN WITHIN DIMENSIONS						
			DRAWN BY: SKRA JENDRANA	DATE: 2011/02/14	TITLE: MX123 66/73/80CKT HRNS CONN ASSY		
			CHECKED BY: MVANSLAMBROU	DATE: 2011/02/14			
			APPROVED BY:	DATE:			
			MATERIAL NO. SEE BOM TABLE	DOCUMENT NO. SD-34566-001			
						SHEET NO. 18 OF 68	
			THIS DRAWING CONTAINS INFORMATION THAT IS PROPRIETARY TO MOLEX INCORPORATED AND SHOULD NOT BE USED WITHOUT WRITTEN PERMISSION				

STATUS	GM PART #	MATERIAL #	PART/MATERIAL REVISION	WIRE DRESS OPTION	KEY OPTION	COLOR (TPA)	NUMBERS INDICATE CAVITIES OPEN FOR CIRCUITS																																																																										
AVAILABLE	NOT APPLICABLE	34566-1473	G	0	A	BLACK	<table border="1"> <tr><td>72</td><td>71</td><td>69</td><td>68</td><td>67</td><td>66</td><td>64</td><td>63</td><td>62</td><td>59</td><td></td><td></td><td></td><td></td><td>54</td><td>53</td></tr> <tr><td>52</td><td></td><td>49</td><td>48</td><td>46</td><td>44</td><td>43</td><td>42</td><td></td><td>39</td><td></td><td></td><td></td><td></td><td>34</td><td>33</td></tr> <tr><td></td><td></td><td></td><td>32</td><td></td><td>29</td><td>27</td><td></td><td></td><td>24</td><td>23</td><td></td><td></td><td></td><td></td><td>17</td></tr> <tr><td></td><td></td><td></td><td></td><td></td><td>14</td><td>13</td><td>12</td><td>11</td><td>9</td><td>8</td><td>7</td><td>6</td><td>5</td><td>4</td><td>3</td><td>2</td><td>1</td></tr> </table>	72	71	69	68	67	66	64	63	62	59					54	53	52		49	48	46	44	43	42		39					34	33				32		29	27			24	23					17						14	13	12	11	9	8	7	6	5	4	3	2	1								
72	71	69	68	67	66	64	63	62	59					54	53																																																																		
52		49	48	46	44	43	42		39					34	33																																																																		
			32		29	27			24	23					17																																																																		
					14	13	12	11	9	8	7	6	5	4	3	2	1																																																																
AVAILABLE	NOT APPLICABLE	34566-1483	G	0	A	BLACK	<table border="1"> <tr><td>72</td><td>71</td><td>69</td><td>68</td><td></td><td></td><td>65</td><td>64</td><td>63</td><td>61</td><td>59</td><td>58</td><td></td><td></td><td>56</td><td></td><td></td><td></td></tr> <tr><td>52</td><td></td><td>50</td><td>49</td><td></td><td>47</td><td></td><td></td><td></td><td>41</td><td></td><td></td><td></td><td></td><td>38</td><td>37</td><td>36</td><td>34</td><td>33</td></tr> <tr><td></td><td></td><td></td><td>32</td><td>31</td><td>30</td><td>29</td><td>28</td><td>27</td><td></td><td>24</td><td>23</td><td></td><td></td><td>20</td><td>19</td><td>18</td><td>17</td></tr> <tr><td></td><td></td><td></td><td></td><td></td><td></td><td></td><td></td><td></td><td></td><td></td><td></td><td></td><td></td><td></td><td></td><td></td><td></td><td>1</td></tr> </table>	72	71	69	68			65	64	63	61	59	58			56				52		50	49		47				41					38	37	36	34	33				32	31	30	29	28	27		24	23			20	19	18	17																			1
72	71	69	68			65	64	63	61	59	58			56																																																																			
52		50	49		47				41					38	37	36	34	33																																																															
			32	31	30	29	28	27		24	23			20	19	18	17																																																																
																		1																																																															
AVAILABLE	NOT APPLICABLE	34566-1493	G	0	B	ST GRAY	<table border="1"> <tr><td></td><td></td><td></td><td>68</td><td></td><td></td><td></td><td></td><td></td><td></td><td>59</td><td>58</td><td>57</td><td></td><td>55</td><td>53</td></tr> <tr><td></td><td></td><td></td><td>49</td><td>48</td><td>46</td><td></td><td></td><td></td><td></td><td>39</td><td>38</td><td>37</td><td></td><td>35</td><td>33</td></tr> <tr><td></td><td></td><td></td><td></td><td></td><td></td><td>29</td><td></td><td></td><td></td><td>23</td><td>22</td><td>21</td><td></td><td></td><td>18</td><td>17</td></tr> <tr><td></td><td></td><td></td><td></td><td></td><td></td><td></td><td></td><td></td><td></td><td>7</td><td></td><td></td><td></td><td></td><td></td><td></td><td>1</td></tr> </table>				68							59	58	57		55	53				49	48	46					39	38	37		35	33							29				23	22	21			18	17											7							1							
			68							59	58	57		55	53																																																																		
			49	48	46					39	38	37		35	33																																																																		
						29				23	22	21			18	17																																																																	
										7							1																																																																
AVAILABLE	NOT APPLICABLE	34566-1513	G	0	B	ST GRAY	<table border="1"> <tr><td></td><td></td><td></td><td></td><td></td><td></td><td>65</td><td></td><td></td><td></td><td>59</td><td></td><td>57</td><td></td><td>55</td><td>53</td></tr> <tr><td></td><td></td><td></td><td>49</td><td>48</td><td>46</td><td></td><td></td><td></td><td></td><td>39</td><td></td><td>37</td><td></td><td>35</td><td>33</td></tr> <tr><td></td><td></td><td></td><td></td><td></td><td></td><td>29</td><td></td><td></td><td></td><td>23</td><td></td><td>21</td><td></td><td></td><td>18</td><td>17</td></tr> <tr><td></td><td></td><td></td><td></td><td></td><td></td><td></td><td></td><td></td><td></td><td>7</td><td></td><td></td><td></td><td></td><td></td><td></td><td>1</td></tr> </table>							65				59		57		55	53				49	48	46					39		37		35	33							29				23		21			18	17											7							1							
						65				59		57		55	53																																																																		
			49	48	46					39		37		35	33																																																																		
						29				23		21			18	17																																																																	
										7							1																																																																
AVAILABLE	NOT APPLICABLE	34566-1523	G	0	A	BLACK	<table border="1"> <tr><td></td><td></td><td>70</td><td>69</td><td>68</td><td></td><td>65</td><td>64</td><td></td><td></td><td>59</td><td>58</td><td></td><td></td><td>56</td><td>54</td></tr> <tr><td>52</td><td></td><td>50</td><td>49</td><td></td><td>47</td><td></td><td></td><td>42</td><td>41</td><td></td><td></td><td></td><td></td><td>38</td><td>37</td><td>36</td><td>34</td></tr> <tr><td></td><td></td><td></td><td>32</td><td>31</td><td>30</td><td>29</td><td>28</td><td>27</td><td>26</td><td></td><td>23</td><td></td><td></td><td>20</td><td>19</td><td>18</td><td>17</td></tr> <tr><td></td><td></td><td></td><td></td><td></td><td></td><td></td><td></td><td></td><td></td><td>9</td><td>8</td><td></td><td></td><td></td><td></td><td></td><td>1</td></tr> </table>			70	69	68		65	64			59	58			56	54	52		50	49		47			42	41					38	37	36	34				32	31	30	29	28	27	26		23			20	19	18	17											9	8						1				
		70	69	68		65	64			59	58			56	54																																																																		
52		50	49		47			42	41					38	37	36	34																																																																
			32	31	30	29	28	27	26		23			20	19	18	17																																																																
										9	8						1																																																																
AVAILABLE	NOT APPLICABLE	34566-1533	G	0	A	BLACK	<table border="1"> <tr><td>72</td><td>71</td><td>70</td><td>69</td><td>68</td><td></td><td>65</td><td>64</td><td>63</td><td>61</td><td>59</td><td>58</td><td>57</td><td>56</td><td></td><td></td><td></td><td></td></tr> <tr><td>52</td><td>51</td><td>50</td><td>49</td><td></td><td>47</td><td></td><td></td><td></td><td>41</td><td></td><td></td><td>38</td><td>37</td><td>36</td><td></td><td>34</td><td>33</td></tr> <tr><td></td><td></td><td></td><td>32</td><td>31</td><td>30</td><td>29</td><td>28</td><td>27</td><td></td><td>24</td><td>23</td><td></td><td></td><td>20</td><td>19</td><td>18</td><td>17</td></tr> <tr><td></td><td></td><td></td><td></td><td></td><td></td><td></td><td></td><td></td><td></td><td></td><td></td><td></td><td></td><td></td><td>3</td><td>2</td><td>1</td></tr> </table>	72	71	70	69	68		65	64	63	61	59	58	57	56					52	51	50	49		47				41			38	37	36		34	33				32	31	30	29	28	27		24	23			20	19	18	17																3	2	1		
72	71	70	69	68		65	64	63	61	59	58	57	56																																																																				
52	51	50	49		47				41			38	37	36		34	33																																																																
			32	31	30	29	28	27		24	23			20	19	18	17																																																																
															3	2	1																																																																
AVAILABLE	NOT APPLICABLE	34566-1543	G	0	B	ST GRAY	<table border="1"> <tr><td></td><td></td><td></td><td>69</td><td>68</td><td>66</td><td></td><td></td><td></td><td></td><td>59</td><td></td><td>57</td><td></td><td>55</td><td>53</td></tr> <tr><td></td><td></td><td></td><td>49</td><td>48</td><td>46</td><td></td><td></td><td></td><td></td><td>39</td><td></td><td>37</td><td></td><td>35</td><td>33</td></tr> <tr><td></td><td></td><td></td><td></td><td></td><td></td><td>29</td><td></td><td></td><td></td><td>23</td><td></td><td>21</td><td></td><td></td><td></td><td></td><td></td></tr> <tr><td></td><td></td><td></td><td></td><td></td><td></td><td></td><td></td><td></td><td></td><td>7</td><td></td><td></td><td></td><td></td><td></td><td></td><td></td></tr> </table>				69	68	66					59		57		55	53				49	48	46					39		37		35	33							29				23		21																7													
			69	68	66					59		57		55	53																																																																		
			49	48	46					39		37		35	33																																																																		
						29				23		21																																																																					
										7																																																																							
AVAILABLE	NOT APPLICABLE	34566-1583	G	0	A	BLACK	<table border="1"> <tr><td></td><td></td><td>70</td><td></td><td>67</td><td>66</td><td>65</td><td></td><td></td><td>61</td><td></td><td></td><td>58</td><td>57</td><td></td><td>55</td><td>54</td></tr> <tr><td></td><td></td><td>49</td><td></td><td>47</td><td>45</td><td>44</td><td>43</td><td>42</td><td>41</td><td></td><td>39</td><td></td><td>37</td><td></td><td>34</td><td></td></tr> <tr><td></td><td></td><td></td><td></td><td>32</td><td>30</td><td></td><td>27</td><td>25</td><td>24</td><td></td><td></td><td>21</td><td>20</td><td>19</td><td>18</td><td>17</td></tr> <tr><td></td><td></td><td></td><td></td><td></td><td></td><td></td><td></td><td></td><td></td><td></td><td></td><td></td><td></td><td></td><td></td><td></td><td>1</td></tr> </table>			70		67	66	65			61			58	57		55	54			49		47	45	44	43	42	41		39		37		34						32	30		27	25	24			21	20	19	18	17																		1					
		70		67	66	65			61			58	57		55	54																																																																	
		49		47	45	44	43	42	41		39		37		34																																																																		
				32	30		27	25	24			21	20	19	18	17																																																																	
																	1																																																																

ENTER DESCRIPTION IEC NO: UAU2014-0376 DRAWN BY: SKRAJENDRANA CHKD: MYANSLAMBROU APPR: IKOSHY 2013/09/05 2013/09/06 DESCRIPTION	QUALITY SYMBOLS	GENERAL TOLERANCES (UNLESS SPECIFIED)	DIMENSION STYLE	SCALE	DESIGN UNITS	THIRD ANGLE PROJECTION
	▽=0	mm INCH	MM ONLY	MM ONLY	METRIC	
	▽=0	4 PLACES ± --- ± ---	DRAWN BY DATE	TITLE		
	▽=0	3 PLACES ± --- ± ---	CHECKED BY DATE	MX123 66/73/80CKT HRNS CONN ASSY		
	2 PLACES ± --- ± ---	APPROVED BY DATE	MATERIAL NO.	DOCUMENT NO.	SHEET NO.	
	1 PLACE ± --- ± ---		SEE BOM TABLE	SD-34566-001	20 OF 68	
	0 PLACE ± --- ± ---	ANGULAR ± ---°	THIS DRAWING CONTAINS INFORMATION THAT IS PROPRIETARY TO MOLEX INCORPORATED AND SHOULD NOT BE USED WITHOUT WRITTEN PERMISSION			
		DRAFT WHERE APPLICABLE MUST REMAIN WITHIN DIMENSIONS				

STATUS	GM PART #	MATERIAL #	PART / MATERIAL REVISION	WIRE DRESS OPTION	KEY OPTION	COLOR (TFA)	NUMBERS INDICATE CAVITIES OPEN FOR CIRCUITS															
AVAILABLE	NOT APPLICABLE	34566-1873	G	0	C	BLUE	72	70		67	66		63	62		59	57		53			
							52	51			46	44	42	40	39				34	33		
							73		32	30		27	26	25		22	21	20				
									15	14			10	9		6	5	4				
AVAILABLE	NOT APPLICABLE	34566-1883	G	0	A	BLACK		70		68	67	66	65				58	57	55			
								49		47		44	43	42	41	40	39		37	35		
							73		32	30		27	25	24		21	20	19	18	17		
									16	15	13		10	9	8	6	5	3	2	1		
AVAILABLE	NOT APPLICABLE	34566-1893	G	0	C	BLUE	72	70			66		63			59	57		53			
							52	51			46	44	42	40	39				34	33		
							73		32	30		27	26	25		22	21	20				
									15	14			10	9		6	5	4				
AVAILABLE	NOT APPLICABLE	34566-1913	G	0	B	ST GRAY	72	70	68	66					60	59		55	54	53		
							52	50	48	46					40	39		35	34	33		
							73		32	31	30	29	28	27	26	25	24					
									16					10	9	8						
AVAILABLE	NOT APPLICABLE	34566-1923	G	0	A	BLACK			69				63				58	56	55	54	53	
							52	51	49				44	43	42	41			36	35	34	33
							73		32			28	26						19	18		
									16			12	10						3			
AVAILABLE	NOT APPLICABLE	34566-1933	G	0	A	BLACK		70		67	66	65				58	57	55				
								49		47		44	43	42	41	40	39		37	35		
							73		32	30		27	25	24		21	20	19	18	17		
									16	15	13		10	9	8	6	5	3	2	1		
AVAILABLE	NOT APPLICABLE	34566-1943	G	0	A	BLACK		70		67	66	65				58	57	55				
							51	49		47		44	43	42	41	40	39		37	35		
							73		32	30		27	25	24		21	20	19	18	17		
									16	15	13		10	9	8	6	5	3	2	1		
AVAILABLE	NOT APPLICABLE	34566-1953	G	0	C	BLUE	72	70			66		63			59	57		53			
							52	51		48	47	46	44	42	40	39				34	33	
							73			30		26	25		22	21	20					
									15	14			10	9		6	5	4				
AVAILABLE	NOT APPLICABLE	34566-1963	G	0	C	BLUE	72	70			66		63			59	57		53			
							52	51			46	44	42	40	39				34	33		
							73			30		26	25		22	21	20					
									15	14			10	9		6	5	4				

ENTER DESCRIPTION IEC NO: UAU2014-0376 DRAWN BY: SKRAJENDRANA CHKD: MVANSLAMBROU APPR: WOSHY REV: 05	2013/09/05 2013/09/06	QUALITY SYMBOLS ∇=0 ∇=0 ∇=0	GENERAL TOLERANCES (UNLESS SPECIFIED) mm INCH 4 PLACES ±---+ 3 PLACES ±---+ 2 PLACES ±---+ 1 PLACE ±---+ 0 PLACE ±---+	DIMENSION STYLE MM ONLY	SCALE METRIC	DESIGN UNITS METRIC	THIRD ANGLE PROJECTION	
	DRAWN BY: SKRAJENDRANA CHECKED BY: MVANSLAMBROU APPROVED BY:	DATE: 2011/02/14 DATE: 2011/02/14 DATE:	TITLE MX123 66/73/80CKT HRNS CONN ASSY	MATERIAL NO. SEE BOM TABLE	DOCUMENT NO. SD-34566-001	SHEET NO. 24 OF 68		
	THIS DRAWING CONTAINS INFORMATION THAT IS PROPRIETARY TO MOLEX INCORPORATED AND SHOULD NOT BE USED WITHOUT WRITTEN PERMISSION							
	SIZE D							

STATUS	GM PART #	MATERIAL #	PART/MATERIAL REVISION	WIRE DRESS OPTION	KEY OPTION	COLOR (TPA)	NUMBERS INDICATE CAVITIES OPEN FOR CIRCUITS																																																																																		
AVAILABLE	NOT APPLICABLE	34566-1973	G	0	A	BLACK	<table border="1"> <tr><td></td><td></td><td>69</td><td></td><td></td><td></td><td>63</td><td></td><td></td><td></td><td></td><td></td><td>56</td><td>55</td><td>54</td><td>53</td></tr> <tr><td>52</td><td>51</td><td>49</td><td></td><td></td><td></td><td>44</td><td>43</td><td>42</td><td>41</td><td></td><td></td><td></td><td>36</td><td>35</td><td>34</td><td>33</td></tr> <tr><td></td><td></td><td>73</td><td></td><td>32</td><td></td><td>28</td><td>26</td><td></td><td>23</td><td></td><td>21</td><td>19</td><td>18</td><td></td><td></td></tr> <tr><td></td><td></td><td></td><td></td><td>16</td><td></td><td>12</td><td>10</td><td>8</td><td></td><td>5</td><td>3</td><td></td><td></td><td></td><td></td></tr> </table>			69				63						56	55	54	53	52	51	49				44	43	42	41				36	35	34	33			73		32		28	26		23		21	19	18							16		12	10	8		5	3																					
		69				63						56	55	54	53																																																																										
52	51	49				44	43	42	41				36	35	34	33																																																																									
		73		32		28	26		23		21	19	18																																																																												
				16		12	10	8		5	3																																																																														
AVAILABLE	NOT APPLICABLE	34566-2013	G	0	A	BLACK	<table border="1"> <tr><td></td><td>71</td><td>70</td><td></td><td></td><td></td><td>65</td><td></td><td></td><td></td><td></td><td>60</td><td>59</td><td>58</td><td>57</td><td></td><td>54</td><td>53</td></tr> <tr><td></td><td>51</td><td>50</td><td>49</td><td>48</td><td>46</td><td>45</td><td>43</td><td>41</td><td>40</td><td>39</td><td></td><td>37</td><td>36</td><td>35</td><td></td><td>33</td><td></td></tr> <tr><td></td><td></td><td></td><td>73</td><td></td><td>32</td><td>31</td><td>30</td><td></td><td></td><td></td><td>24</td><td>23</td><td>22</td><td></td><td>20</td><td></td><td></td></tr> <tr><td></td><td></td><td></td><td></td><td></td><td>16</td><td>15</td><td>13</td><td>12</td><td>11</td><td>10</td><td>9</td><td>8</td><td>7</td><td>6</td><td>5</td><td>4</td><td></td></tr> </table>		71	70				65					60	59	58	57		54	53		51	50	49	48	46	45	43	41	40	39		37	36	35		33					73		32	31	30				24	23	22		20								16	15	13	12	11	10	9	8	7	6	5	4											
	71	70				65					60	59	58	57		54	53																																																																								
	51	50	49	48	46	45	43	41	40	39		37	36	35		33																																																																									
			73		32	31	30				24	23	22		20																																																																										
					16	15	13	12	11	10	9	8	7	6	5	4																																																																									
AVAILABLE	NOT APPLICABLE	34566-2023	G	0	A	BLACK	<table border="1"> <tr><td></td><td></td><td>70</td><td>68</td><td>67</td><td>66</td><td>65</td><td></td><td></td><td></td><td></td><td></td><td></td><td>58</td><td>57</td><td></td><td>55</td><td></td></tr> <tr><td></td><td></td><td></td><td>49</td><td></td><td>47</td><td></td><td>44</td><td>43</td><td>42</td><td>41</td><td></td><td>39</td><td></td><td>37</td><td></td><td>35</td><td></td></tr> <tr><td></td><td></td><td></td><td></td><td>73</td><td></td><td>32</td><td></td><td>30</td><td></td><td></td><td>27</td><td>25</td><td>24</td><td></td><td>21</td><td>20</td><td>19</td><td>18</td><td>17</td></tr> <tr><td></td><td></td><td></td><td></td><td></td><td></td><td>15</td><td></td><td>13</td><td></td><td></td><td>9</td><td>8</td><td></td><td>6</td><td>5</td><td></td><td>3</td><td></td><td>1</td></tr> </table>			70	68	67	66	65							58	57		55					49		47		44	43	42	41		39		37		35						73		32		30			27	25	24		21	20	19	18	17							15		13			9	8		6	5		3		1						
		70	68	67	66	65							58	57		55																																																																									
			49		47		44	43	42	41		39		37		35																																																																									
				73		32		30			27	25	24		21	20	19	18	17																																																																						
						15		13			9	8		6	5		3		1																																																																						
AVAILABLE	NOT APPLICABLE	34566-2033	G	0	A	BLACK	<table border="1"> <tr><td></td><td>71</td><td>70</td><td></td><td></td><td></td><td>65</td><td>64</td><td></td><td></td><td></td><td>60</td><td>59</td><td>58</td><td>57</td><td></td><td>55</td><td>54</td><td>53</td></tr> <tr><td></td><td>51</td><td>50</td><td>49</td><td>48</td><td>46</td><td>45</td><td>43</td><td>41</td><td>40</td><td>39</td><td></td><td>37</td><td>36</td><td>35</td><td></td><td>33</td><td></td><td></td></tr> <tr><td></td><td></td><td></td><td>73</td><td></td><td>32</td><td>31</td><td>30</td><td></td><td></td><td></td><td>24</td><td>23</td><td>22</td><td></td><td>20</td><td></td><td></td><td></td></tr> <tr><td></td><td></td><td></td><td></td><td></td><td>16</td><td>15</td><td>13</td><td>12</td><td>11</td><td>10</td><td>9</td><td>8</td><td>7</td><td>6</td><td>5</td><td>4</td><td>3</td><td>2</td><td>1</td></tr> </table>		71	70				65	64				60	59	58	57		55	54	53		51	50	49	48	46	45	43	41	40	39		37	36	35		33						73		32	31	30				24	23	22		20									16	15	13	12	11	10	9	8	7	6	5	4	3	2	1					
	71	70				65	64				60	59	58	57		55	54	53																																																																							
	51	50	49	48	46	45	43	41	40	39		37	36	35		33																																																																									
			73		32	31	30				24	23	22		20																																																																										
					16	15	13	12	11	10	9	8	7	6	5	4	3	2	1																																																																						
AVAILABLE	NOT APPLICABLE	34566-2043	G	0	A	BLACK	<table border="1"> <tr><td></td><td></td><td>70</td><td></td><td>67</td><td>66</td><td>65</td><td></td><td></td><td></td><td></td><td></td><td></td><td>58</td><td>57</td><td></td><td>55</td><td></td><td></td></tr> <tr><td></td><td></td><td></td><td>49</td><td></td><td>47</td><td></td><td>44</td><td>43</td><td>42</td><td>41</td><td></td><td>39</td><td></td><td>37</td><td></td><td>35</td><td></td><td></td></tr> <tr><td></td><td></td><td></td><td></td><td>73</td><td></td><td>32</td><td></td><td>30</td><td></td><td></td><td>27</td><td>25</td><td>24</td><td></td><td>21</td><td>20</td><td>19</td><td>18</td><td>17</td></tr> <tr><td></td><td></td><td></td><td></td><td></td><td></td><td>15</td><td></td><td>13</td><td></td><td></td><td>9</td><td>8</td><td></td><td>6</td><td>5</td><td></td><td>3</td><td></td><td>1</td></tr> </table>			70		67	66	65							58	57		55						49		47		44	43	42	41		39		37		35							73		32		30			27	25	24		21	20	19	18	17							15		13			9	8		6	5		3		1				
		70		67	66	65							58	57		55																																																																									
			49		47		44	43	42	41		39		37		35																																																																									
				73		32		30			27	25	24		21	20	19	18	17																																																																						
						15		13			9	8		6	5		3		1																																																																						
AVAILABLE	NOT APPLICABLE	34566-2053	G	0	B	ST GRAY	<table border="1"> <tr><td></td><td></td><td>70</td><td>68</td><td>67</td><td>66</td><td>65</td><td></td><td></td><td></td><td></td><td></td><td></td><td>58</td><td>57</td><td></td><td>55</td><td></td><td></td></tr> <tr><td></td><td></td><td></td><td>49</td><td></td><td>47</td><td></td><td>44</td><td>43</td><td>42</td><td>41</td><td></td><td>39</td><td></td><td>37</td><td></td><td>35</td><td></td><td></td></tr> <tr><td></td><td></td><td></td><td></td><td>73</td><td></td><td>32</td><td></td><td>30</td><td></td><td></td><td>27</td><td>25</td><td>24</td><td>23</td><td>21</td><td>20</td><td>19</td><td>18</td><td>17</td></tr> <tr><td></td><td></td><td></td><td></td><td></td><td></td><td></td><td></td><td>13</td><td></td><td></td><td>8</td><td></td><td>6</td><td>5</td><td></td><td>3</td><td></td><td>1</td><td></td></tr> </table>			70	68	67	66	65							58	57		55						49		47		44	43	42	41		39		37		35							73		32		30			27	25	24	23	21	20	19	18	17									13			8		6	5		3		1					
		70	68	67	66	65							58	57		55																																																																									
			49		47		44	43	42	41		39		37		35																																																																									
				73		32		30			27	25	24	23	21	20	19	18	17																																																																						
								13			8		6	5		3		1																																																																							
AVAILABLE	NOT APPLICABLE	34566-2063	G	0	H	ST GRAY	<table border="1"> <tr><td></td><td></td><td></td><td>78</td><td></td><td></td><td></td><td></td><td></td><td>72</td><td>71</td><td>70</td><td>69</td><td>68</td><td></td><td>66</td><td>65</td><td>64</td><td>63</td><td>61</td></tr> <tr><td></td><td></td><td></td><td>58</td><td>57</td><td>56</td><td></td><td></td><td>53</td><td>52</td><td>51</td><td>50</td><td></td><td></td><td></td><td></td><td></td><td>44</td><td>43</td><td>41</td></tr> <tr><td></td><td></td><td></td><td>40</td><td></td><td>37</td><td>35</td><td>34</td><td></td><td>32</td><td>30</td><td>29</td><td></td><td>27</td><td>26</td><td></td><td></td><td></td><td></td><td>22</td><td>21</td></tr> <tr><td></td><td></td><td></td><td>20</td><td>19</td><td>18</td><td>17</td><td>16</td><td></td><td>14</td><td>12</td><td>10</td><td>9</td><td>8</td><td></td><td>6</td><td>5</td><td></td><td>3</td><td>2</td><td>1</td></tr> </table>				78						72	71	70	69	68		66	65	64	63	61				58	57	56			53	52	51	50						44	43	41				40		37	35	34		32	30	29		27	26					22	21				20	19	18	17	16		14	12	10	9	8		6	5		3	2	1
			78						72	71	70	69	68		66	65	64	63	61																																																																						
			58	57	56			53	52	51	50						44	43	41																																																																						
			40		37	35	34		32	30	29		27	26					22	21																																																																					
			20	19	18	17	16		14	12	10	9	8		6	5		3	2	1																																																																					
AVAILABLE	NOT APPLICABLE	34566-2073	G	0	H	ST GRAY	<table border="1"> <tr><td></td><td></td><td></td><td>78</td><td></td><td></td><td></td><td></td><td></td><td>72</td><td>71</td><td>70</td><td>69</td><td>68</td><td></td><td>66</td><td>65</td><td>64</td><td>63</td><td>61</td></tr> <tr><td></td><td></td><td></td><td>58</td><td>57</td><td>56</td><td></td><td></td><td>53</td><td>52</td><td>51</td><td>50</td><td></td><td></td><td></td><td></td><td></td><td>44</td><td>43</td><td>41</td></tr> <tr><td></td><td></td><td></td><td>40</td><td></td><td>37</td><td>35</td><td>34</td><td></td><td>32</td><td>30</td><td>29</td><td></td><td>27</td><td>26</td><td></td><td></td><td></td><td></td><td>22</td><td>21</td></tr> <tr><td></td><td></td><td></td><td>20</td><td>19</td><td>18</td><td>17</td><td>16</td><td></td><td>12</td><td></td><td></td><td>8</td><td></td><td>6</td><td>5</td><td></td><td>3</td><td>2</td><td>1</td><td></td></tr> </table>				78						72	71	70	69	68		66	65	64	63	61				58	57	56			53	52	51	50						44	43	41				40		37	35	34		32	30	29		27	26					22	21				20	19	18	17	16		12			8		6	5		3	2	1	
			78						72	71	70	69	68		66	65	64	63	61																																																																						
			58	57	56			53	52	51	50						44	43	41																																																																						
			40		37	35	34		32	30	29		27	26					22	21																																																																					
			20	19	18	17	16		12			8		6	5		3	2	1																																																																						
AVAILABLE	NOT APPLICABLE	34566-2083	G	0	H	ST GRAY	<table border="1"> <tr><td></td><td></td><td></td><td>78</td><td></td><td></td><td></td><td></td><td></td><td>72</td><td>71</td><td>70</td><td>69</td><td>68</td><td>67</td><td>66</td><td>65</td><td>64</td><td>63</td><td>61</td></tr> <tr><td></td><td></td><td></td><td>58</td><td>57</td><td>56</td><td></td><td></td><td>53</td><td>52</td><td>51</td><td>50</td><td></td><td></td><td></td><td></td><td></td><td>44</td><td>43</td><td>41</td></tr> <tr><td></td><td></td><td></td><td>40</td><td></td><td>37</td><td>35</td><td>34</td><td></td><td>32</td><td>30</td><td>29</td><td></td><td>27</td><td>26</td><td></td><td></td><td></td><td></td><td>22</td><td>21</td></tr> <tr><td></td><td></td><td></td><td>20</td><td>19</td><td>18</td><td>17</td><td>16</td><td></td><td>12</td><td></td><td></td><td>8</td><td>7</td><td>6</td><td>5</td><td></td><td>3</td><td>2</td><td>1</td><td></td></tr> </table>				78						72	71	70	69	68	67	66	65	64	63	61				58	57	56			53	52	51	50						44	43	41				40		37	35	34		32	30	29		27	26					22	21				20	19	18	17	16		12			8	7	6	5		3	2	1	
			78						72	71	70	69	68	67	66	65	64	63	61																																																																						
			58	57	56			53	52	51	50						44	43	41																																																																						
			40		37	35	34		32	30	29		27	26					22	21																																																																					
			20	19	18	17	16		12			8	7	6	5		3	2	1																																																																						

ENTER DESCRIPTION IEC NO: UAU2014-0376 DRAWN BY: CHYK DATE: 2013/09/05 APPR: IKOSHY DESCRIPTION: 2013/09/06 REV: 05	QUALITY SYMBOLS ∇=0 ∇=0 ∇=0	GENERAL TOLERANCES (UNLESS SPECIFIED) mm INCH 4 PLACES ± --- ± --- 3 PLACES ± --- ± --- 2 PLACES ± --- ± --- 1 PLACE ± --- ± --- 0 PLACE ± --- ± --- ANGULAR ± ---° DRAFT WHERE APPLICABLE MUST REMAIN WITHIN DIMENSIONS	DIMENSION STYLE MM ONLY DRAWN BY: SKRA JENDRANA DATE: 2011/02/14 CHECKED BY: MYANSLAMBROU DATE: 2011/02/14 APPROVED BY:	SCALE: METRIC DESIGN UNITS: METRIC THIRD ANGLE PROJECTION	TITLE: MX123 66/73/80CKT HRNS CONN ASSY molex	MATERIAL NO.: SD-34566-001 DOCUMENT NO.: SHEET NO.: 25 OF 68
	SEE BOM TABLE			THIS DRAWING CONTAINS INFORMATION THAT IS PROPRIETARY TO MOLEX INCORPORATED AND SHOULD NOT BE USED WITHOUT WRITTEN PERMISSION		

STATUS	GM PART #	MATERIAL #	PART/MATERIAL REVISION	WIRE DRESS OPTION	KEY OPTION	COLOR (TPA)	NUMBERS INDICATE CAVITIES OPEN FOR CIRCUITS																																																																																																																																																						
AVAILABLE	NOT APPLICABLE	34566-2093	G	0	A	BLACK	<table border="1"> <tr><td></td><td></td><td></td><td></td><td></td><td></td><td></td><td></td><td></td><td>68</td><td></td><td></td><td>65</td><td></td><td>63</td><td></td><td>61</td><td></td><td>59</td><td>58</td><td></td><td>56</td><td></td><td></td><td></td><td></td><td></td></tr> <tr><td>52</td><td></td><td>50</td><td></td><td></td><td></td><td></td><td></td><td></td><td>47</td><td></td><td></td><td></td><td></td><td></td><td></td><td></td><td></td><td>41</td><td></td><td></td><td>38</td><td>37</td><td>36</td><td></td><td>34</td><td>33</td></tr> <tr><td colspan="2"></td><td colspan="2">73</td><td colspan="2"></td><td colspan="2"></td><td colspan="2">32</td><td colspan="2">31</td><td colspan="2">30</td><td colspan="2">29</td><td colspan="2">28</td><td colspan="2">27</td><td colspan="2">25</td><td colspan="2">24</td><td colspan="2">23</td></tr> <tr><td colspan="2"></td><td colspan="2"></td><td colspan="2">16</td><td colspan="2"></td><td colspan="2"></td><td colspan="2">13</td><td colspan="2">12</td><td colspan="2">11</td><td colspan="2">10</td><td colspan="2">9</td><td colspan="2"></td><td colspan="2"></td><td colspan="2">1</td></tr> </table>										68			65		63		61		59	58		56						52		50							47									41			38	37	36		34	33			73						32		31		30		29		28		27		25		24		23						16						13		12		11		10		9						1																																													
									68			65		63		61		59	58		56																																																																																																																																								
52		50							47									41			38	37	36		34	33																																																																																																																																			
		73						32		31		30		29		28		27		25		24		23																																																																																																																																					
				16						13		12		11		10		9						1																																																																																																																																					
AVAILABLE	NOT APPLICABLE	34566-2113	G	0	H	ST GRY	<table border="1"> <tr><td></td><td></td><td></td><td></td><td></td><td></td><td></td><td></td><td></td><td></td><td></td><td></td><td></td><td></td><td></td><td></td><td></td><td></td><td></td><td></td><td></td><td></td><td></td><td></td><td></td><td></td><td></td><td></td><td></td></tr> <tr><td>79</td><td>78</td><td>77</td><td>76</td><td>75</td><td>74</td><td>73</td><td>72</td><td>71</td><td>70</td><td>69</td><td>68</td><td></td><td>66</td><td>65</td><td>64</td><td>63</td><td></td><td>61</td><td></td><td></td><td></td><td></td><td></td><td></td><td></td><td></td><td></td><td></td></tr> <tr><td>60</td><td>59</td><td>58</td><td>57</td><td>56</td><td>55</td><td></td><td>53</td><td>52</td><td></td><td>50</td><td></td><td></td><td></td><td></td><td></td><td></td><td></td><td></td><td></td><td></td><td>44</td><td>43</td><td>42</td><td>41</td><td></td><td></td><td></td><td></td></tr> <tr><td>40</td><td>39</td><td>38</td><td>37</td><td></td><td>35</td><td>34</td><td>33</td><td>32</td><td></td><td>30</td><td>29</td><td></td><td>27</td><td>26</td><td></td><td></td><td></td><td></td><td></td><td></td><td></td><td></td><td></td><td></td><td>22</td><td>21</td><td></td><td></td></tr> <tr><td>20</td><td>19</td><td>18</td><td>17</td><td>16</td><td></td><td>14</td><td>13</td><td>12</td><td>11</td><td>10</td><td>9</td><td>8</td><td>6</td><td>5</td><td></td><td>3</td><td>2</td><td></td><td></td><td></td><td></td><td></td><td></td><td></td><td></td><td></td><td></td><td></td></tr> </table>																														79	78	77	76	75	74	73	72	71	70	69	68		66	65	64	63		61											60	59	58	57	56	55		53	52		50											44	43	42	41					40	39	38	37		35	34	33	32		30	29		27	26											22	21			20	19	18	17	16		14	13	12	11	10	9	8	6	5		3	2																
79	78	77	76	75	74	73	72	71	70	69	68		66	65	64	63		61																																																																																																																																											
60	59	58	57	56	55		53	52		50											44	43	42	41																																																																																																																																					
40	39	38	37		35	34	33	32		30	29		27	26											22	21																																																																																																																																			
20	19	18	17	16		14	13	12	11	10	9	8	6	5		3	2																																																																																																																																												
AVAILABLE	NOT APPLICABLE	34566-2123	G	0	H	ST GRY	<table border="1"> <tr><td></td><td></td><td></td><td></td><td></td><td></td><td></td><td></td><td></td><td></td><td></td><td></td><td></td><td></td><td></td><td></td><td></td><td></td><td></td><td></td><td></td><td></td><td></td><td></td><td></td><td></td><td></td><td></td><td></td><td></td></tr> <tr><td>79</td><td>78</td><td>77</td><td>76</td><td>75</td><td>74</td><td>73</td><td>72</td><td>71</td><td>70</td><td>69</td><td>68</td><td></td><td>66</td><td>65</td><td>64</td><td>63</td><td></td><td>61</td><td></td><td></td><td></td><td></td><td></td><td></td><td></td><td></td><td></td><td></td><td></td></tr> <tr><td>60</td><td>59</td><td>58</td><td>57</td><td>56</td><td>55</td><td></td><td>53</td><td>52</td><td></td><td>50</td><td></td><td></td><td></td><td></td><td></td><td></td><td></td><td></td><td></td><td></td><td>44</td><td>43</td><td>42</td><td>41</td><td></td><td></td><td></td><td></td></tr> <tr><td>40</td><td>39</td><td>38</td><td>37</td><td></td><td>35</td><td>34</td><td>33</td><td>32</td><td></td><td>30</td><td>29</td><td></td><td>27</td><td>26</td><td></td><td></td><td></td><td></td><td></td><td></td><td></td><td></td><td></td><td></td><td>22</td><td>21</td><td></td><td></td></tr> <tr><td>20</td><td>19</td><td>18</td><td>17</td><td>16</td><td></td><td></td><td>13</td><td>12</td><td></td><td></td><td></td><td></td><td>8</td><td>6</td><td>5</td><td></td><td>3</td><td>2</td><td></td><td></td><td></td><td></td><td></td><td></td><td></td><td></td><td></td><td></td><td></td></tr> </table>																															79	78	77	76	75	74	73	72	71	70	69	68		66	65	64	63		61												60	59	58	57	56	55		53	52		50											44	43	42	41					40	39	38	37		35	34	33	32		30	29		27	26											22	21			20	19	18	17	16			13	12					8	6	5		3	2													
79	78	77	76	75	74	73	72	71	70	69	68		66	65	64	63		61																																																																																																																																											
60	59	58	57	56	55		53	52		50											44	43	42	41																																																																																																																																					
40	39	38	37		35	34	33	32		30	29		27	26											22	21																																																																																																																																			
20	19	18	17	16			13	12					8	6	5		3	2																																																																																																																																											
AVAILABLE	NOT APPLICABLE	34566-2133	G	0	B	ST GRY	<table border="1"> <tr><td></td><td></td><td></td><td></td><td></td><td></td><td></td><td></td><td></td><td></td><td></td><td></td><td></td><td></td><td></td><td></td><td></td><td></td><td></td><td></td><td></td><td></td><td></td><td></td><td></td><td></td><td></td><td></td><td></td><td></td></tr> <tr><td>71</td><td>70</td><td></td><td></td><td></td><td></td><td></td><td></td><td></td><td></td><td></td><td></td><td></td><td></td><td></td><td></td><td></td><td></td><td></td><td></td><td></td><td></td><td></td><td></td><td></td><td></td><td></td><td></td><td></td><td></td></tr> <tr><td>51</td><td>50</td><td>49</td><td>48</td><td>46</td><td>45</td><td></td><td></td><td>43</td><td></td><td>41</td><td>40</td><td>39</td><td></td><td>37</td><td>36</td><td>35</td><td></td><td></td><td></td><td></td><td></td><td></td><td></td><td></td><td></td><td></td><td></td><td></td><td></td></tr> <tr><td colspan="2"></td><td colspan="2">73</td><td colspan="2"></td><td colspan="2"></td><td colspan="2">32</td><td colspan="2">31</td><td colspan="2">30</td><td colspan="2"></td><td colspan="2">24</td><td colspan="2">23</td><td colspan="2">22</td><td colspan="2">20</td><td colspan="2"></td><td colspan="2"></td><td colspan="2"></td></tr> <tr><td colspan="2"></td><td colspan="2"></td><td colspan="2">16</td><td colspan="2">15</td><td colspan="2">13</td><td colspan="2">12</td><td colspan="2">11</td><td colspan="2">10</td><td colspan="2">9</td><td colspan="2">8</td><td colspan="2">7</td><td colspan="2">6</td><td colspan="2">5</td><td colspan="2">4</td><td colspan="2">3</td></tr> </table>																															71	70																													51	50	49	48	46	45			43		41	40	39		37	36	35																73						32		31		30				24		23		22		20												16		15		13		12		11		10		9		8		7		6		5		4		3	
71	70																																																																																																																																																												
51	50	49	48	46	45			43		41	40	39		37	36	35																																																																																																																																													
		73						32		31		30				24		23		22		20																																																																																																																																							
				16		15		13		12		11		10		9		8		7		6		5		4		3																																																																																																																																	
AVAILABLE	NOT APPLICABLE	34566-2143	G	0	B	ST GRY	<table border="1"> <tr><td></td><td></td><td></td><td></td><td></td><td></td><td></td><td></td><td></td><td></td><td></td><td></td><td></td><td></td><td></td><td></td><td></td><td></td><td></td><td></td><td></td><td></td><td></td><td></td><td></td><td></td><td></td><td></td><td></td><td></td></tr> <tr><td>71</td><td>70</td><td></td><td></td><td></td><td></td><td></td><td></td><td></td><td></td><td></td><td></td><td></td><td></td><td></td><td></td><td></td><td></td><td></td><td></td><td></td><td></td><td></td><td></td><td></td><td></td><td></td><td></td><td></td><td></td></tr> <tr><td>51</td><td>50</td><td>49</td><td>48</td><td>46</td><td>45</td><td></td><td></td><td>43</td><td></td><td>41</td><td>40</td><td>39</td><td></td><td>37</td><td>36</td><td>35</td><td></td><td></td><td></td><td></td><td></td><td></td><td></td><td></td><td></td><td></td><td></td><td></td><td></td></tr> <tr><td colspan="2"></td><td colspan="2">73</td><td colspan="2"></td><td colspan="2"></td><td colspan="2">32</td><td colspan="2">31</td><td colspan="2">30</td><td colspan="2"></td><td colspan="2">24</td><td colspan="2">23</td><td colspan="2">22</td><td colspan="2">20</td><td colspan="2"></td><td colspan="2"></td><td colspan="2"></td></tr> <tr><td colspan="2"></td><td colspan="2"></td><td colspan="2">16</td><td colspan="2">15</td><td colspan="2">13</td><td colspan="2">12</td><td colspan="2">11</td><td colspan="2">10</td><td colspan="2">9</td><td colspan="2">8</td><td colspan="2">7</td><td colspan="2">6</td><td colspan="2">5</td><td colspan="2">4</td><td colspan="2">3</td></tr> </table>																															71	70																													51	50	49	48	46	45			43		41	40	39		37	36	35																73						32		31		30				24		23		22		20												16		15		13		12		11		10		9		8		7		6		5		4		3	
71	70																																																																																																																																																												
51	50	49	48	46	45			43		41	40	39		37	36	35																																																																																																																																													
		73						32		31		30				24		23		22		20																																																																																																																																							
				16		15		13		12		11		10		9		8		7		6		5		4		3																																																																																																																																	
AVAILABLE	NOT APPLICABLE	34566-2153	G	0	A	BLACK	<table border="1"> <tr><td></td><td></td><td></td><td></td><td></td><td></td><td></td><td></td><td></td><td></td><td></td><td></td><td></td><td></td><td></td><td></td><td></td><td></td><td></td><td></td><td></td><td></td><td></td><td></td><td></td><td></td><td></td><td></td><td></td><td></td></tr> <tr><td></td><td></td><td></td><td></td><td></td><td></td><td></td><td></td><td></td><td></td><td></td><td></td><td></td><td></td><td></td><td></td><td></td><td></td><td></td><td></td><td></td><td></td><td></td><td></td><td></td><td></td><td></td><td></td><td></td><td></td></tr> <tr><td></td><td></td><td></td><td></td><td></td><td></td><td></td><td></td><td></td><td></td><td></td><td></td><td></td><td></td><td></td><td></td><td></td><td></td><td></td><td></td><td></td><td></td><td></td><td></td><td></td><td></td><td></td><td></td><td></td><td></td></tr> <tr><td></td><td></td><td></td><td></td><td></td><td></td><td></td><td></td><td></td><td></td><td></td><td></td><td></td><td></td><td></td><td></td><td></td><td></td><td></td><td></td><td></td><td></td><td></td><td></td><td></td><td></td><td></td><td></td><td></td><td></td></tr> <tr><td></td><td></td><td></td><td></td><td></td><td></td><td></td><td></td><td></td><td></td><td></td><td></td><td></td><td></td><td></td><td></td><td></td><td></td><td></td><td></td><td></td><td></td><td></td><td></td><td></td><td></td><td></td><td></td><td></td><td></td></tr> </table>																																																																																																																																																						
AVAILABLE	NOT APPLICABLE	34566-2163	G	0	A	BLACK	<table border="1"> <tr><td></td><td></td><td></td><td></td><td></td><td></td><td></td><td></td><td></td><td></td><td></td><td></td><td></td><td></td><td></td><td></td><td></td><td></td><td></td><td></td><td></td><td></td><td></td><td></td><td></td><td></td><td></td><td></td><td></td><td></td></tr> <tr><td></td><td></td><td></td><td></td><td></td><td></td><td></td><td></td><td></td><td></td><td></td><td></td><td></td><td></td><td></td><td></td><td></td><td></td><td></td><td></td><td></td><td></td><td></td><td></td><td></td><td></td><td></td><td></td><td></td><td></td></tr> <tr><td></td><td></td><td></td><td></td><td></td><td></td><td></td><td></td><td></td><td></td><td></td><td></td><td></td><td></td><td></td><td></td><td></td><td></td><td></td><td></td><td></td><td></td><td></td><td></td><td></td><td></td><td></td><td></td><td></td><td></td></tr> <tr><td></td><td></td><td></td><td></td><td></td><td></td><td></td><td></td><td></td><td></td><td></td><td></td><td></td><td></td><td></td><td></td><td></td><td></td><td></td><td></td><td></td><td></td><td></td><td></td><td></td><td></td><td></td><td></td><td></td><td></td></tr> <tr><td></td><td></td><td></td><td></td><td></td><td></td><td></td><td></td><td></td><td></td><td></td><td></td><td></td><td></td><td></td><td></td><td></td><td></td><td></td><td></td><td></td><td></td><td></td><td></td><td></td><td></td><td></td><td></td><td></td><td></td></tr> </table>																																																																																																																																																						
AVAILABLE	NOT APPLICABLE	34566-2173	G	0	A	BLACK	<table border="1"> <tr><td></td><td></td><td></td><td></td><td></td><td></td><td></td><td></td><td></td><td></td><td></td><td></td><td></td><td></td><td></td><td></td><td></td><td></td><td></td><td></td><td></td><td></td><td></td><td></td><td></td><td></td><td></td><td></td><td></td><td></td></tr> <tr><td></td><td></td><td></td><td></td><td></td><td></td><td></td><td></td><td></td><td></td><td></td><td></td><td></td><td></td><td></td><td></td><td></td><td></td><td></td><td></td><td></td><td></td><td></td><td></td><td></td><td></td><td></td><td></td><td></td><td></td></tr> <tr><td></td><td></td><td></td><td></td><td></td><td></td><td></td><td></td><td></td><td></td><td></td><td></td><td></td><td></td><td></td><td></td><td></td><td></td><td></td><td></td><td></td><td></td><td></td><td></td><td></td><td></td><td></td><td></td><td></td><td></td></tr> <tr><td></td><td></td><td></td><td></td><td></td><td></td><td></td><td></td><td></td><td></td><td></td><td></td><td></td><td></td><td></td><td></td><td></td><td></td><td></td><td></td><td></td><td></td><td></td><td></td><td></td><td></td><td></td><td></td><td></td><td></td></tr> <tr><td></td><td></td><td></td><td></td><td></td><td></td><td></td><td></td><td></td><td></td><td></td><td></td><td></td><td></td><td></td><td></td><td></td><td></td><td></td><td></td><td></td><td></td><td></td><td></td><td></td><td></td><td></td><td></td><td></td><td></td></tr> </table>																																																																																																																																																						
AVAILABLE	NOT APPLICABLE	34566-2183	G	0	A	BLACK	<table border="1"> <tr><td></td><td></td><td></td><td></td><td></td><td></td><td></td><td></td><td></td><td></td><td></td><td></td><td></td><td></td><td></td><td></td><td></td><td></td><td></td><td></td><td></td><td></td><td></td><td></td><td></td><td></td><td></td><td></td><td></td><td></td></tr> <tr><td></td><td></td><td></td><td></td><td></td><td></td><td></td><td></td><td></td><td></td><td></td><td></td><td></td><td></td><td></td><td></td><td></td><td></td><td></td><td></td><td></td><td></td><td></td><td></td><td></td><td></td><td></td><td></td><td></td><td></td></tr> <tr><td></td><td></td><td></td><td></td><td></td><td></td><td></td><td></td><td></td><td></td><td></td><td></td><td></td><td></td><td></td><td></td><td></td><td></td><td></td><td></td><td></td><td></td><td></td><td></td><td></td><td></td><td></td><td></td><td></td><td></td></tr> <tr><td></td><td></td><td></td><td></td><td></td><td></td><td></td><td></td><td></td><td></td><td></td><td></td><td></td><td></td><td></td><td></td><td></td><td></td><td></td><td></td><td></td><td></td><td></td><td></td><td></td><td></td><td></td><td></td><td></td><td></td></tr> <tr><td></td><td></td><td></td><td></td><td></td><td></td><td></td><td></td><td></td><td></td><td></td><td></td><td></td><td></td><td></td><td></td><td></td><td></td><td></td><td></td><td></td><td></td><td></td><td></td><td></td><td></td><td></td><td></td><td></td><td></td></tr> </table>																																																																																																																																																						

ENTER DESCRIPTION IEC NO: UAU2014-0376 DRAWN BY: CHIKO APPROV: IKOSHY REV: 05 2013/09/06	QUALITY SYMBOLS	GENERAL TOLERANCES (UNLESS SPECIFIED)	DIMENSION STYLE	SCALE	DESIGN UNITS	THIRD ANGLE PROJECTION
	∇=0	4 PLACES ±--- ±---	MM ONLY		METRIC	
	∇=0	3 PLACES ±--- ±---	DRAWN BY: SKRAJENDRANA	DATE: 2011/02/14	TITLE: MX123 66/73/80CKT HRNS CONN ASSY	
	∇=0	2 PLACES ±--- ±---	CHECKED BY: MYANSLAMBROU	DATE: 2011/02/14	APPROVED BY: [Signature]	
		ANGULAR ±---°	MATERIAL NO.	DOCUMENT NO.		
		DRAFT WHERE APPLICABLE MUST REMAIN WITHIN DIMENSIONS	SEE BOM TABLE	SD-34566-001		
			THIS DRAWING CONTAINS INFORMATION THAT IS PROPRIETARY TO MOLEX INCORPORATED AND SHOULD NOT BE USED WITHOUT WRITTEN PERMISSION			

STATUS	GM PART #	MATERIAL #	PART/MATERIAL REVISION	WIRE DRESS OPTION	KEY OPTION ▽	COLOR (TPA) ▽	NUMBERS INDICATE CAVITIES OPEN FOR CIRCUITS ▽																																																																																								
								AVAILABLE	NOT APPLICABLE	34566-2193	G	0	A	BLACK	<table border="1"> <tr><td></td><td>70</td><td></td><td>67</td><td>66</td><td>65</td><td></td><td></td><td></td><td></td><td></td><td></td><td></td><td>58</td><td>57</td><td>55</td><td></td><td></td></tr> <tr><td></td><td></td><td>49</td><td>47</td><td></td><td></td><td>44</td><td>43</td><td>42</td><td>41</td><td>39</td><td></td><td>37</td><td></td><td>20</td><td>19</td><td>18</td><td>17</td></tr> <tr><td>73</td><td></td><td></td><td>32</td><td>30</td><td></td><td></td><td></td><td>27</td><td>25</td><td>24</td><td></td><td></td><td>21</td><td>20</td><td>19</td><td>18</td><td>17</td></tr> <tr><td></td><td></td><td></td><td></td><td>15</td><td></td><td>13</td><td></td><td></td><td>9</td><td>8</td><td></td><td>6</td><td>5</td><td></td><td>3</td><td></td><td>1</td></tr> </table>		70		67	66	65								58	57	55					49	47			44	43	42	41	39		37		20	19	18	17	73			32	30				27	25	24			21	20	19	18	17					15		13			9	8		6	5		3		1								
	70		67	66	65								58	57	55																																																																																
		49	47			44	43	42	41	39		37		20	19	18	17																																																																														
73			32	30				27	25	24			21	20	19	18	17																																																																														
				15		13			9	8		6	5		3		1																																																																														
AVAILABLE	NOT APPLICABLE	34566-2213	G	9	H	ST GRAY	<table border="1"> <tr><td></td><td>79</td><td>78</td><td>77</td><td>76</td><td>75</td><td>74</td><td>73</td><td>72</td><td>71</td><td>70</td><td>69</td><td>68</td><td></td><td>66</td><td>65</td><td>64</td><td>63</td><td>61</td></tr> <tr><td>60</td><td>59</td><td>58</td><td>57</td><td>56</td><td></td><td></td><td></td><td>53</td><td></td><td>50</td><td></td><td></td><td></td><td></td><td></td><td>44</td><td>43</td><td>41</td></tr> <tr><td>40</td><td>39</td><td>38</td><td>37</td><td></td><td>35</td><td>34</td><td>33</td><td>32</td><td></td><td>30</td><td>29</td><td></td><td>27</td><td>26</td><td></td><td>24</td><td>23</td><td>22</td><td>21</td></tr> <tr><td>20</td><td>19</td><td>18</td><td>17</td><td></td><td></td><td>14</td><td>13</td><td>12</td><td>11</td><td>10</td><td>9</td><td>8</td><td></td><td>6</td><td>5</td><td></td><td>3</td><td>2</td><td></td></tr> </table>		79	78	77	76	75	74	73	72	71	70	69	68		66	65	64	63	61	60	59	58	57	56				53		50						44	43	41	40	39	38	37		35	34	33	32		30	29		27	26		24	23	22	21	20	19	18	17			14	13	12	11	10	9	8		6	5		3	2											
	79	78	77	76	75	74	73	72	71	70	69	68		66	65	64	63	61																																																																													
60	59	58	57	56				53		50						44	43	41																																																																													
40	39	38	37		35	34	33	32		30	29		27	26		24	23	22	21																																																																												
20	19	18	17			14	13	12	11	10	9	8		6	5		3	2																																																																													
AVAILABLE	NOT APPLICABLE	34566-2223	G	0	A	BLACK	<table border="1"> <tr><td>72</td><td>71</td><td>70</td><td>69</td><td>68</td><td>67</td><td>66</td><td></td><td>64</td><td>63</td><td>62</td><td></td><td>60</td><td>59</td><td></td><td></td><td></td><td>55</td><td>54</td><td>53</td></tr> <tr><td>52</td><td></td><td>49</td><td>48</td><td>46</td><td></td><td></td><td></td><td>44</td><td>43</td><td>42</td><td></td><td>40</td><td>39</td><td></td><td></td><td></td><td></td><td>35</td><td>34</td><td>33</td></tr> <tr><td></td><td></td><td></td><td></td><td></td><td></td><td></td><td></td><td></td><td></td><td>29</td><td></td><td>27</td><td></td><td>24</td><td>23</td><td></td><td></td><td>19</td><td>18</td><td>17</td></tr> <tr><td>73</td><td></td><td></td><td></td><td></td><td></td><td>16</td><td></td><td>14</td><td>13</td><td>12</td><td>11</td><td></td><td>9</td><td>8</td><td>7</td><td>6</td><td>5</td><td>4</td><td>3</td><td>2</td><td>1</td></tr> </table>	72	71	70	69	68	67	66		64	63	62		60	59				55	54	53	52		49	48	46				44	43	42		40	39					35	34	33											29		27		24	23			19	18	17	73						16		14	13	12	11		9	8	7	6	5	4	3	2	1				
72	71	70	69	68	67	66		64	63	62		60	59				55	54	53																																																																												
52		49	48	46				44	43	42		40	39					35	34	33																																																																											
										29		27		24	23			19	18	17																																																																											
73						16		14	13	12	11		9	8	7	6	5	4	3	2	1																																																																										
AVAILABLE	NOT APPLICABLE	34566-2233	G	0	A	BLACK	<table border="1"> <tr><td></td><td></td><td></td><td>69</td><td></td><td></td><td></td><td></td><td></td><td></td><td>63</td><td></td><td></td><td></td><td></td><td>58</td><td></td><td>56</td><td></td><td>54</td><td></td></tr> <tr><td>52</td><td>51</td><td></td><td>49</td><td></td><td></td><td></td><td></td><td></td><td></td><td>44</td><td>43</td><td>42</td><td>41</td><td></td><td></td><td></td><td></td><td>36</td><td>35</td><td>34</td><td>33</td></tr> <tr><td></td><td></td><td></td><td></td><td></td><td></td><td></td><td></td><td></td><td></td><td></td><td></td><td></td><td></td><td></td><td></td><td></td><td></td><td></td><td>19</td><td>18</td><td></td></tr> <tr><td>73</td><td></td><td></td><td></td><td></td><td></td><td>16</td><td></td><td></td><td></td><td>12</td><td></td><td>10</td><td></td><td></td><td></td><td></td><td></td><td></td><td>3</td><td></td><td></td></tr> </table>				69							63					58		56		54		52	51		49							44	43	42	41					36	35	34	33																				19	18		73						16				12		10							3			
			69							63					58		56		54																																																																												
52	51		49							44	43	42	41					36	35	34	33																																																																										
																			19	18																																																																											
73						16				12		10							3																																																																												
AVAILABLE	NOT APPLICABLE	34566-2243	G	0	H	ST GRAY	<table border="1"> <tr><td></td><td>79</td><td>78</td><td>77</td><td>76</td><td>75</td><td>74</td><td>73</td><td>72</td><td>71</td><td>70</td><td>69</td><td>68</td><td></td><td>66</td><td>65</td><td>64</td><td>63</td><td>61</td></tr> <tr><td>60</td><td>59</td><td>58</td><td>57</td><td>56</td><td></td><td></td><td></td><td>53</td><td>52</td><td></td><td>50</td><td></td><td></td><td></td><td></td><td>44</td><td>43</td><td>41</td></tr> <tr><td>40</td><td>39</td><td>38</td><td>37</td><td></td><td>35</td><td>34</td><td>33</td><td>32</td><td></td><td>30</td><td>29</td><td></td><td>27</td><td>26</td><td></td><td>24</td><td>23</td><td>22</td><td>21</td></tr> <tr><td>20</td><td>19</td><td>18</td><td>17</td><td></td><td></td><td>14</td><td>13</td><td>12</td><td>11</td><td>10</td><td>9</td><td>8</td><td></td><td>6</td><td>5</td><td></td><td>3</td><td>2</td><td></td></tr> </table>		79	78	77	76	75	74	73	72	71	70	69	68		66	65	64	63	61	60	59	58	57	56				53	52		50					44	43	41	40	39	38	37		35	34	33	32		30	29		27	26		24	23	22	21	20	19	18	17			14	13	12	11	10	9	8		6	5		3	2											
	79	78	77	76	75	74	73	72	71	70	69	68		66	65	64	63	61																																																																													
60	59	58	57	56				53	52		50					44	43	41																																																																													
40	39	38	37		35	34	33	32		30	29		27	26		24	23	22	21																																																																												
20	19	18	17			14	13	12	11	10	9	8		6	5		3	2																																																																													
AVAILABLE	NOT APPLICABLE	34566-2253	G	0	A	BLACK	<table border="1"> <tr><td>72</td><td>71</td><td>70</td><td>69</td><td>68</td><td></td><td>66</td><td>65</td><td>64</td><td>63</td><td></td><td>61</td><td></td><td>59</td><td>58</td><td></td><td>56</td><td></td><td>54</td><td>53</td></tr> <tr><td>52</td><td></td><td>50</td><td>49</td><td>47</td><td></td><td></td><td></td><td></td><td></td><td>42</td><td>41</td><td></td><td></td><td>38</td><td>37</td><td>36</td><td></td><td>34</td><td>33</td></tr> <tr><td></td><td></td><td></td><td></td><td></td><td></td><td></td><td></td><td></td><td></td><td></td><td></td><td></td><td></td><td></td><td></td><td></td><td></td><td>19</td><td>18</td><td>17</td></tr> <tr><td>73</td><td></td><td></td><td></td><td></td><td></td><td>16</td><td></td><td></td><td></td><td>13</td><td>12</td><td>11</td><td>10</td><td>9</td><td>8</td><td></td><td></td><td></td><td></td><td></td><td>1</td></tr> </table>	72	71	70	69	68		66	65	64	63		61		59	58		56		54	53	52		50	49	47						42	41			38	37	36		34	33																			19	18	17	73						16				13	12	11	10	9	8						1					
72	71	70	69	68		66	65	64	63		61		59	58		56		54	53																																																																												
52		50	49	47						42	41			38	37	36		34	33																																																																												
																		19	18	17																																																																											
73						16				13	12	11	10	9	8						1																																																																										
AVAILABLE	NOT APPLICABLE	34566-2263	G	0	A	BLACK	<table border="1"> <tr><td></td><td></td><td></td><td>69</td><td></td><td></td><td></td><td></td><td></td><td></td><td>63</td><td></td><td></td><td></td><td></td><td>58</td><td></td><td>56</td><td>55</td><td>54</td><td>53</td></tr> <tr><td>52</td><td>51</td><td>50</td><td>49</td><td></td><td></td><td></td><td></td><td></td><td></td><td>44</td><td>43</td><td>42</td><td>41</td><td></td><td></td><td></td><td></td><td>36</td><td>35</td><td>34</td><td>33</td></tr> <tr><td></td><td></td><td></td><td></td><td></td><td></td><td></td><td></td><td></td><td></td><td></td><td></td><td></td><td></td><td></td><td></td><td></td><td></td><td></td><td>19</td><td>18</td><td></td></tr> <tr><td>73</td><td></td><td></td><td></td><td></td><td></td><td>16</td><td></td><td>14</td><td></td><td>12</td><td></td><td>10</td><td></td><td></td><td></td><td></td><td></td><td></td><td>3</td><td></td><td></td></tr> </table>				69							63					58		56	55	54	53	52	51	50	49							44	43	42	41					36	35	34	33																				19	18		73						16		14		12		10							3			
			69							63					58		56	55	54	53																																																																											
52	51	50	49							44	43	42	41					36	35	34	33																																																																										
																			19	18																																																																											
73						16		14		12		10							3																																																																												
AVAILABLE	NOT APPLICABLE	34566-2273	G	0	A	BLACK	<table border="1"> <tr><td></td><td></td><td></td><td>69</td><td></td><td></td><td></td><td></td><td></td><td></td><td>63</td><td>62</td><td>61</td><td></td><td></td><td>58</td><td>57</td><td>56</td><td>55</td><td>54</td><td>53</td></tr> <tr><td>52</td><td>51</td><td>50</td><td>49</td><td></td><td></td><td></td><td></td><td></td><td></td><td>44</td><td>43</td><td>42</td><td>41</td><td></td><td></td><td>37</td><td>36</td><td>35</td><td>34</td><td>33</td></tr> <tr><td></td><td></td><td></td><td></td><td></td><td></td><td></td><td></td><td></td><td></td><td></td><td></td><td></td><td></td><td></td><td></td><td></td><td></td><td></td><td>19</td><td>18</td><td></td></tr> <tr><td>73</td><td></td><td></td><td></td><td></td><td></td><td>16</td><td></td><td>14</td><td>13</td><td>12</td><td>11</td><td>10</td><td></td><td></td><td></td><td></td><td></td><td></td><td>3</td><td></td><td></td></tr> </table>				69							63	62	61			58	57	56	55	54	53	52	51	50	49							44	43	42	41			37	36	35	34	33																				19	18		73						16		14	13	12	11	10							3				
			69							63	62	61			58	57	56	55	54	53																																																																											
52	51	50	49							44	43	42	41			37	36	35	34	33																																																																											
																			19	18																																																																											
73						16		14	13	12	11	10							3																																																																												
AVAILABLE	NOT APPLICABLE	34566-2283	G	0	B	ST. GRAY	<table border="1"> <tr><td></td><td></td><td></td><td></td><td>68</td><td>67</td><td>66</td><td></td><td>65</td><td>64</td><td>63</td><td></td><td></td><td></td><td></td><td></td><td></td><td></td><td></td><td>55</td><td></td><td></td></tr> <tr><td></td><td></td><td></td><td>49</td><td>48</td><td>46</td><td></td><td></td><td>45</td><td>44</td><td>43</td><td></td><td></td><td></td><td></td><td></td><td></td><td></td><td></td><td></td><td></td><td></td></tr> <tr><td></td><td></td><td></td><td></td><td></td><td></td><td></td><td></td><td></td><td></td><td></td><td></td><td></td><td></td><td></td><td></td><td></td><td></td><td></td><td></td><td></td><td>17</td></tr> <tr><td>73</td><td></td><td></td><td></td><td></td><td></td><td>16</td><td></td><td></td><td></td><td></td><td></td><td></td><td>10</td><td></td><td></td><td></td><td></td><td></td><td></td><td></td><td></td></tr> </table>					68	67	66		65	64	63									55						49	48	46			45	44	43																																	17	73						16							10								
				68	67	66		65	64	63									55																																																																												
			49	48	46			45	44	43																																																																																					
																					17																																																																										
73						16							10																																																																																		

ENTER DESCRIPTION ELEC NO: VALU2014-0376 DRAWN BY: DRWNTYE CHKD: APPR:WOSHY 2013/09/05 2013/09/06 REV: 65	QUALITY SYMBOLS ▽=0 ▽=0 ▽=0	GENERAL TOLERANCES (UNLESS SPECIFIED): mm INCH 4 PLACES ±--- ±--- 3 PLACES ±--- ±--- 2 PLACES ±--- ±--- 1 PLACE ±--- ±--- 0 PLACE ±--- ±--- ANGULAR ±---° DRAFT WHERE APPLICABLE MUST REMAIN WITHIN DIMENSIONS	DIMENSION STYLE MM ONLY	SCALE METRIC	DESIGN UNITS METRIC	THIRD ANGLE PROJECTION 	
	DRAWN BY: SKRAJENDRANA 2011/02/14 CHECKED BY: MVANSLAMBROU 2011/02/14 APPROVED BY:	DATE:	DATE:	DATE:	TITLE MX123 66/73/80CKT HRNS CONN ASSY	MATERIAL NO. SEE BOM TABLE	DOCUMENT NO. SD-34566-001

STATUS	GM PART #	MATERIAL #	PART/MATERIAL REVISION	WIRE DRESS OPTION	KEY OPTION	COLOR (TPA)	NUMBERS INDICATE CAVITIES OPEN FOR CIRCUITS																																																															
AVAILABLE	NOT APPLICABLE	34566-2293	G	0	C	BLUE	<table border="1"> <tr><td>72</td><td>70</td><td>68</td><td>66</td><td>63</td><td>59</td><td>57</td><td>53</td></tr> <tr><td>52</td><td>51</td><td>48</td><td>47</td><td>46</td><td>44</td><td>42</td><td>40</td><td>39</td><td>34</td><td>33</td></tr> <tr><td colspan="2">73</td><td>30</td><td>26</td><td>25</td><td>22</td><td>21</td><td></td><td></td><td></td><td></td></tr> <tr><td colspan="2"></td><td>15</td><td>14</td><td>10</td><td>9</td><td>6</td><td></td><td></td><td></td><td></td></tr> </table>	72	70	68	66	63	59	57	53	52	51	48	47	46	44	42	40	39	34	33	73		30	26	25	22	21							15	14	10	9	6																										
72	70	68	66	63	59	57	53																																																															
52	51	48	47	46	44	42	40	39	34	33																																																												
73		30	26	25	22	21																																																																
		15	14	10	9	6																																																																
AVAILABLE	NOT APPLICABLE	34566-2313	G	0	C	BLUE	<table border="1"> <tr><td>72</td><td>70</td><td>66</td><td>63</td><td>59</td><td>57</td><td>53</td></tr> <tr><td>52</td><td>51</td><td>46</td><td>44</td><td>42</td><td>40</td><td>39</td><td>34</td><td>33</td></tr> <tr><td colspan="2">73</td><td>30</td><td>26</td><td>25</td><td>22</td><td>21</td><td></td><td></td><td></td></tr> <tr><td colspan="2"></td><td>15</td><td>14</td><td>10</td><td>9</td><td>6</td><td></td><td></td><td></td></tr> </table>	72	70	66	63	59	57	53	52	51	46	44	42	40	39	34	33	73		30	26	25	22	21						15	14	10	9	6																														
72	70	66	63	59	57	53																																																																
52	51	46	44	42	40	39	34	33																																																														
73		30	26	25	22	21																																																																
		15	14	10	9	6																																																																
AVAILABLE	NOT APPLICABLE	34566-2323	G	0	C	BLUE	<table border="1"> <tr><td>72</td><td>70</td><td>68</td><td>66</td><td>63</td><td>59</td><td>57</td><td>53</td></tr> <tr><td>52</td><td>51</td><td>48</td><td>47</td><td>46</td><td>44</td><td>42</td><td>40</td><td>39</td><td>34</td><td>33</td></tr> <tr><td colspan="2">73</td><td>30</td><td>26</td><td>25</td><td>22</td><td>21</td><td>20</td><td></td><td></td><td></td></tr> <tr><td colspan="2"></td><td>15</td><td>14</td><td>10</td><td>9</td><td>6</td><td>5</td><td>4</td><td></td><td></td></tr> </table>	72	70	68	66	63	59	57	53	52	51	48	47	46	44	42	40	39	34	33	73		30	26	25	22	21	20						15	14	10	9	6	5	4																								
72	70	68	66	63	59	57	53																																																															
52	51	48	47	46	44	42	40	39	34	33																																																												
73		30	26	25	22	21	20																																																															
		15	14	10	9	6	5	4																																																														
AVAILABLE	NOT APPLICABLE	34566-2333	G	0	A	BLACK	<table border="1"> <tr><td>71</td><td>69</td><td>68</td><td>65</td><td>64</td><td>63</td><td>61</td><td>59</td><td>57</td><td>56</td><td>34</td><td>33</td></tr> <tr><td>52</td><td>50</td><td>49</td><td>47</td><td>46</td><td>44</td><td>42</td><td>41</td><td>39</td><td>38</td><td>37</td><td>36</td><td>34</td><td>33</td></tr> <tr><td colspan="2">73</td><td>32</td><td>31</td><td>30</td><td>29</td><td>28</td><td>27</td><td>24</td><td>23</td><td>22</td><td>20</td><td>19</td><td>18</td><td>1</td></tr> <tr><td colspan="2"></td><td>16</td><td>13</td><td>12</td><td>11</td><td>10</td><td>9</td><td></td><td></td><td></td><td></td><td></td><td></td><td></td></tr> </table>	71	69	68	65	64	63	61	59	57	56	34	33	52	50	49	47	46	44	42	41	39	38	37	36	34	33	73		32	31	30	29	28	27	24	23	22	20	19	18	1			16	13	12	11	10	9														
71	69	68	65	64	63	61	59	57	56	34	33																																																											
52	50	49	47	46	44	42	41	39	38	37	36	34	33																																																									
73		32	31	30	29	28	27	24	23	22	20	19	18	1																																																								
		16	13	12	11	10	9																																																															
AVAILABLE	NOT APPLICABLE	34566-2343	G	0	A	BLACK	<table border="1"> <tr><td>72</td><td>70</td><td>68</td><td>67</td><td>66</td><td>65</td><td>58</td><td>57</td><td>55</td><td></td><td></td><td></td></tr> <tr><td></td><td>49</td><td>47</td><td>44</td><td>43</td><td>42</td><td>41</td><td>39</td><td>37</td><td>35</td><td></td><td></td></tr> <tr><td colspan="2">73</td><td>32</td><td>30</td><td>27</td><td>25</td><td>24</td><td>21</td><td>20</td><td>19</td><td>18</td><td>17</td></tr> <tr><td colspan="2"></td><td>15</td><td>14</td><td>13</td><td>9</td><td>8</td><td>6</td><td>5</td><td>3</td><td>1</td><td></td></tr> </table>	72	70	68	67	66	65	58	57	55					49	47	44	43	42	41	39	37	35			73		32	30	27	25	24	21	20	19	18	17			15	14	13	9	8	6	5	3	1																
72	70	68	67	66	65	58	57	55																																																														
	49	47	44	43	42	41	39	37	35																																																													
73		32	30	27	25	24	21	20	19	18	17																																																											
		15	14	13	9	8	6	5	3	1																																																												
AVAILABLE	NOT APPLICABLE	34566-2353	G	0	A	BLACK	<table border="1"> <tr><td>72</td><td>70</td><td>67</td><td>66</td><td>65</td><td>58</td><td>57</td><td>55</td><td></td><td></td><td></td></tr> <tr><td></td><td>49</td><td>47</td><td>44</td><td>43</td><td>42</td><td>41</td><td>39</td><td>37</td><td>35</td><td></td><td></td></tr> <tr><td colspan="2">73</td><td>32</td><td>30</td><td>27</td><td>25</td><td>24</td><td>21</td><td>20</td><td>19</td><td>18</td><td>17</td></tr> <tr><td colspan="2"></td><td>15</td><td>14</td><td>13</td><td>9</td><td>8</td><td>6</td><td>5</td><td>3</td><td>1</td><td></td></tr> </table>	72	70	67	66	65	58	57	55					49	47	44	43	42	41	39	37	35			73		32	30	27	25	24	21	20	19	18	17			15	14	13	9	8	6	5	3	1																	
72	70	67	66	65	58	57	55																																																															
	49	47	44	43	42	41	39	37	35																																																													
73		32	30	27	25	24	21	20	19	18	17																																																											
		15	14	13	9	8	6	5	3	1																																																												
AVAILABLE	NOT APPLICABLE	34566-2363	G	0	C	BLUE	<table border="1"> <tr><td>72</td><td>70</td><td>67</td><td>66</td><td>63</td><td>62</td><td>59</td><td>57</td><td>53</td></tr> <tr><td>52</td><td>51</td><td>46</td><td>44</td><td>42</td><td>40</td><td>39</td><td>38</td><td>34</td><td>33</td></tr> <tr><td colspan="2">73</td><td>32</td><td>30</td><td>27</td><td>26</td><td>25</td><td>22</td><td>21</td><td>20</td><td></td></tr> <tr><td colspan="2"></td><td>15</td><td>14</td><td>10</td><td>9</td><td>6</td><td>5</td><td>4</td><td></td><td></td></tr> </table>	72	70	67	66	63	62	59	57	53	52	51	46	44	42	40	39	38	34	33	73		32	30	27	26	25	22	21	20				15	14	10	9	6	5	4																								
72	70	67	66	63	62	59	57	53																																																														
52	51	46	44	42	40	39	38	34	33																																																													
73		32	30	27	26	25	22	21	20																																																													
		15	14	10	9	6	5	4																																																														
AVAILABLE	NOT APPLICABLE	34566-2373	G	0	B	ST GRAY	<table border="1"> <tr><td>68</td><td>67</td><td>66</td><td>65</td><td>64</td><td>61</td><td>60</td><td>59</td><td>58</td><td>57</td><td>55</td><td>54</td><td>53</td></tr> <tr><td>51</td><td>50</td><td>49</td><td>48</td><td>47</td><td>46</td><td>45</td><td>43</td><td>42</td><td>41</td><td>40</td><td>39</td><td>38</td><td>37</td><td>35</td><td>34</td><td>33</td></tr> <tr><td colspan="2">73</td><td>32</td><td>31</td><td>30</td><td>26</td><td>24</td><td>23</td><td>22</td><td>21</td><td>20</td><td></td><td></td><td></td><td></td><td></td></tr> <tr><td colspan="2"></td><td>16</td><td>15</td><td>14</td><td>13</td><td>10</td><td>9</td><td>8</td><td>7</td><td>6</td><td>5</td><td>4</td><td>3</td><td>2</td><td></td><td></td></tr> </table>	68	67	66	65	64	61	60	59	58	57	55	54	53	51	50	49	48	47	46	45	43	42	41	40	39	38	37	35	34	33	73		32	31	30	26	24	23	22	21	20								16	15	14	13	10	9	8	7	6	5	4	3	2		
68	67	66	65	64	61	60	59	58	57	55	54	53																																																										
51	50	49	48	47	46	45	43	42	41	40	39	38	37	35	34	33																																																						
73		32	31	30	26	24	23	22	21	20																																																												
		16	15	14	13	10	9	8	7	6	5	4	3	2																																																								
AVAILABLE	NOT APPLICABLE	34566-2383	G	0	B	ST GRAY	<table border="1"> <tr><td>65</td><td>59</td><td>57</td><td>55</td><td>53</td></tr> <tr><td>50</td><td>49</td><td>48</td><td>46</td><td>39</td><td>37</td><td>35</td><td>33</td></tr> <tr><td colspan="2">73</td><td>29</td><td>24</td><td>23</td><td>21</td><td></td><td></td></tr> <tr><td colspan="2"></td><td>15</td><td>7</td><td>6</td><td>5</td><td>4</td><td>3</td><td></td><td></td><td></td></tr> </table>	65	59	57	55	53	50	49	48	46	39	37	35	33	73		29	24	23	21					15	7	6	5	4	3																																		
65	59	57	55	53																																																																		
50	49	48	46	39	37	35	33																																																															
73		29	24	23	21																																																																	
		15	7	6	5	4	3																																																															

ENTER DESCRIPTION IEC NO: UAU2014-0376 DRAWN BY: 2013/09/05 CHKD: 2013/09/06 APPR: VIOSHY REV: 05	QUALITY SYMBOLS	GENERAL TOLERANCES (UNLESS SPECIFIED)	DIMENSION STYLE	SCALE	DESIGN UNITS	THIRD ANGLE PROJECTION	
	$\nabla=0$ $\nabla=0$ $\nabla=0$	mm INCH 4 PLACES ± 3 PLACES ± 2 PLACES ± 1 PLACE ± 0 PLACE ±	MM ONLY	DRAWN BY: SKRAJENDRANA DATE: 2011/02/14 CHECKED BY: MVANSLAMBROU DATE: 2011/02/14 APPROVED BY:	METRIC		
	ANGULAR ±	DRAFT WHERE APPLICABLE MUST REMAIN WITHIN DIMENSIONS	SEE BOM TABLE	MATERIAL NO.	DOCUMENT NO.	TITLE: MX123 66/73/80CKT HRNS CONN ASSY molex SD-34566-001	
						SHEET NO. 28 OF 68	THIS DRAWING CONTAINS INFORMATION THAT IS PROPRIETARY TO MOLEX INCORPORATED AND SHOULD NOT BE USED WITHOUT WRITTEN PERMISSION

STATUS	GM PART #	MATERIAL #	PART/MATERIAL REVISION	WIRE DRESS OPTION	KEY OPTION	COLOR (TPA)	NUMBERS INDICATE CAVITIES OPEN FOR CIRCUITS																																																																																																													
AVAILABLE	NOT APPLICABLE	34566-2393	G	0	B	ST GRY	<table border="1"> <tr><td></td><td></td><td></td><td></td><td></td><td></td><td></td><td></td><td></td><td></td><td></td><td></td><td></td><td></td><td></td><td></td><td></td><td>59</td><td>57</td><td>55</td><td>53</td></tr> <tr><td></td><td>50</td><td>49</td><td>48</td><td>46</td><td></td><td></td><td></td><td></td><td></td><td></td><td></td><td></td><td></td><td></td><td></td><td></td><td>39</td><td>37</td><td>35</td><td>33</td></tr> <tr><td>73</td><td></td><td></td><td></td><td></td><td></td><td>29</td><td></td><td></td><td></td><td></td><td></td><td></td><td></td><td></td><td></td><td>23</td><td>21</td><td></td><td>17</td></tr> <tr><td></td><td></td><td></td><td></td><td></td><td></td><td></td><td>15</td><td></td><td>12</td><td></td><td></td><td></td><td></td><td></td><td></td><td>7</td><td>6</td><td>5</td><td>4</td><td>3</td><td></td></tr> </table>																		59	57	55	53		50	49	48	46													39	37	35	33	73						29										23	21		17								15		12							7	6	5	4	3																										
																	59	57	55	53																																																																																																
	50	49	48	46													39	37	35	33																																																																																																
73						29										23	21		17																																																																																																	
							15		12							7	6	5	4	3																																																																																																
AVAILABLE	NOT APPLICABLE	34566-2413	G	0	A	BLACK	<table border="1"> <tr><td></td><td></td><td>70</td><td></td><td></td><td>67</td><td>66</td><td>65</td><td></td><td></td><td></td><td></td><td></td><td></td><td></td><td></td><td></td><td>58</td><td>57</td><td>55</td><td></td><td></td></tr> <tr><td></td><td></td><td></td><td>49</td><td></td><td>47</td><td></td><td></td><td>44</td><td>43</td><td>42</td><td>41</td><td></td><td></td><td>39</td><td></td><td></td><td>37</td><td>35</td><td></td><td></td><td></td></tr> <tr><td>73</td><td></td><td></td><td></td><td>32</td><td>30</td><td></td><td></td><td></td><td></td><td>27</td><td></td><td>25</td><td>24</td><td></td><td></td><td>21</td><td>20</td><td>19</td><td>18</td><td>17</td><td></td></tr> <tr><td></td><td></td><td></td><td></td><td></td><td></td><td>15</td><td>14</td><td>13</td><td></td><td></td><td></td><td>9</td><td>8</td><td></td><td></td><td>6</td><td>5</td><td>4</td><td>3</td><td></td><td>1</td></tr> </table>			70			67	66	65										58	57	55						49		47			44	43	42	41			39			37	35				73				32	30					27		25	24			21	20	19	18	17								15	14	13				9	8			6	5	4	3		1																					
		70			67	66	65										58	57	55																																																																																																	
			49		47			44	43	42	41			39			37	35																																																																																																		
73				32	30					27		25	24			21	20	19	18	17																																																																																																
						15	14	13				9	8			6	5	4	3		1																																																																																															
AVAILABLE	NOT APPLICABLE	34566-2423	G	0	A	BLACK	<table border="1"> <tr><td></td><td></td><td></td><td></td><td></td><td></td><td></td><td></td><td></td><td></td><td></td><td></td><td></td><td></td><td></td><td></td><td></td><td>63</td><td></td><td></td><td>58</td><td>57</td><td>56</td><td>55</td><td>54</td><td>53</td></tr> <tr><td>52</td><td>51</td><td></td><td>49</td><td></td><td></td><td></td><td></td><td></td><td>44</td><td>43</td><td>42</td><td>41</td><td></td><td></td><td></td><td></td><td></td><td></td><td></td><td></td><td></td><td>36</td><td>35</td><td>34</td><td>33</td></tr> <tr><td>73</td><td></td><td></td><td></td><td>32</td><td></td><td></td><td></td><td></td><td>28</td><td></td><td>26</td><td></td><td></td><td></td><td></td><td></td><td></td><td></td><td></td><td></td><td></td><td></td><td>19</td><td>18</td><td></td></tr> <tr><td></td><td></td><td></td><td></td><td></td><td>16</td><td></td><td></td><td></td><td></td><td>12</td><td></td><td>10</td><td></td><td></td><td></td><td>7</td><td>6</td><td></td><td></td><td></td><td></td><td></td><td>3</td><td></td><td></td></tr> </table>																		63			58	57	56	55	54	53	52	51		49						44	43	42	41										36	35	34	33	73				32					28		26												19	18							16					12		10				7	6						3							
																	63			58	57	56	55	54	53																																																																																											
52	51		49						44	43	42	41										36	35	34	33																																																																																											
73				32					28		26												19	18																																																																																												
					16					12		10				7	6						3																																																																																													
AVAILABLE	NOT APPLICABLE	34566-2433	G	0	A	BLACK	<table border="1"> <tr><td></td><td></td><td></td><td>69</td><td></td><td></td><td></td><td></td><td></td><td></td><td></td><td></td><td></td><td></td><td></td><td></td><td></td><td></td><td></td><td></td><td></td><td></td><td>56</td><td>55</td><td>54</td><td>53</td></tr> <tr><td>52</td><td>51</td><td></td><td>49</td><td></td><td></td><td></td><td></td><td></td><td>44</td><td>43</td><td>42</td><td>41</td><td></td><td></td><td></td><td></td><td></td><td></td><td></td><td></td><td></td><td></td><td>36</td><td>35</td><td>34</td><td>33</td></tr> <tr><td>73</td><td></td><td></td><td></td><td>32</td><td></td><td></td><td></td><td></td><td>28</td><td></td><td>26</td><td></td><td></td><td></td><td>23</td><td></td><td></td><td></td><td></td><td></td><td></td><td></td><td>19</td><td>18</td><td></td></tr> <tr><td></td><td></td><td></td><td></td><td></td><td>16</td><td></td><td></td><td></td><td></td><td>12</td><td></td><td>10</td><td></td><td></td><td></td><td>7</td><td>6</td><td></td><td></td><td></td><td></td><td></td><td>3</td><td></td><td></td></tr> </table>				69																			56	55	54	53	52	51		49						44	43	42	41											36	35	34	33	73				32					28		26				23								19	18							16					12		10				7	6						3						
			69																			56	55	54	53																																																																																											
52	51		49						44	43	42	41											36	35	34	33																																																																																										
73				32					28		26				23								19	18																																																																																												
					16					12		10				7	6						3																																																																																													
AVAILABLE	NOT APPLICABLE	34566-2443	G	0	C	BLUE	<table border="1"> <tr><td>72</td><td></td><td>70</td><td></td><td></td><td>68</td><td>66</td><td></td><td></td><td></td><td></td><td></td><td></td><td></td><td></td><td></td><td></td><td>59</td><td>57</td><td></td><td></td><td></td><td></td><td></td><td>53</td></tr> <tr><td>52</td><td>51</td><td></td><td></td><td></td><td>48</td><td>47</td><td>46</td><td>44</td><td></td><td></td><td></td><td></td><td></td><td></td><td></td><td></td><td>40</td><td>39</td><td></td><td></td><td></td><td></td><td></td><td>34</td><td>33</td></tr> <tr><td>73</td><td></td><td></td><td></td><td>32</td><td>30</td><td></td><td></td><td></td><td></td><td></td><td>26</td><td>25</td><td></td><td></td><td></td><td></td><td></td><td></td><td>22</td><td>21</td><td>20</td><td></td><td></td><td></td><td></td></tr> <tr><td></td><td></td><td></td><td></td><td></td><td></td><td>15</td><td>14</td><td>13</td><td></td><td></td><td></td><td>10</td><td>9</td><td></td><td></td><td></td><td></td><td></td><td>6</td><td>5</td><td>4</td><td></td><td></td><td></td><td></td></tr> </table>	72		70			68	66											59	57						53	52	51				48	47	46	44									40	39						34	33	73				32	30						26	25							22	21	20											15	14	13				10	9						6	5	4										
72		70			68	66											59	57						53																																																																																												
52	51				48	47	46	44									40	39						34	33																																																																																											
73				32	30						26	25							22	21	20																																																																																															
						15	14	13				10	9						6	5	4																																																																																															
AVAILABLE	NOT APPLICABLE	34566-2453	G	0	A	BLACK	<table border="1"> <tr><td></td><td>71</td><td>69</td><td></td><td></td><td></td><td></td><td></td><td>65</td><td>64</td><td>63</td><td></td><td></td><td></td><td></td><td></td><td></td><td></td><td></td><td>58</td><td>57</td><td>56</td><td>55</td><td>54</td><td>53</td></tr> <tr><td>52</td><td>51</td><td></td><td>49</td><td></td><td></td><td></td><td></td><td>45</td><td>44</td><td>43</td><td>42</td><td>41</td><td></td><td></td><td></td><td></td><td></td><td></td><td></td><td></td><td></td><td>37</td><td>36</td><td>35</td><td>34</td><td>33</td></tr> <tr><td>73</td><td></td><td></td><td></td><td>32</td><td>30</td><td></td><td></td><td></td><td>28</td><td></td><td>26</td><td></td><td></td><td></td><td></td><td>23</td><td></td><td></td><td></td><td></td><td></td><td></td><td>19</td><td>18</td><td></td></tr> <tr><td></td><td></td><td></td><td></td><td></td><td>16</td><td></td><td></td><td></td><td></td><td>12</td><td></td><td>10</td><td></td><td></td><td></td><td>7</td><td>6</td><td></td><td></td><td></td><td></td><td></td><td>3</td><td></td><td></td></tr> </table>		71	69						65	64	63									58	57	56	55	54	53	52	51		49					45	44	43	42	41										37	36	35	34	33	73				32	30				28		26					23							19	18							16					12		10				7	6						3							
	71	69						65	64	63									58	57	56	55	54	53																																																																																												
52	51		49					45	44	43	42	41										37	36	35	34	33																																																																																										
73				32	30				28		26					23							19	18																																																																																												
					16					12		10				7	6						3																																																																																													
AVAILABLE	NOT APPLICABLE	34566-2463	G	0	A	BLACK	<table border="1"> <tr><td></td><td>71</td><td>69</td><td></td><td></td><td></td><td></td><td></td><td>65</td><td>64</td><td>63</td><td></td><td></td><td></td><td></td><td></td><td></td><td></td><td></td><td></td><td></td><td></td><td>57</td><td>56</td><td>55</td><td>54</td><td>53</td></tr> <tr><td>52</td><td>51</td><td></td><td>49</td><td></td><td></td><td></td><td></td><td>45</td><td>44</td><td>43</td><td>42</td><td>41</td><td></td><td></td><td></td><td></td><td></td><td></td><td></td><td></td><td></td><td></td><td>37</td><td>36</td><td>35</td><td>34</td><td>33</td></tr> <tr><td>73</td><td></td><td></td><td></td><td>32</td><td>30</td><td>29</td><td>28</td><td></td><td>26</td><td></td><td></td><td></td><td></td><td></td><td>23</td><td></td><td></td><td></td><td></td><td></td><td></td><td></td><td>19</td><td>18</td><td></td><td></td></tr> <tr><td></td><td></td><td></td><td></td><td></td><td>16</td><td></td><td></td><td></td><td></td><td>12</td><td></td><td>10</td><td></td><td></td><td></td><td>7</td><td>6</td><td></td><td></td><td></td><td></td><td></td><td>3</td><td></td><td></td><td></td></tr> </table>		71	69						65	64	63												57	56	55	54	53	52	51		49					45	44	43	42	41											37	36	35	34	33	73				32	30	29	28		26						23								19	18								16					12		10				7	6						3			
	71	69						65	64	63												57	56	55	54	53																																																																																										
52	51		49					45	44	43	42	41											37	36	35	34	33																																																																																									
73				32	30	29	28		26						23								19	18																																																																																												
					16					12		10				7	6						3																																																																																													
AVAILABLE	NOT APPLICABLE	34566-2473	G	0	A	BLACK	<table border="1"> <tr><td></td><td></td><td>70</td><td></td><td></td><td>68</td><td>67</td><td>66</td><td>65</td><td></td><td></td><td></td><td></td><td></td><td></td><td></td><td></td><td></td><td></td><td></td><td></td><td></td><td>58</td><td>57</td><td>55</td><td></td><td></td></tr> <tr><td></td><td></td><td></td><td>49</td><td></td><td>47</td><td></td><td></td><td>44</td><td>43</td><td>42</td><td>41</td><td></td><td></td><td>39</td><td></td><td></td><td></td><td></td><td></td><td></td><td></td><td></td><td>37</td><td>35</td><td></td><td></td></tr> <tr><td>73</td><td></td><td></td><td></td><td>32</td><td>30</td><td></td><td></td><td></td><td></td><td>27</td><td></td><td>25</td><td>24</td><td></td><td></td><td></td><td></td><td></td><td>21</td><td>20</td><td>19</td><td>18</td><td>17</td><td></td><td></td></tr> <tr><td></td><td></td><td></td><td></td><td></td><td></td><td>15</td><td>14</td><td>13</td><td></td><td></td><td></td><td></td><td>9</td><td>8</td><td></td><td></td><td></td><td></td><td>6</td><td>5</td><td>4</td><td>3</td><td></td><td></td><td>1</td></tr> </table>			70			68	67	66	65														58	57	55						49		47			44	43	42	41			39									37	35			73				32	30					27		25	24						21	20	19	18	17									15	14	13					9	8					6	5	4	3			1			
		70			68	67	66	65														58	57	55																																																																																												
			49		47			44	43	42	41			39									37	35																																																																																												
73				32	30					27		25	24						21	20	19	18	17																																																																																													
						15	14	13					9	8					6	5	4	3			1																																																																																											

ENTER DESCRIPTION ELEC NO: UAU2014-0376 DRAWN BY: 2013/09/05 CHKD: 2013/09/06 APPR: VIOSHY REV: 05	QUALITY SYMBOLS	GENERAL TOLERANCES (UNLESS SPECIFIED)	DIMENSION STYLE	SCALE	DESIGN UNITS	THIRD ANGLE PROJECTION
	∇=0 ∇=0 ∇=0	4 PLACES ±---+--- mm 3 PLACES ±---+--- INCH 2 PLACES ±---+--- 1 PLACE ±---+--- 0 PLACE ±---+---	MM ONLY	METRIC	DRAWN BY: SKRA JENDRANA 2011/02/14 CHECKED BY: MVANSLAMBROU 2011/02/14 APPROVED BY:	MX123 66/73/80CKT HRNS CONN ASSY molex
	ANGULAR ±---° DRAFT WHERE APPLICABLE MUST REMAIN WITHIN DIMENSIONS		SEE BOM TABLE THIS DRAWING CONTAINS INFORMATION THAT IS PROPRIETARY TO MOLEX INCORPORATED AND SHOULD NOT BE USED WITHOUT WRITTEN PERMISSION	MATERIAL NO. DOCUMENT NO. SD-34566-001 SHEET NO. 29 OF 68		

STATUS	GM PART #	MATERIAL #	PART/MATERIAL REVISION	WIRE DRESS OPTION	KEY OPTION	COLOR (TPA)	NUMBERS INDICATE CAVITIES OPEN FOR CIRCUITS																																																																																							
AVAILABLE	NOT APPLICABLE	34566-2483	G	0	A	BLACK	<table border="1"> <tr><td></td><td></td><td></td><td>69</td><td></td><td></td><td></td><td></td><td></td><td></td><td>63</td><td>62</td><td>61</td><td></td><td></td><td>58</td><td>57</td><td>56</td><td>55</td><td>54</td><td>53</td></tr> <tr><td>52</td><td>51</td><td>49</td><td></td><td></td><td></td><td></td><td></td><td></td><td>44</td><td>43</td><td>42</td><td>41</td><td></td><td></td><td></td><td>37</td><td>36</td><td>35</td><td>34</td><td>33</td></tr> <tr><td colspan="2">73</td><td></td><td></td><td></td><td></td><td></td><td></td><td></td><td></td><td></td><td></td><td></td><td></td><td></td><td></td><td></td><td></td><td></td><td>19</td><td>18</td></tr> <tr><td></td><td></td><td></td><td></td><td></td><td></td><td></td><td></td><td></td><td></td><td></td><td></td><td></td><td></td><td></td><td></td><td></td><td></td><td></td><td>3</td><td></td></tr> </table>				69							63	62	61			58	57	56	55	54	53	52	51	49							44	43	42	41				37	36	35	34	33	73																			19	18																				3				
			69							63	62	61			58	57	56	55	54	53																																																																										
52	51	49							44	43	42	41				37	36	35	34	33																																																																										
73																			19	18																																																																										
																			3																																																																											
AVAILABLE	NOT APPLICABLE	34566-2493	G	0	B	ST GRY	<table border="1"> <tr><td>72</td><td>71</td><td>70</td><td></td><td>68</td><td>67</td><td>66</td><td></td><td></td><td></td><td>62</td><td>61</td><td>60</td><td>59</td><td>58</td><td>57</td><td>56</td><td>55</td><td>54</td><td>53</td></tr> <tr><td>52</td><td>51</td><td>50</td><td></td><td>48</td><td>47</td><td>46</td><td></td><td></td><td></td><td>42</td><td>41</td><td>40</td><td>39</td><td>38</td><td>37</td><td>36</td><td>35</td><td>34</td><td>33</td></tr> <tr><td colspan="2">73</td><td></td><td></td><td>32</td><td>31</td><td>30</td><td>29</td><td>28</td><td>27</td><td>26</td><td>25</td><td>24</td><td></td><td></td><td></td><td></td><td></td><td></td><td>17</td></tr> <tr><td></td><td></td><td></td><td></td><td>16</td><td>15</td><td>14</td><td>13</td><td></td><td></td><td></td><td></td><td>10</td><td>8</td><td></td><td></td><td></td><td></td><td></td><td>2</td><td>1</td></tr> </table>	72	71	70		68	67	66				62	61	60	59	58	57	56	55	54	53	52	51	50		48	47	46				42	41	40	39	38	37	36	35	34	33	73				32	31	30	29	28	27	26	25	24							17					16	15	14	13					10	8						2	1						
72	71	70		68	67	66				62	61	60	59	58	57	56	55	54	53																																																																											
52	51	50		48	47	46				42	41	40	39	38	37	36	35	34	33																																																																											
73				32	31	30	29	28	27	26	25	24							17																																																																											
				16	15	14	13					10	8						2	1																																																																										
AVAILABLE	NOT APPLICABLE	34566-2513	G	0	C	BLUE	<table border="1"> <tr><td>72</td><td>71</td><td>70</td><td></td><td>68</td><td>67</td><td>66</td><td></td><td></td><td></td><td>62</td><td>61</td><td></td><td>59</td><td></td><td>57</td><td></td><td></td><td></td><td>53</td></tr> <tr><td>52</td><td>51</td><td></td><td></td><td>48</td><td>47</td><td>46</td><td></td><td></td><td></td><td>42</td><td>41</td><td>40</td><td>39</td><td></td><td></td><td></td><td></td><td></td><td>34</td><td>33</td></tr> <tr><td colspan="2">73</td><td></td><td></td><td>32</td><td></td><td>30</td><td></td><td></td><td></td><td>27</td><td>26</td><td>25</td><td></td><td></td><td>22</td><td>21</td><td>20</td><td></td><td></td><td></td></tr> <tr><td></td><td></td><td></td><td></td><td></td><td>15</td><td>14</td><td></td><td></td><td></td><td></td><td>10</td><td>9</td><td></td><td></td><td>6</td><td>5</td><td>4</td><td></td><td></td><td></td></tr> </table>	72	71	70		68	67	66				62	61		59		57				53	52	51			48	47	46				42	41	40	39						34	33	73				32		30				27	26	25			22	21	20									15	14					10	9			6	5	4							
72	71	70		68	67	66				62	61		59		57				53																																																																											
52	51			48	47	46				42	41	40	39						34	33																																																																										
73				32		30				27	26	25			22	21	20																																																																													
					15	14					10	9			6	5	4																																																																													
AVAILABLE	NOT APPLICABLE	34566-2523	G	0	A	BLACK	<table border="1"> <tr><td>72</td><td>71</td><td>70</td><td>69</td><td>68</td><td>67</td><td>66</td><td></td><td>65</td><td>64</td><td>63</td><td>62</td><td></td><td>60</td><td>59</td><td></td><td></td><td></td><td>55</td><td>54</td><td>53</td></tr> <tr><td>52</td><td></td><td></td><td>49</td><td>48</td><td></td><td></td><td></td><td>45</td><td>44</td><td>43</td><td>42</td><td></td><td>41</td><td>40</td><td>39</td><td></td><td></td><td></td><td>35</td><td>34</td><td>33</td></tr> <tr><td colspan="2">73</td><td></td><td></td><td>32</td><td></td><td></td><td></td><td>29</td><td>28</td><td>27</td><td>26</td><td>25</td><td>24</td><td>23</td><td></td><td></td><td></td><td></td><td>19</td><td>18</td><td>17</td></tr> <tr><td></td><td></td><td></td><td></td><td>16</td><td></td><td></td><td></td><td>13</td><td>12</td><td>11</td><td></td><td></td><td>9</td><td>8</td><td>7</td><td>6</td><td>5</td><td>4</td><td>3</td><td>2</td><td>1</td></tr> </table>	72	71	70	69	68	67	66		65	64	63	62		60	59				55	54	53	52			49	48				45	44	43	42		41	40	39				35	34	33	73				32				29	28	27	26	25	24	23					19	18	17					16				13	12	11			9	8	7	6	5	4	3	2	1
72	71	70	69	68	67	66		65	64	63	62		60	59				55	54	53																																																																										
52			49	48				45	44	43	42		41	40	39				35	34	33																																																																									
73				32				29	28	27	26	25	24	23					19	18	17																																																																									
				16				13	12	11			9	8	7	6	5	4	3	2	1																																																																									
AVAILABLE	NOT APPLICABLE	34566-2533	G	0	B	ST GRY	<table border="1"> <tr><td></td><td></td><td></td><td></td><td>67</td><td>66</td><td>65</td><td></td><td></td><td></td><td>63</td><td></td><td></td><td></td><td>59</td><td>58</td><td>57</td><td>56</td><td>55</td><td></td><td>53</td></tr> <tr><td></td><td></td><td>50</td><td>49</td><td>48</td><td></td><td>46</td><td>45</td><td>43</td><td></td><td></td><td></td><td></td><td></td><td>39</td><td>38</td><td>37</td><td>36</td><td>35</td><td>34</td><td>33</td></tr> <tr><td colspan="2">73</td><td></td><td></td><td></td><td></td><td></td><td></td><td>29</td><td>27</td><td></td><td></td><td></td><td></td><td>23</td><td>22</td><td>21</td><td></td><td></td><td></td><td>18</td></tr> <tr><td></td><td></td><td></td><td></td><td></td><td></td><td></td><td></td><td></td><td></td><td></td><td></td><td></td><td></td><td>8</td><td>7</td><td>6</td><td>5</td><td>4</td><td>3</td><td></td></tr> </table>					67	66	65				63				59	58	57	56	55		53			50	49	48		46	45	43						39	38	37	36	35	34	33	73								29	27					23	22	21				18															8	7	6	5	4	3				
				67	66	65				63				59	58	57	56	55		53																																																																										
		50	49	48		46	45	43						39	38	37	36	35	34	33																																																																										
73								29	27					23	22	21				18																																																																										
														8	7	6	5	4	3																																																																											
AVAILABLE	NOT APPLICABLE	34566-2543	G	0	C	BLUE	<table border="1"> <tr><td>72</td><td>71</td><td>70</td><td></td><td></td><td></td><td>66</td><td></td><td></td><td></td><td>63</td><td></td><td></td><td>59</td><td></td><td>57</td><td></td><td></td><td></td><td></td><td>53</td></tr> <tr><td>52</td><td>51</td><td></td><td></td><td></td><td></td><td>46</td><td></td><td></td><td>44</td><td></td><td>42</td><td></td><td>40</td><td>39</td><td></td><td></td><td></td><td></td><td></td><td>34</td><td>33</td></tr> <tr><td colspan="2">73</td><td></td><td></td><td>32</td><td></td><td>30</td><td></td><td></td><td></td><td>27</td><td>26</td><td>25</td><td></td><td></td><td>22</td><td>21</td><td></td><td></td><td></td><td></td><td></td></tr> <tr><td></td><td></td><td></td><td></td><td></td><td>15</td><td>14</td><td></td><td></td><td></td><td></td><td>10</td><td>9</td><td></td><td></td><td>6</td><td></td><td></td><td></td><td></td><td></td><td></td></tr> </table>	72	71	70				66				63			59		57					53	52	51					46			44		42		40	39						34	33	73				32		30				27	26	25			22	21											15	14					10	9			6						
72	71	70				66				63			59		57					53																																																																										
52	51					46			44		42		40	39						34	33																																																																									
73				32		30				27	26	25			22	21																																																																														
					15	14					10	9			6																																																																															
AVAILABLE	NOT APPLICABLE	34566-2553	G	9	B	ST GRY	<table border="1"> <tr><td>72</td><td>71</td><td>70</td><td></td><td>68</td><td>67</td><td>66</td><td></td><td></td><td></td><td>62</td><td>61</td><td>60</td><td>59</td><td>58</td><td>57</td><td>56</td><td>55</td><td>54</td><td>53</td></tr> <tr><td>52</td><td>51</td><td>50</td><td></td><td>48</td><td>47</td><td>46</td><td></td><td></td><td></td><td>42</td><td>41</td><td>40</td><td>39</td><td>38</td><td>37</td><td>36</td><td>35</td><td>34</td><td>33</td></tr> <tr><td colspan="2">73</td><td></td><td></td><td>32</td><td>31</td><td>30</td><td>29</td><td>28</td><td>27</td><td>26</td><td>25</td><td>24</td><td>23</td><td></td><td></td><td></td><td></td><td></td><td></td><td></td></tr> <tr><td></td><td></td><td></td><td></td><td>16</td><td>15</td><td>14</td><td>13</td><td></td><td></td><td></td><td>10</td><td>9</td><td>8</td><td></td><td></td><td></td><td></td><td></td><td></td><td></td></tr> </table>	72	71	70		68	67	66				62	61	60	59	58	57	56	55	54	53	52	51	50		48	47	46				42	41	40	39	38	37	36	35	34	33	73				32	31	30	29	28	27	26	25	24	23												16	15	14	13				10	9	8												
72	71	70		68	67	66				62	61	60	59	58	57	56	55	54	53																																																																											
52	51	50		48	47	46				42	41	40	39	38	37	36	35	34	33																																																																											
73				32	31	30	29	28	27	26	25	24	23																																																																																	
				16	15	14	13				10	9	8																																																																																	
AVAILABLE	NOT APPLICABLE	34566-2563	G	9	A	BLACK	<table border="1"> <tr><td></td><td></td><td></td><td>69</td><td></td><td></td><td></td><td></td><td></td><td></td><td>63</td><td>62</td><td>61</td><td></td><td></td><td>58</td><td>57</td><td>56</td><td>55</td><td>54</td><td>53</td></tr> <tr><td>52</td><td>51</td><td>50</td><td>49</td><td></td><td></td><td></td><td></td><td></td><td></td><td>44</td><td>43</td><td>42</td><td>41</td><td></td><td></td><td>37</td><td>36</td><td>35</td><td>34</td><td>33</td></tr> <tr><td colspan="2">73</td><td></td><td></td><td>32</td><td></td><td></td><td></td><td></td><td></td><td>29</td><td>28</td><td>27</td><td>26</td><td></td><td></td><td></td><td></td><td></td><td>19</td><td>18</td></tr> <tr><td></td><td></td><td></td><td></td><td>16</td><td></td><td>14</td><td>13</td><td>12</td><td>11</td><td>10</td><td></td><td></td><td></td><td></td><td></td><td></td><td></td><td></td><td>3</td><td></td></tr> </table>				69							63	62	61			58	57	56	55	54	53	52	51	50	49							44	43	42	41			37	36	35	34	33	73				32						29	28	27	26						19	18					16		14	13	12	11	10									3				
			69							63	62	61			58	57	56	55	54	53																																																																										
52	51	50	49							44	43	42	41			37	36	35	34	33																																																																										
73				32						29	28	27	26						19	18																																																																										
				16		14	13	12	11	10									3																																																																											
AVAILABLE	NOT APPLICABLE	34566-2573	G	9	C	BLUE	<table border="1"> <tr><td>72</td><td>71</td><td>70</td><td></td><td>67</td><td>66</td><td></td><td></td><td></td><td></td><td>63</td><td>62</td><td></td><td>59</td><td></td><td>57</td><td></td><td></td><td></td><td></td><td>53</td></tr> <tr><td>52</td><td>51</td><td></td><td></td><td>46</td><td></td><td>44</td><td></td><td></td><td></td><td>42</td><td>41</td><td>40</td><td>39</td><td></td><td></td><td></td><td></td><td></td><td></td><td>34</td><td>33</td></tr> <tr><td colspan="2">73</td><td></td><td></td><td></td><td></td><td>30</td><td></td><td></td><td></td><td></td><td>26</td><td>25</td><td></td><td></td><td>22</td><td>21</td><td>20</td><td></td><td></td><td></td><td></td></tr> <tr><td></td><td></td><td></td><td></td><td></td><td>15</td><td>14</td><td></td><td></td><td></td><td></td><td></td><td>10</td><td>9</td><td></td><td></td><td>6</td><td>5</td><td>4</td><td></td><td></td><td></td></tr> </table>	72	71	70		67	66					63	62		59		57					53	52	51			46		44				42	41	40	39							34	33	73						30					26	25			22	21	20										15	14						10	9			6	5	4			
72	71	70		67	66					63	62		59		57					53																																																																										
52	51			46		44				42	41	40	39							34	33																																																																									
73						30					26	25			22	21	20																																																																													
					15	14						10	9			6	5	4																																																																												

ENTER DESCRIPTION ELEC NO: UAU2014-0376 DRAWN BY: 2013/09/05 CHKD: APPR: IKOSHY REV: 05	QUALITY SYMBOLS ∇=0 ∇=0 ∇=0	GENERAL TOLERANCES (UNLESS SPECIFIED) mm INCH 4 PLACES ±---+--- 3 PLACES ±---+--- 2 PLACES ±---+--- 1 PLACE ±---+--- 0 PLACE ±---+--- ANGULAR ±---° DRAFT WHERE APPLICABLE MUST REMAIN WITHIN DIMENSIONS	DIMENSION STYLE MM ONLY DRAWN BY: SKRA JENDRANA 2011/02/14 CHECKED BY: MYANSLAMBROU 2011/02/14 APPROVED BY:	SCALE DESIGN UNITS METRIC THIRD ANGLE PROJECTION	TITLE MX123 66/73/80CKT HRNS CONN ASSY molex	MATERIAL NO. DOCUMENT NO. SD-34566-001	SHEET NO. 30 OF 68
	SEE BOM TABLE			THIS DRAWING CONTAINS INFORMATION THAT IS PROPRIETARY TO MOLEX INCORPORATED AND SHOULD NOT BE USED WITHOUT WRITTEN PERMISSION			

STATUS	GM PART #	MATERIAL #	PART/MATERIAL REVISION	WIRE DRESS OPTION	KEY OPTION	COLOR (TPA)	NUMBERS INDICATE CAVITIES OPEN FOR CIRCUITS																																																																										
AVAILABLE	NOT APPLICABLE	34566-2583	G	0	A	BLACK	<table border="1"> <tr><td></td><td></td><td>69</td><td></td><td></td><td></td><td>63</td><td></td><td></td><td>58</td><td>56</td><td>55</td><td>54</td><td>53</td></tr> <tr><td>52</td><td>51</td><td>50</td><td>49</td><td></td><td></td><td>44</td><td>43</td><td>42</td><td>41</td><td>39</td><td></td><td>36</td><td>35</td><td>34</td><td>33</td></tr> <tr><td></td><td></td><td></td><td>32</td><td></td><td></td><td>28</td><td>26</td><td></td><td></td><td></td><td></td><td></td><td>19</td><td>18</td><td></td></tr> <tr><td></td><td></td><td>73</td><td>16</td><td>14</td><td>12</td><td>10</td><td></td><td></td><td></td><td></td><td></td><td>3</td><td></td><td></td><td></td></tr> </table>			69				63			58	56	55	54	53	52	51	50	49			44	43	42	41	39		36	35	34	33				32			28	26						19	18				73	16	14	12	10						3															
		69				63			58	56	55	54	53																																																																				
52	51	50	49			44	43	42	41	39		36	35	34	33																																																																		
			32			28	26						19	18																																																																			
		73	16	14	12	10						3																																																																					
AVAILABLE	NOT APPLICABLE	34566-2593	G	0	C	BLUE	<table border="1"> <tr><td>72</td><td>70</td><td></td><td></td><td>66</td><td></td><td>63</td><td>62</td><td></td><td>59</td><td>57</td><td></td><td></td><td></td><td>53</td><td></td></tr> <tr><td>52</td><td>51</td><td></td><td></td><td>46</td><td>44</td><td>42</td><td>40</td><td>39</td><td></td><td></td><td></td><td></td><td></td><td>34</td><td>33</td></tr> <tr><td></td><td></td><td></td><td>32</td><td>30</td><td></td><td>27</td><td>26</td><td>25</td><td></td><td>22</td><td>21</td><td></td><td></td><td></td><td></td></tr> <tr><td></td><td></td><td>73</td><td>15</td><td>14</td><td></td><td>10</td><td>9</td><td></td><td>6</td><td></td><td></td><td></td><td></td><td></td><td></td></tr> </table>	72	70			66		63	62		59	57				53		52	51			46	44	42	40	39						34	33				32	30		27	26	25		22	21							73	15	14		10	9		6																
72	70			66		63	62		59	57				53																																																																			
52	51			46	44	42	40	39						34	33																																																																		
			32	30		27	26	25		22	21																																																																						
		73	15	14		10	9		6																																																																								
AVAILABLE	NOT APPLICABLE	34566-2613	G	9	C	BLUE	<table border="1"> <tr><td>72</td><td>70</td><td></td><td>67</td><td>66</td><td></td><td>63</td><td>62</td><td></td><td>59</td><td>57</td><td></td><td></td><td></td><td>53</td><td></td></tr> <tr><td>52</td><td>51</td><td></td><td></td><td>46</td><td>44</td><td>42</td><td>40</td><td>39</td><td></td><td></td><td></td><td></td><td></td><td>34</td><td>33</td></tr> <tr><td></td><td></td><td></td><td></td><td>30</td><td></td><td>27</td><td>26</td><td>25</td><td></td><td>22</td><td>21</td><td>20</td><td></td><td></td><td></td></tr> <tr><td></td><td></td><td>73</td><td></td><td>15</td><td>14</td><td></td><td>10</td><td>9</td><td></td><td>6</td><td>5</td><td>4</td><td></td><td></td><td></td></tr> </table>	72	70		67	66		63	62		59	57				53		52	51			46	44	42	40	39						34	33					30		27	26	25		22	21	20						73		15	14		10	9		6	5	4													
72	70		67	66		63	62		59	57				53																																																																			
52	51			46	44	42	40	39						34	33																																																																		
				30		27	26	25		22	21	20																																																																					
		73		15	14		10	9		6	5	4																																																																					
AVAILABLE	NOT APPLICABLE	34566-2623	G	0	A	BLACK	<table border="1"> <tr><td>71</td><td>69</td><td>68</td><td>67</td><td></td><td>65</td><td>64</td><td>63</td><td></td><td>61</td><td>59</td><td></td><td>57</td><td>56</td><td></td><td></td></tr> <tr><td></td><td>50</td><td>49</td><td>47</td><td></td><td></td><td></td><td></td><td></td><td>41</td><td></td><td></td><td>38</td><td>37</td><td>36</td><td>34</td><td>33</td></tr> <tr><td></td><td></td><td></td><td></td><td>32</td><td>31</td><td>30</td><td>29</td><td>28</td><td>27</td><td></td><td>24</td><td>23</td><td></td><td>20</td><td>19</td><td>18</td></tr> <tr><td></td><td></td><td>73</td><td></td><td>16</td><td></td><td></td><td>13</td><td>12</td><td>11</td><td>10</td><td>9</td><td>7</td><td></td><td>4</td><td></td><td></td></tr> </table>	71	69	68	67		65	64	63		61	59		57	56				50	49	47						41			38	37	36	34	33					32	31	30	29	28	27		24	23		20	19	18			73		16			13	12	11	10	9	7		4									
71	69	68	67		65	64	63		61	59		57	56																																																																				
	50	49	47						41			38	37	36	34	33																																																																	
				32	31	30	29	28	27		24	23		20	19	18																																																																	
		73		16			13	12	11	10	9	7		4																																																																			
AVAILABLE	NOT APPLICABLE	34566-2633	G	0	A	BLACK	<table border="1"> <tr><td>71</td><td>69</td><td>68</td><td>67</td><td></td><td>65</td><td>64</td><td></td><td></td><td>61</td><td>59</td><td></td><td>57</td><td>56</td><td></td><td></td></tr> <tr><td></td><td>50</td><td>49</td><td>47</td><td></td><td></td><td></td><td></td><td></td><td>41</td><td></td><td></td><td>38</td><td>37</td><td>36</td><td></td><td>33</td></tr> <tr><td></td><td></td><td></td><td></td><td>32</td><td>31</td><td>30</td><td>29</td><td>28</td><td>27</td><td></td><td>24</td><td>23</td><td></td><td>20</td><td>19</td><td>18</td></tr> <tr><td></td><td></td><td>73</td><td></td><td>16</td><td></td><td></td><td></td><td>11</td><td>10</td><td>9</td><td></td><td>7</td><td></td><td>4</td><td></td><td></td></tr> </table>	71	69	68	67		65	64			61	59		57	56				50	49	47						41			38	37	36		33					32	31	30	29	28	27		24	23		20	19	18			73		16				11	10	9		7		4									
71	69	68	67		65	64			61	59		57	56																																																																				
	50	49	47						41			38	37	36		33																																																																	
				32	31	30	29	28	27		24	23		20	19	18																																																																	
		73		16				11	10	9		7		4																																																																			
AVAILABLE	NOT APPLICABLE	34566-2643	G	0	A	BLACK	<table border="1"> <tr><td>71</td><td>69</td><td>68</td><td>67</td><td></td><td>65</td><td>64</td><td>63</td><td></td><td>61</td><td>59</td><td></td><td>57</td><td>56</td><td></td><td></td></tr> <tr><td></td><td>50</td><td>49</td><td>47</td><td></td><td></td><td></td><td></td><td></td><td>41</td><td>39</td><td>38</td><td>37</td><td>36</td><td></td><td>34</td><td>33</td></tr> <tr><td></td><td></td><td></td><td></td><td>32</td><td>31</td><td>30</td><td>29</td><td>28</td><td>27</td><td></td><td>24</td><td>23</td><td>22</td><td>20</td><td>19</td><td>18</td></tr> <tr><td></td><td></td><td>73</td><td></td><td>16</td><td></td><td></td><td>13</td><td>12</td><td>11</td><td>10</td><td>9</td><td>7</td><td></td><td>4</td><td></td><td></td></tr> </table>	71	69	68	67		65	64	63		61	59		57	56				50	49	47						41	39	38	37	36		34	33					32	31	30	29	28	27		24	23	22	20	19	18			73		16			13	12	11	10	9	7		4									
71	69	68	67		65	64	63		61	59		57	56																																																																				
	50	49	47						41	39	38	37	36		34	33																																																																	
				32	31	30	29	28	27		24	23	22	20	19	18																																																																	
		73		16			13	12	11	10	9	7		4																																																																			
AVAILABLE	NOT APPLICABLE	34566-2653	G	0	A	BLACK	<table border="1"> <tr><td>71</td><td>69</td><td>68</td><td>67</td><td></td><td>65</td><td>64</td><td></td><td></td><td>61</td><td>59</td><td></td><td>57</td><td>56</td><td></td><td></td></tr> <tr><td></td><td>50</td><td>49</td><td>47</td><td></td><td></td><td></td><td></td><td></td><td>41</td><td>39</td><td>38</td><td>37</td><td>36</td><td></td><td>34</td><td>33</td></tr> <tr><td></td><td></td><td></td><td></td><td>32</td><td>31</td><td>30</td><td>29</td><td>28</td><td>27</td><td></td><td>24</td><td>23</td><td>22</td><td>20</td><td>19</td><td>18</td></tr> <tr><td></td><td></td><td>73</td><td></td><td>16</td><td></td><td></td><td></td><td>11</td><td>10</td><td>9</td><td></td><td>7</td><td></td><td>4</td><td></td><td></td></tr> </table>	71	69	68	67		65	64			61	59		57	56				50	49	47						41	39	38	37	36		34	33					32	31	30	29	28	27		24	23	22	20	19	18			73		16				11	10	9		7		4									
71	69	68	67		65	64			61	59		57	56																																																																				
	50	49	47						41	39	38	37	36		34	33																																																																	
				32	31	30	29	28	27		24	23	22	20	19	18																																																																	
		73		16				11	10	9		7		4																																																																			
AVAILABLE	NOT APPLICABLE	34566-2663	G	0	H	ST GRAY	<table border="1"> <tr><td>79</td><td>78</td><td>77</td><td>76</td><td>75</td><td>74</td><td>73</td><td>72</td><td>71</td><td>70</td><td>69</td><td>68</td><td></td><td>66</td><td>65</td><td>64</td><td>63</td><td>61</td></tr> <tr><td>60</td><td>59</td><td>58</td><td>57</td><td>56</td><td></td><td></td><td>53</td><td>52</td><td>50</td><td></td><td></td><td></td><td></td><td></td><td>44</td><td>43</td><td>41</td></tr> <tr><td>40</td><td>39</td><td>38</td><td>37</td><td></td><td>35</td><td>34</td><td></td><td>32</td><td>30</td><td>29</td><td></td><td>27</td><td>26</td><td></td><td></td><td></td><td>22</td><td>21</td></tr> <tr><td>20</td><td>19</td><td>18</td><td>17</td><td></td><td></td><td></td><td>13</td><td>12</td><td></td><td></td><td></td><td>8</td><td>6</td><td>5</td><td></td><td>3</td><td>2</td><td></td></tr> </table>	79	78	77	76	75	74	73	72	71	70	69	68		66	65	64	63	61	60	59	58	57	56			53	52	50						44	43	41	40	39	38	37		35	34		32	30	29		27	26				22	21	20	19	18	17				13	12				8	6	5		3	2	
79	78	77	76	75	74	73	72	71	70	69	68		66	65	64	63	61																																																																
60	59	58	57	56			53	52	50						44	43	41																																																																
40	39	38	37		35	34		32	30	29		27	26				22	21																																																															
20	19	18	17				13	12				8	6	5		3	2																																																																
AVAILABLE	NOT APPLICABLE	34566-2673	G	0	H	ST GRAY	<table border="1"> <tr><td>79</td><td>78</td><td>77</td><td>76</td><td>75</td><td>74</td><td>73</td><td>72</td><td>71</td><td>70</td><td>69</td><td>68</td><td></td><td>66</td><td>65</td><td>64</td><td>63</td><td>61</td></tr> <tr><td>60</td><td>59</td><td>58</td><td>57</td><td>56</td><td></td><td></td><td>53</td><td>52</td><td>50</td><td></td><td></td><td></td><td></td><td></td><td>44</td><td>43</td><td>41</td></tr> <tr><td>40</td><td>39</td><td>38</td><td>37</td><td></td><td>35</td><td>34</td><td></td><td>32</td><td>30</td><td>29</td><td></td><td>27</td><td>26</td><td></td><td></td><td></td><td>22</td><td>21</td></tr> <tr><td>20</td><td>19</td><td>18</td><td>17</td><td>16</td><td></td><td></td><td>13</td><td>12</td><td></td><td></td><td></td><td>8</td><td>6</td><td>5</td><td></td><td>3</td><td>2</td><td></td></tr> </table>	79	78	77	76	75	74	73	72	71	70	69	68		66	65	64	63	61	60	59	58	57	56			53	52	50						44	43	41	40	39	38	37		35	34		32	30	29		27	26				22	21	20	19	18	17	16			13	12				8	6	5		3	2	
79	78	77	76	75	74	73	72	71	70	69	68		66	65	64	63	61																																																																
60	59	58	57	56			53	52	50						44	43	41																																																																
40	39	38	37		35	34		32	30	29		27	26				22	21																																																															
20	19	18	17	16			13	12				8	6	5		3	2																																																																

ENTER DESCRIPTION ELEC NO: UAU2014-0376 DRAWN BY: 2013/09/05 CHKD: 2013/09/06 APPR: IKOSHY REV: 05	QUALITY SYMBOLS ▽=0 ▽=0 ▽=0	GENERAL TOLERANCES (UNLESS SPECIFIED) mm INCH 4 PLACES ±--- ±--- 3 PLACES ±--- ±--- 2 PLACES ±--- ±--- 1 PLACE ±--- ±--- 0 PLACE ±--- ±--- ANGULAR ±---° DRAFT WHERE APPLICABLE MUST REMAIN WITHIN DIMENSIONS	DIMENSION STYLE MM ONLY DRAWN BY: SKRAJENDRANA 2011/02/14 CHECKED BY: DATE MYANSLAMBROU 2011/02/14 APPROVED BY: DATE	SCALE DESIGN UNITS METRIC THIRD ANGLE PROJECTION	TITLE MX123 66/73/80CKT HRNS CONN ASSY molex	MATERIAL NO. SD-34566-001	DOCUMENT NO. SHEET NO. 31 OF 68
	THIS DRAWING CONTAINS INFORMATION THAT IS PROPRIETARY TO MOLEX INCORPORATED AND SHOULD NOT BE USED WITHOUT WRITTEN PERMISSION						
	SEE BOM TABLE						
	SIZE D						

STATUS	GM PART #	MATERIAL #	PART/MATERIAL REVISION	WIRE DRESS OPTION	KEY OPTION ▽	COLOR (TPA) ▽	NUMBERS INDICATE CAVITIES OPEN FOR CIRCUITS ▽																		
							78	77	76	75	74	73	72	71	70	69	68	67	66	65	64	63	61		
AVAILABLE	NOT APPLICABLE	34566-2683	G	0	H	ST GR	60	59	58	57	56	55	54	53	52	51	50	48	47	46	45	44	43	41	
							40		37	35	34	32	30	29	27	26							22	21	
							20	19	18	17	16			13	12			8	7	6	5	4	3	2	1
AVAILABLE	NOT APPLICABLE	34566-2693	G	0	B	ST GR	71	70	68	66	65						60	59	58	57			54	53	
							51	50	49	48	46	45	43	42	41	40	39	38	37	36	35		33		
							73			32	31	30				24	23	22		20					
										16	15	13	12	11	10	9	8	7	6	5	4				
AVAILABLE	NOT APPLICABLE	34566-2713	G	0	A	BLACK	69	68				65	64	63		61	60	59	58		56				
							52	50	49		47					41	40	39	38	37	36		34	33	
							73			32	31	30	29	28	27	25	24	23			20	19	18	17	
										16			13	12	11	10	9							1	
AVAILABLE	NOT APPLICABLE	34566-2723	G	0	B	ST GR	71	70	68	66	65	64	63			60	59	58	57	56	55	54	53		
							51	50	49	48	46	45	43	42	41	40	39	38	37	36	35		33		
							73			32	31	30				24	23	22		20	19				
										16	15	13	12	11	10	9	8	7	6	5	4	3	2	1	
AVAILABLE	NOT APPLICABLE	34566-2733	G	0	A	BLACK			70	68	67	66	65						58	57		55			
									49		47			44	43	42	41	39		37					
							73			32		30			27	25	24	23		21	20	19	18	17	
										16	15		13			10	9	8		6	5	4		1	
AVAILABLE	NOT APPLICABLE	34566-2743	G	0	C	BLUE	72	70			67	66		63	62	61		59		57			53		
							52	51			46	44	42		40	39						34	33		
							73			32		30			26	25			22	21	20				
										15	14				10	9			6	5	4				
AVAILABLE	NOT APPLICABLE	34566-2753	G	0	A	BLACK								63	62	61			58	57	56	55	54	53	
							52	51	49					44	43	42	41			37	36	35	34	33	
							73			32			29	28	27	26						19	18		
										16	15	13	12	11	10						3				
AVAILABLE	NOT APPLICABLE	34566-2763	G	0	B	ST GR	72	71	70	68	67	66			62	61	60	59	58	57	56	55	54	53	
							52	51	50	48	47	46			42	41	40	39	38	37	36	35	34	33	
							73			32	31	30	29	28	27	26	25	24							
										16	15	14	13			10	9	8							
AVAILABLE	NOT APPLICABLE	34566-2773	G	0	H	ST GR								53										61	
															32										
							20										9				5			1	
AVAILABLE	NOT APPLICABLE	34566-2783	G	9	H	ST GR								53										61	
															32										
							20										9				5			1	

ENTER DESCRIPTION IEC NO: UAU2014-0376 DRAWN BY CHKD: APPR: VIOSHY 2013/09/06 REV: 05	QUALITY SYMBOLS	GENERAL TOLERANCES (UNLESS SPECIFIED)	DIMENSION STYLE	SCALE	DESIGN UNITS	THIRD ANGLE PROJECTION
	▽=0	4 PLACES ±	mm	MM ONLY	METRIC	
	▽=0	3 PLACES ±	INCH			
	▽=0	2 PLACES ±				
		ANGULAR ±				
		DRAFT WHERE APPLICABLE MUST REMAIN WITHIN DIMENSIONS	SEE BOM TABLE			
			DRAWN BY: SKRAJENDRANA	DATE: 2011/02/14	TITLE: MX123 66/73/80CKT HRNS CONN ASSY	
			CHECKED BY: MVANSLAMBROU	DATE: 2011/02/14		
			APPROVED BY:	DATE:		
			MATERIAL NO.	DOCUMENT NO.		
				SD-34566-001		
					SHEET NO. 32 OF 68	
					THIS DRAWING CONTAINS INFORMATION THAT IS PROPRIETARY TO MOLEX INCORPORATED AND SHOULD NOT BE USED WITHOUT WRITTEN PERMISSION	

STATUS	GM PART #	MATERIAL #	PART/MATERIAL REVISION	WIRE DRESS OPTION	KEY OPTION	COLOR (TPA)	NUMBERS INDICATE CAVITIES OPEN FOR CIRCUITS																																																																																
AVAILABLE	NOT APPLICABLE	34566-2793	G	9	A	BLACK	<table border="1"> <tr><td></td><td></td><td></td><td></td><td>67</td><td>66</td><td></td><td></td><td></td><td></td><td></td><td></td><td></td><td></td><td></td><td></td><td></td><td></td><td></td><td></td></tr> <tr><td></td><td></td><td></td><td></td><td>48</td><td>47</td><td></td><td></td><td></td><td></td><td></td><td></td><td></td><td>41</td><td></td><td></td><td></td><td></td><td></td><td></td></tr> <tr><td></td><td></td><td>73</td><td></td><td>32</td><td>31</td><td>30</td><td>29</td><td></td><td>27</td><td></td><td>25</td><td></td><td></td><td>22</td><td>21</td><td></td><td>19</td><td>18</td><td>17</td></tr> <tr><td></td><td></td><td></td><td></td><td>16</td><td>15</td><td>14</td><td>13</td><td></td><td>11</td><td>10</td><td>9</td><td>8</td><td>7</td><td>6</td><td>5</td><td>4</td><td>3</td><td>2</td><td>1</td></tr> </table>					67	66																			48	47								41									73		32	31	30	29		27		25			22	21		19	18	17					16	15	14	13		11	10	9	8	7	6	5	4	3	2	1
				67	66																																																																																		
				48	47								41																																																																										
		73		32	31	30	29		27		25			22	21		19	18	17																																																																				
				16	15	14	13		11	10	9	8	7	6	5	4	3	2	1																																																																				
AVAILABLE	NOT APPLICABLE	34566-2813	G	9	B	ST GRAY	<table border="1"> <tr><td>72</td><td>71</td><td>70</td><td>69</td><td>68</td><td>67</td><td>66</td><td>65</td><td>64</td><td></td><td>62</td><td>61</td><td>60</td><td>59</td><td>58</td><td>57</td><td>56</td><td>55</td><td>54</td><td></td></tr> <tr><td>52</td><td>51</td><td>50</td><td>49</td><td>48</td><td>46</td><td>44</td><td></td><td></td><td></td><td></td><td></td><td>40</td><td></td><td></td><td>37</td><td>36</td><td></td><td></td><td></td></tr> <tr><td></td><td></td><td></td><td></td><td>32</td><td>31</td><td>30</td><td>29</td><td>28</td><td>27</td><td></td><td>25</td><td>24</td><td></td><td></td><td>21</td><td>20</td><td></td><td>18</td><td></td></tr> <tr><td></td><td></td><td></td><td></td><td>16</td><td>14</td><td>13</td><td>12</td><td>11</td><td>10</td><td>9</td><td></td><td>7</td><td>6</td><td></td><td>4</td><td>3</td><td>2</td><td></td><td></td></tr> </table>	72	71	70	69	68	67	66	65	64		62	61	60	59	58	57	56	55	54		52	51	50	49	48	46	44						40			37	36								32	31	30	29	28	27		25	24			21	20		18						16	14	13	12	11	10	9		7	6		4	3	2		
72	71	70	69	68	67	66	65	64		62	61	60	59	58	57	56	55	54																																																																					
52	51	50	49	48	46	44						40			37	36																																																																							
				32	31	30	29	28	27		25	24			21	20		18																																																																					
				16	14	13	12	11	10	9		7	6		4	3	2																																																																						
AVAILABLE	NOT APPLICABLE	34566-2823	G	0	A	BLACK	<table border="1"> <tr><td></td><td></td><td></td><td></td><td>67</td><td>66</td><td></td><td></td><td></td><td></td><td></td><td></td><td></td><td></td><td></td><td></td><td></td><td></td><td></td><td></td></tr> <tr><td></td><td></td><td></td><td></td><td>47</td><td></td><td></td><td></td><td></td><td></td><td></td><td>41</td><td></td><td></td><td></td><td></td><td></td><td></td><td></td><td></td></tr> <tr><td></td><td></td><td>73</td><td></td><td>32</td><td>31</td><td>30</td><td>29</td><td></td><td>27</td><td></td><td>25</td><td></td><td></td><td>22</td><td>21</td><td></td><td>19</td><td>18</td><td>17</td></tr> <tr><td></td><td></td><td></td><td></td><td>16</td><td>15</td><td>14</td><td>13</td><td></td><td></td><td>10</td><td>9</td><td>8</td><td>7</td><td>6</td><td>5</td><td>4</td><td>3</td><td>2</td><td>1</td></tr> </table>					67	66																			47							41											73		32	31	30	29		27		25			22	21		19	18	17					16	15	14	13			10	9	8	7	6	5	4	3	2	1
				67	66																																																																																		
				47							41																																																																												
		73		32	31	30	29		27		25			22	21		19	18	17																																																																				
				16	15	14	13			10	9	8	7	6	5	4	3	2	1																																																																				
AVAILABLE	NOT APPLICABLE	34566-2833	G	0	B	ST GRAY	<table border="1"> <tr><td>72</td><td>71</td><td>70</td><td>69</td><td>68</td><td>67</td><td>66</td><td>65</td><td></td><td></td><td>61</td><td>60</td><td></td><td></td><td>57</td><td>56</td><td>55</td><td>54</td><td></td><td></td></tr> <tr><td>52</td><td>51</td><td>50</td><td>49</td><td>48</td><td>46</td><td>44</td><td></td><td></td><td></td><td></td><td>40</td><td></td><td></td><td>37</td><td>36</td><td></td><td></td><td></td><td></td></tr> <tr><td></td><td></td><td></td><td></td><td>32</td><td>31</td><td>30</td><td>29</td><td>28</td><td>27</td><td></td><td>24</td><td></td><td></td><td>21</td><td>20</td><td></td><td>19</td><td>18</td><td>17</td></tr> <tr><td></td><td></td><td></td><td></td><td>16</td><td>14</td><td>13</td><td>12</td><td>11</td><td>10</td><td>9</td><td></td><td>7</td><td>6</td><td></td><td>4</td><td>3</td><td>2</td><td></td><td></td></tr> </table>	72	71	70	69	68	67	66	65			61	60			57	56	55	54			52	51	50	49	48	46	44					40			37	36									32	31	30	29	28	27		24			21	20		19	18	17					16	14	13	12	11	10	9		7	6		4	3	2		
72	71	70	69	68	67	66	65			61	60			57	56	55	54																																																																						
52	51	50	49	48	46	44					40			37	36																																																																								
				32	31	30	29	28	27		24			21	20		19	18	17																																																																				
				16	14	13	12	11	10	9		7	6		4	3	2																																																																						
AVAILABLE	NOT APPLICABLE	34566-2843	G	0	A	BLACK	<table border="1"> <tr><td></td><td></td><td></td><td></td><td>67</td><td>66</td><td></td><td></td><td></td><td></td><td></td><td></td><td></td><td></td><td></td><td></td><td></td><td></td><td></td><td></td></tr> <tr><td></td><td></td><td></td><td></td><td>47</td><td></td><td></td><td></td><td></td><td></td><td></td><td>41</td><td></td><td></td><td></td><td></td><td></td><td></td><td></td><td></td></tr> <tr><td></td><td></td><td>73</td><td></td><td>32</td><td>31</td><td>30</td><td>29</td><td></td><td>27</td><td></td><td>25</td><td></td><td></td><td>22</td><td>21</td><td></td><td>19</td><td>18</td><td>17</td></tr> <tr><td></td><td></td><td></td><td></td><td>16</td><td>15</td><td>14</td><td>13</td><td></td><td></td><td>10</td><td>9</td><td>8</td><td>7</td><td>6</td><td>5</td><td>4</td><td>3</td><td>2</td><td>1</td></tr> </table>					67	66																			47							41											73		32	31	30	29		27		25			22	21		19	18	17					16	15	14	13			10	9	8	7	6	5	4	3	2	1
				67	66																																																																																		
				47							41																																																																												
		73		32	31	30	29		27		25			22	21		19	18	17																																																																				
				16	15	14	13			10	9	8	7	6	5	4	3	2	1																																																																				
AVAILABLE	NOT APPLICABLE	34566-2853	G	0	B	ST GRAY	<table border="1"> <tr><td>72</td><td>71</td><td>70</td><td>69</td><td>68</td><td>67</td><td>66</td><td>65</td><td>64</td><td>63</td><td>61</td><td>60</td><td></td><td></td><td>57</td><td>56</td><td>55</td><td>54</td><td></td><td></td></tr> <tr><td>52</td><td>51</td><td>50</td><td>49</td><td>48</td><td>46</td><td>44</td><td></td><td></td><td></td><td></td><td>40</td><td></td><td></td><td>37</td><td>36</td><td></td><td></td><td></td><td></td></tr> <tr><td></td><td></td><td></td><td></td><td>32</td><td>31</td><td>30</td><td>29</td><td>28</td><td>27</td><td></td><td>24</td><td></td><td></td><td>21</td><td>20</td><td>19</td><td>18</td><td></td><td></td></tr> <tr><td></td><td></td><td></td><td></td><td>16</td><td>14</td><td>13</td><td>12</td><td>11</td><td>10</td><td>9</td><td></td><td>7</td><td>6</td><td></td><td>4</td><td>3</td><td>2</td><td></td><td></td></tr> </table>	72	71	70	69	68	67	66	65	64	63	61	60			57	56	55	54			52	51	50	49	48	46	44					40			37	36									32	31	30	29	28	27		24			21	20	19	18							16	14	13	12	11	10	9		7	6		4	3	2		
72	71	70	69	68	67	66	65	64	63	61	60			57	56	55	54																																																																						
52	51	50	49	48	46	44					40			37	36																																																																								
				32	31	30	29	28	27		24			21	20	19	18																																																																						
				16	14	13	12	11	10	9		7	6		4	3	2																																																																						
AVAILABLE	NOT APPLICABLE	34566-2863	G	0	A	BLACK	<table border="1"> <tr><td>72</td><td>71</td><td>70</td><td>69</td><td>68</td><td>67</td><td>66</td><td></td><td>64</td><td>63</td><td>62</td><td>60</td><td>59</td><td></td><td></td><td></td><td></td><td>55</td><td>54</td><td>53</td></tr> <tr><td>52</td><td></td><td></td><td>49</td><td>48</td><td>46</td><td>44</td><td>43</td><td>42</td><td></td><td></td><td>40</td><td>39</td><td></td><td></td><td></td><td></td><td>35</td><td>34</td><td>33</td></tr> <tr><td></td><td></td><td></td><td></td><td>32</td><td></td><td></td><td>29</td><td>28</td><td>27</td><td></td><td>24</td><td>23</td><td></td><td></td><td></td><td></td><td>19</td><td>18</td><td>17</td></tr> <tr><td></td><td></td><td></td><td></td><td>16</td><td>14</td><td>13</td><td>12</td><td>11</td><td></td><td>9</td><td>8</td><td>7</td><td>6</td><td>5</td><td>4</td><td>3</td><td>2</td><td>1</td><td></td></tr> </table>	72	71	70	69	68	67	66		64	63	62	60	59					55	54	53	52			49	48	46	44	43	42			40	39					35	34	33					32			29	28	27		24	23					19	18	17					16	14	13	12	11		9	8	7	6	5	4	3	2	1	
72	71	70	69	68	67	66		64	63	62	60	59					55	54	53																																																																				
52			49	48	46	44	43	42			40	39					35	34	33																																																																				
				32			29	28	27		24	23					19	18	17																																																																				
				16	14	13	12	11		9	8	7	6	5	4	3	2	1																																																																					
AVAILABLE	NOT APPLICABLE	34566-2873	G	0	B	ST GRAY	<table border="1"> <tr><td>72</td><td>71</td><td>70</td><td>69</td><td>68</td><td>67</td><td>66</td><td></td><td></td><td></td><td></td><td></td><td></td><td>59</td><td>58</td><td>57</td><td>56</td><td>55</td><td>53</td><td></td></tr> <tr><td>52</td><td>51</td><td>50</td><td>49</td><td>48</td><td>47</td><td></td><td></td><td></td><td></td><td></td><td></td><td></td><td>39</td><td>38</td><td>37</td><td>36</td><td>35</td><td>33</td><td></td></tr> <tr><td></td><td></td><td></td><td></td><td></td><td></td><td></td><td></td><td></td><td></td><td></td><td></td><td></td><td>23</td><td>22</td><td>21</td><td></td><td></td><td></td><td></td></tr> <tr><td></td><td></td><td></td><td></td><td></td><td>15</td><td></td><td></td><td></td><td>11</td><td>10</td><td>8</td><td></td><td>6</td><td>5</td><td>4</td><td>3</td><td></td><td></td><td></td></tr> </table>	72	71	70	69	68	67	66							59	58	57	56	55	53		52	51	50	49	48	47								39	38	37	36	35	33															23	22	21										15				11	10	8		6	5	4	3			
72	71	70	69	68	67	66							59	58	57	56	55	53																																																																					
52	51	50	49	48	47								39	38	37	36	35	33																																																																					
													23	22	21																																																																								
					15				11	10	8		6	5	4	3																																																																							
AVAILABLE	NOT APPLICABLE	34566-2883	G	0	A	BLACK	<table border="1"> <tr><td></td><td></td><td>70</td><td>69</td><td></td><td></td><td></td><td></td><td>63</td><td>62</td><td>61</td><td></td><td></td><td></td><td>58</td><td>57</td><td>56</td><td>55</td><td>54</td><td>53</td></tr> <tr><td>52</td><td>51</td><td></td><td>49</td><td></td><td></td><td></td><td></td><td>44</td><td>43</td><td>42</td><td>41</td><td></td><td></td><td></td><td></td><td>37</td><td>36</td><td>34</td><td></td></tr> <tr><td></td><td></td><td></td><td></td><td>32</td><td></td><td></td><td></td><td>29</td><td>28</td><td>27</td><td>26</td><td></td><td></td><td></td><td></td><td></td><td>19</td><td>18</td><td></td></tr> <tr><td></td><td></td><td></td><td></td><td>16</td><td></td><td></td><td></td><td>13</td><td>12</td><td>11</td><td>10</td><td></td><td></td><td></td><td></td><td></td><td>3</td><td></td><td></td></tr> </table>			70	69					63	62	61				58	57	56	55	54	53	52	51		49					44	43	42	41					37	36	34						32				29	28	27	26						19	18						16				13	12	11	10						3		
		70	69					63	62	61				58	57	56	55	54	53																																																																				
52	51		49					44	43	42	41					37	36	34																																																																					
				32				29	28	27	26						19	18																																																																					
				16				13	12	11	10						3																																																																						

ENTER DESCRIPTION IEC NO: UAU2014-0376 DRAWN BY: CHKD 2013/09/05 APPR: WJDSHY 2013/09/06 REV: GS	QUALITY SYMBOLS	GENERAL TOLERANCES (UNLESS SPECIFIED)	DIMENSION STYLE	SCALE	DESIGN UNITS	THIRD ANGLE PROJECTION	
	$\nabla=0$ $\nabla=0$ $\nabla=0$	4 PLACES ±--- INCH 3 PLACES ±--- INCH 2 PLACES ±--- INCH 1 PLACE ±--- INCH 0 PLACE ±--- INCH	mm INCH ANGULAR ±--- DRAFT WHERE APPLICABLE MUST REMAIN WITHIN DIMENSIONS	MM ONLY		METRIC	SKRA JENDRANA 2011/02/14 MVANSLAMBROU 2011/02/14
	MATERIAL NO. SD-34566-001		DOCUMENT NO. SD-34566-001		TITLE MX123 66/73/80CKT HRNS CONN ASSY		SHEET NO. 33 OF 68
	THIS DRAWING CONTAINS INFORMATION THAT IS PROPRIETARY TO MOLEX INCORPORATED AND SHOULD NOT BE USED WITHOUT WRITTEN PERMISSION						SIZE D

STATUS	GM PART #	MATERIAL #	PART/MATERIAL REVISION	WIRE DRESS OPTION	KEY OPTION	COLOR (TPA)	NUMBERS INDICATE CAVITIES OPEN FOR CIRCUITS																																																																	
AVAILABLE	NOT APPLICABLE	34566-2893	G	0	A	BLACK	<table border="1"> <tr><td>72</td><td></td><td>69</td><td>67</td><td>65</td><td>63</td><td></td><td>60</td><td></td><td>57</td><td>56</td><td></td><td>53</td></tr> <tr><td></td><td></td><td>49</td><td>47</td><td>46</td><td>44</td><td>43</td><td></td><td>40</td><td></td><td>37</td><td>36</td><td>35</td><td>33</td></tr> <tr><td></td><td>73</td><td></td><td>31</td><td>30</td><td>29</td><td>28</td><td></td><td>24</td><td></td><td>21</td><td>20</td><td></td><td>17</td></tr> <tr><td></td><td></td><td></td><td>16</td><td>15</td><td>14</td><td>13</td><td></td><td>11</td><td>10</td><td></td><td>5</td><td>4</td><td>3</td><td>2</td><td>1</td></tr> </table>	72		69	67	65	63		60		57	56		53			49	47	46	44	43		40		37	36	35	33		73		31	30	29	28		24		21	20		17				16	15	14	13		11	10		5	4	3	2	1								
72		69	67	65	63		60		57	56		53																																																												
		49	47	46	44	43		40		37	36	35	33																																																											
	73		31	30	29	28		24		21	20		17																																																											
			16	15	14	13		11	10		5	4	3	2	1																																																									
AVAILABLE	NOT APPLICABLE	34566-2913	G	0	B	ST GRAY	<table border="1"> <tr><td></td><td></td><td>68</td><td>67</td><td></td><td>64</td><td></td><td></td><td></td><td>58</td><td></td><td></td><td></td><td></td><td></td><td></td></tr> <tr><td></td><td></td><td></td><td></td><td>46</td><td>45</td><td></td><td></td><td></td><td>38</td><td></td><td></td><td></td><td></td><td></td><td></td></tr> <tr><td></td><td>73</td><td></td><td>32</td><td>30</td><td>29</td><td>28</td><td>27</td><td></td><td></td><td>22</td><td></td><td></td><td></td><td></td><td>17</td></tr> <tr><td></td><td></td><td></td><td></td><td>15</td><td>14</td><td>13</td><td></td><td>10</td><td></td><td></td><td></td><td></td><td></td><td></td><td>1</td></tr> </table>			68	67		64				58											46	45				38								73		32	30	29	28	27			22					17					15	14	13		10							1	
		68	67		64				58																																																															
				46	45				38																																																															
	73		32	30	29	28	27			22					17																																																									
				15	14	13		10							1																																																									
AVAILABLE	NOT APPLICABLE	34566-2923	G	0	B	ST GRAY	<table border="1"> <tr><td></td><td></td><td>68</td><td>67</td><td></td><td>64</td><td></td><td></td><td></td><td></td><td></td><td></td><td></td><td></td><td></td><td></td></tr> <tr><td></td><td></td><td></td><td></td><td>46</td><td>45</td><td></td><td></td><td></td><td></td><td></td><td></td><td></td><td></td><td></td><td></td></tr> <tr><td></td><td>73</td><td></td><td>32</td><td>30</td><td>29</td><td>28</td><td>27</td><td></td><td></td><td></td><td></td><td></td><td></td><td></td><td>17</td></tr> <tr><td></td><td></td><td></td><td></td><td>15</td><td>14</td><td>13</td><td></td><td>10</td><td></td><td></td><td></td><td></td><td></td><td></td><td></td></tr> </table>			68	67		64															46	45												73		32	30	29	28	27								17					15	14	13		10								
		68	67		64																																																																			
				46	45																																																																			
	73		32	30	29	28	27								17																																																									
				15	14	13		10																																																																
AVAILABLE	NOT APPLICABLE	34566-2933	G	0	A	BLACK	<table border="1"> <tr><td>72</td><td></td><td>69</td><td>67</td><td>65</td><td>63</td><td></td><td>60</td><td></td><td>57</td><td>56</td><td></td><td>53</td></tr> <tr><td></td><td></td><td>49</td><td>47</td><td>46</td><td>44</td><td>43</td><td></td><td>40</td><td></td><td>37</td><td>36</td><td>35</td><td>33</td></tr> <tr><td></td><td>73</td><td></td><td>31</td><td>30</td><td>29</td><td>28</td><td></td><td>24</td><td></td><td>21</td><td>20</td><td></td><td>17</td></tr> <tr><td></td><td></td><td></td><td>16</td><td>15</td><td>14</td><td>13</td><td></td><td>11</td><td>10</td><td></td><td>5</td><td>4</td><td>3</td><td>2</td><td>1</td></tr> </table>	72		69	67	65	63		60		57	56		53			49	47	46	44	43		40		37	36	35	33		73		31	30	29	28		24		21	20		17				16	15	14	13		11	10		5	4	3	2	1								
72		69	67	65	63		60		57	56		53																																																												
		49	47	46	44	43		40		37	36	35	33																																																											
	73		31	30	29	28		24		21	20		17																																																											
			16	15	14	13		11	10		5	4	3	2	1																																																									
AVAILABLE	NOT APPLICABLE	34566-2943	G	0	B	ST GRAY	<table border="1"> <tr><td></td><td></td><td>68</td><td>67</td><td></td><td>64</td><td>63</td><td></td><td></td><td>59</td><td>57</td><td></td><td></td><td></td><td></td><td></td></tr> <tr><td></td><td></td><td></td><td></td><td>46</td><td>45</td><td>43</td><td></td><td></td><td>39</td><td>37</td><td></td><td></td><td></td><td></td><td></td></tr> <tr><td></td><td>73</td><td></td><td>32</td><td>30</td><td>29</td><td>28</td><td>27</td><td></td><td></td><td>21</td><td></td><td></td><td></td><td></td><td></td></tr> <tr><td></td><td></td><td></td><td></td><td></td><td></td><td></td><td></td><td>10</td><td></td><td>6</td><td>5</td><td>4</td><td>3</td><td></td><td></td></tr> </table>			68	67		64	63			59	57										46	45	43			39	37							73		32	30	29	28	27			21														10		6	5	4	3			
		68	67		64	63			59	57																																																														
				46	45	43			39	37																																																														
	73		32	30	29	28	27			21																																																														
								10		6	5	4	3																																																											
AVAILABLE	NOT APPLICABLE	34566-2953	G	0	B	ST GRAY	<table border="1"> <tr><td></td><td></td><td>68</td><td>67</td><td></td><td>64</td><td>63</td><td></td><td></td><td>59</td><td></td><td></td><td></td><td></td><td></td><td>34</td></tr> <tr><td></td><td></td><td></td><td></td><td>46</td><td>45</td><td>43</td><td></td><td></td><td>39</td><td></td><td></td><td></td><td></td><td></td><td></td></tr> <tr><td></td><td>73</td><td></td><td>32</td><td>30</td><td>29</td><td>28</td><td>27</td><td></td><td></td><td></td><td></td><td></td><td></td><td></td><td></td></tr> <tr><td></td><td></td><td></td><td></td><td></td><td></td><td></td><td></td><td>10</td><td></td><td>6</td><td>5</td><td>4</td><td>3</td><td></td><td></td></tr> </table>			68	67		64	63			59						34					46	45	43			39								73		32	30	29	28	27																	10		6	5	4	3			
		68	67		64	63			59						34																																																									
				46	45	43			39																																																															
	73		32	30	29	28	27																																																																	
								10		6	5	4	3																																																											
AVAILABLE	NOT APPLICABLE	34566-2963	G	0	H	ST GRAY	<table border="1"> <tr><td></td><td>79</td><td></td><td></td><td>74</td><td>73</td><td>72</td><td>71</td><td>69</td><td>68</td><td>67</td><td></td><td>64</td><td>62</td><td>61</td></tr> <tr><td></td><td>59</td><td></td><td></td><td>54</td><td>53</td><td>52</td><td></td><td>49</td><td>48</td><td>47</td><td></td><td></td><td>42</td><td>41</td></tr> <tr><td></td><td></td><td>38</td><td></td><td></td><td>33</td><td></td><td></td><td>29</td><td>27</td><td>25</td><td></td><td></td><td></td><td>21</td></tr> <tr><td></td><td></td><td></td><td></td><td>15</td><td>14</td><td></td><td>11</td><td>10</td><td>9</td><td>8</td><td>7</td><td></td><td></td><td></td></tr> </table>		79			74	73	72	71	69	68	67		64	62	61		59			54	53	52		49	48	47			42	41			38			33			29	27	25				21					15	14		11	10	9	8	7								
	79			74	73	72	71	69	68	67		64	62	61																																																										
	59			54	53	52		49	48	47			42	41																																																										
		38			33			29	27	25				21																																																										
				15	14		11	10	9	8	7																																																													
AVAILABLE	NOT APPLICABLE	34566-2973	G	0	G	BLUE	<table border="1"> <tr><td>80</td><td>78</td><td>77</td><td>75</td><td>74</td><td>73</td><td>72</td><td>70</td><td>69</td><td>67</td><td>65</td><td>64</td><td>63</td><td>62</td><td></td><td></td></tr> <tr><td>60</td><td>58</td><td>57</td><td></td><td>55</td><td>54</td><td>52</td><td>51</td><td>50</td><td>49</td><td>47</td><td>45</td><td></td><td></td><td></td><td></td></tr> <tr><td>40</td><td>38</td><td>37</td><td></td><td></td><td></td><td>33</td><td>32</td><td>31</td><td></td><td></td><td>27</td><td>26</td><td>25</td><td>24</td><td></td></tr> <tr><td>20</td><td>18</td><td>17</td><td></td><td></td><td></td><td></td><td></td><td>10</td><td>9</td><td>8</td><td>6</td><td>5</td><td></td><td>3</td><td>2</td><td>1</td></tr> </table>	80	78	77	75	74	73	72	70	69	67	65	64	63	62			60	58	57		55	54	52	51	50	49	47	45					40	38	37				33	32	31			27	26	25	24		20	18	17						10	9	8	6	5		3	2	1
80	78	77	75	74	73	72	70	69	67	65	64	63	62																																																											
60	58	57		55	54	52	51	50	49	47	45																																																													
40	38	37				33	32	31			27	26	25	24																																																										
20	18	17						10	9	8	6	5		3	2	1																																																								

ENTER DESCRIPTION IEC NO: UAU2014-0376 DRAWN BY: CHKO APPR: IKOSHY 2013/09/05 2013/09/06 REV	QUALITY SYMBOLS	GENERAL TOLERANCES (UNLESS SPECIFIED)	DIMENSION STYLE	SCALE	DESIGN UNITS	THIRD ANGLE PROJECTION	
	∇=0 ∇=0 ∇=0	4 PLACES ±--- INCH 3 PLACES ±--- INCH 2 PLACES ±--- INCH 1 PLACE ±--- INCH 0 PLACE ±--- INCH	mm INCH	MM ONLY		METRIC	SKRA JENDRANA 2011/02/14 MVANSLAMBROU 2011/02/14
	ANGULAR ±---° DRAFT WHERE APPLICABLE MUST REMAIN WITHIN DIMENSIONS	SEE BOM TABLE	MATERIAL NO. DOCUMENT NO.	DATE DATE DATE	TITLE MX123 66/73/80CKT HRNS CONN ASSY	SHEET NO. 34 OF 68	molex
	THIS DRAWING CONTAINS INFORMATION THAT IS PROPRIETARY TO MOLEX INCORPORATED AND SHOULD NOT BE USED WITHOUT WRITTEN PERMISSION						

STATUS	GM PART #	MATERIAL #	PART/MATERIAL REVISION	WIRE DRESS OPTION	KEY OPTION	COLOR (TPA)	NUMBERS INDICATE CAVITIES OPEN FOR CIRCUITS																																																																																										
AVAILABLE	NOT APPLICABLE	34566-9913	G	0	A	BLACK	<table border="1"> <tr><td>72</td><td>71</td><td></td><td>68</td><td>67</td><td>66</td><td>65</td><td>64</td><td></td><td></td><td></td><td>59</td><td></td><td></td><td></td><td></td><td></td><td></td></tr> <tr><td></td><td>50</td><td></td><td>48</td><td>47</td><td>46</td><td>45</td><td></td><td></td><td></td><td></td><td>40</td><td>39</td><td>38</td><td></td><td></td><td></td><td></td></tr> <tr><td>73</td><td></td><td></td><td>31</td><td>30</td><td></td><td></td><td></td><td></td><td></td><td>25</td><td>24</td><td>22</td><td>21</td><td>20</td><td></td><td></td><td>17</td></tr> <tr><td></td><td></td><td></td><td></td><td>14</td><td></td><td></td><td></td><td></td><td></td><td>9</td><td>7</td><td>6</td><td>5</td><td>4</td><td></td><td>2</td><td>1</td></tr> </table>	72	71		68	67	66	65	64				59								50		48	47	46	45					40	39	38					73			31	30						25	24	22	21	20			17					14						9	7	6	5	4		2	1																		
72	71		68	67	66	65	64				59																																																																																						
	50		48	47	46	45					40	39	38																																																																																				
73			31	30						25	24	22	21	20			17																																																																																
				14						9	7	6	5	4		2	1																																																																																
AVAILABLE	NOT APPLICABLE	34566-9923	G	0	A	BLACK	<table border="1"> <tr><td>72</td><td>71</td><td></td><td></td><td>67</td><td>66</td><td></td><td></td><td></td><td></td><td>62</td><td>61</td><td>60</td><td></td><td>57</td><td>55</td><td>54</td><td></td></tr> <tr><td></td><td>51</td><td></td><td></td><td>48</td><td>46</td><td>45</td><td>44</td><td>43</td><td>42</td><td></td><td></td><td>39</td><td></td><td></td><td></td><td>35</td><td>33</td></tr> <tr><td>73</td><td></td><td></td><td></td><td></td><td></td><td></td><td></td><td></td><td></td><td>26</td><td>25</td><td>24</td><td></td><td></td><td></td><td></td><td></td></tr> <tr><td></td><td></td><td></td><td></td><td></td><td>15</td><td>14</td><td></td><td></td><td></td><td></td><td>8</td><td>7</td><td>6</td><td>5</td><td>4</td><td>3</td><td>2</td></tr> </table>	72	71			67	66					62	61	60		57	55	54			51			48	46	45	44	43	42			39				35	33	73										26	25	24											15	14					8	7	6	5	4	3	2																		
72	71			67	66					62	61	60		57	55	54																																																																																	
	51			48	46	45	44	43	42			39				35	33																																																																																
73										26	25	24																																																																																					
					15	14					8	7	6	5	4	3	2																																																																																
AVAILABLE	NOT APPLICABLE	34566-9933	G	0	B	ST GRAY	<table border="1"> <tr><td></td><td></td><td></td><td></td><td>69</td><td></td><td></td><td>65</td><td>64</td><td>63</td><td></td><td></td><td></td><td></td><td></td><td></td><td></td><td></td></tr> <tr><td></td><td></td><td></td><td></td><td>49</td><td></td><td></td><td>45</td><td>44</td><td>43</td><td></td><td></td><td></td><td></td><td></td><td></td><td>22</td><td>21</td></tr> <tr><td>73</td><td></td><td></td><td></td><td></td><td></td><td></td><td></td><td></td><td></td><td></td><td></td><td></td><td></td><td></td><td>20</td><td>19</td><td>18</td></tr> <tr><td></td><td></td><td></td><td></td><td></td><td></td><td></td><td></td><td></td><td></td><td></td><td></td><td></td><td></td><td></td><td>6</td><td>5</td><td>4</td></tr> <tr><td></td><td></td><td></td><td></td><td></td><td></td><td></td><td></td><td>12</td><td>11</td><td></td><td></td><td></td><td></td><td></td><td>3</td><td>2</td><td>1</td></tr> </table>					69			65	64	63													49			45	44	43							22	21	73															20	19	18																6	5	4									12	11						3	2	1
				69			65	64	63																																																																																								
				49			45	44	43							22	21																																																																																
73															20	19	18																																																																																
															6	5	4																																																																																
								12	11						3	2	1																																																																																
AVAILABLE	NOT APPLICABLE	34566-9943	G	0	C	BLUE	<table border="1"> <tr><td></td><td>71</td><td>69</td><td></td><td></td><td></td><td>65</td><td>64</td><td></td><td></td><td>61</td><td>60</td><td></td><td>58</td><td></td><td>56</td><td>55</td><td>54</td></tr> <tr><td></td><td>50</td><td>49</td><td></td><td></td><td></td><td>45</td><td>43</td><td></td><td>41</td><td></td><td></td><td></td><td></td><td>37</td><td>36</td><td>35</td><td></td></tr> <tr><td>73</td><td></td><td></td><td></td><td></td><td>31</td><td>29</td><td>28</td><td></td><td></td><td>24</td><td>23</td><td></td><td></td><td></td><td></td><td>19</td><td>18</td></tr> <tr><td></td><td></td><td></td><td></td><td></td><td>16</td><td></td><td>13</td><td>12</td><td>11</td><td></td><td>8</td><td>7</td><td></td><td></td><td></td><td>3</td><td>2</td></tr> <tr><td></td><td></td><td></td><td></td><td></td><td></td><td></td><td></td><td></td><td></td><td></td><td></td><td></td><td></td><td></td><td></td><td></td><td>1</td></tr> </table>		71	69				65	64			61	60		58		56	55	54		50	49				45	43		41					37	36	35		73					31	29	28			24	23					19	18						16		13	12	11		8	7				3	2																		1
	71	69				65	64			61	60		58		56	55	54																																																																																
	50	49				45	43		41					37	36	35																																																																																	
73					31	29	28			24	23					19	18																																																																																
					16		13	12	11		8	7				3	2																																																																																
																	1																																																																																
AVAILABLE	NOT APPLICABLE	34566-9953	G	0	A	BLACK	<table border="1"> <tr><td></td><td></td><td></td><td></td><td>67</td><td></td><td></td><td></td><td></td><td></td><td>62</td><td></td><td>60</td><td></td><td>57</td><td>55</td><td></td><td></td></tr> <tr><td></td><td>51</td><td></td><td></td><td>48</td><td>46</td><td>45</td><td>44</td><td>43</td><td></td><td></td><td></td><td>39</td><td></td><td></td><td></td><td>35</td><td></td></tr> <tr><td>73</td><td></td><td></td><td></td><td></td><td></td><td></td><td></td><td></td><td></td><td></td><td>25</td><td></td><td></td><td></td><td></td><td></td><td></td></tr> <tr><td></td><td></td><td></td><td></td><td></td><td>15</td><td>14</td><td></td><td></td><td></td><td></td><td></td><td>7</td><td>6</td><td>5</td><td>4</td><td>3</td><td>2</td></tr> </table>					67						62		60		57	55				51			48	46	45	44	43				39				35		73											25												15	14						7	6	5	4	3	2																		
				67						62		60		57	55																																																																																		
	51			48	46	45	44	43				39				35																																																																																	
73											25																																																																																						
					15	14						7	6	5	4	3	2																																																																																
AVAILABLE	NOT APPLICABLE	34566-9963	G	0	B	ST GRAY	<table border="1"> <tr><td></td><td></td><td></td><td></td><td>68</td><td>67</td><td></td><td></td><td>64</td><td>63</td><td></td><td></td><td></td><td></td><td>58</td><td></td><td>55</td><td></td></tr> <tr><td></td><td></td><td></td><td></td><td></td><td></td><td></td><td>46</td><td>45</td><td>43</td><td></td><td></td><td></td><td></td><td></td><td>38</td><td>35</td><td></td></tr> <tr><td>73</td><td></td><td></td><td></td><td>32</td><td>30</td><td>29</td><td>28</td><td>27</td><td></td><td></td><td></td><td></td><td></td><td>22</td><td>19</td><td>17</td><td></td></tr> <tr><td></td><td></td><td></td><td></td><td></td><td>15</td><td>13</td><td></td><td></td><td>10</td><td></td><td></td><td></td><td></td><td></td><td></td><td></td><td>1</td></tr> </table>					68	67			64	63					58		55									46	45	43						38	35		73				32	30	29	28	27						22	19	17							15	13			10								1																		
				68	67			64	63					58		55																																																																																	
							46	45	43						38	35																																																																																	
73				32	30	29	28	27						22	19	17																																																																																	
					15	13			10								1																																																																																
AVAILABLE	NOT APPLICABLE	34566-9973	G	0	B	ST GRAY	<table border="1"> <tr><td></td><td></td><td></td><td></td><td>68</td><td>67</td><td></td><td></td><td>64</td><td>63</td><td></td><td></td><td></td><td></td><td>58</td><td></td><td></td><td></td></tr> <tr><td></td><td></td><td></td><td></td><td></td><td></td><td></td><td>46</td><td>45</td><td>43</td><td></td><td></td><td></td><td></td><td>38</td><td></td><td></td><td></td></tr> <tr><td>73</td><td></td><td></td><td></td><td>32</td><td>30</td><td>29</td><td>28</td><td>27</td><td></td><td></td><td></td><td></td><td></td><td>22</td><td></td><td></td><td>17</td></tr> <tr><td></td><td></td><td></td><td></td><td></td><td>15</td><td>13</td><td></td><td></td><td>10</td><td></td><td></td><td></td><td></td><td></td><td></td><td></td><td></td></tr> </table>					68	67			64	63					58											46	45	43					38				73				32	30	29	28	27						22			17						15	13			10																										
				68	67			64	63					58																																																																																			
							46	45	43					38																																																																																			
73				32	30	29	28	27						22			17																																																																																
					15	13			10																																																																																								

ENTER DESCRIPTION IEC NO: UAU2014-0376 DRAWN BY: CHKD APPR: WKSHY 2013/09/05 2013/09/06 DESCRIPTION:	QUALITY SYMBOLS ∇=0 ∇=0 ∇=0	GENERAL TOLERANCES (UNLESS SPECIFIED)		DIMENSION STYLE MM ONLY	SCALE DESIGN UNITS METRIC	THIRD ANGLE PROJECTION
		4 PLACES # --- # --- 3 PLACES # --- # --- 2 PLACES # --- # --- 1 PLACE # --- # --- 0 PLACE # --- # ---		DATE SKRA JENDRANA 2011/02/14	DATE MVANSLAMBROU 2011/02/14	
ANGULAR ± ---° DRAFT WHERE APPLICABLE MUST REMAIN WITHIN DIMENSIONS		MATERIAL NO. SEE BOM TABLE		DOCUMENT NO. SD-34566-001		SHEET NO. 35 OF 68

MX123
66/73/80CKT
HRNS CONN ASSY
molex

THIS DRAWING CONTAINS INFORMATION THAT IS PROPRIETARY TO MOLEX INCORPORATED AND SHOULD NOT BE USED WITHOUT WRITTEN PERMISSION

STATUS	GM PART #	MATERIAL #	PART/MATERIAL REVISION	WIRE DRESS OPTION	KEY OPTION	COLOR (TPA)	NUMBERS INDICATE CAVITIES OPEN FOR CIRCUITS																																																																																								
AVAILABLE	NOT APPLICABLE	34566-2983	G	9	A	BLACK	<table border="1"> <tr><td></td><td></td><td>70</td><td>69</td><td></td><td></td><td></td><td></td><td></td><td></td><td>63</td><td>62</td><td>61</td><td></td><td></td><td>58</td><td>57</td><td>56</td><td>55</td><td>54</td><td>53</td></tr> <tr><td>52</td><td>51</td><td></td><td>49</td><td></td><td></td><td></td><td></td><td></td><td></td><td>44</td><td>43</td><td>42</td><td>41</td><td></td><td></td><td>37</td><td>36</td><td></td><td></td><td>34</td></tr> <tr><td></td><td></td><td></td><td></td><td>73</td><td></td><td></td><td></td><td></td><td></td><td></td><td></td><td></td><td></td><td></td><td></td><td></td><td></td><td></td><td>19</td><td>18</td><td>17</td></tr> <tr><td></td><td></td><td></td><td></td><td></td><td></td><td></td><td></td><td></td><td></td><td></td><td></td><td></td><td></td><td></td><td></td><td></td><td></td><td></td><td>3</td><td>2</td><td>1</td></tr> </table>			70	69							63	62	61			58	57	56	55	54	53	52	51		49							44	43	42	41			37	36			34					73															19	18	17																				3	2	1		
		70	69							63	62	61			58	57	56	55	54	53																																																																											
52	51		49							44	43	42	41			37	36			34																																																																											
				73															19	18	17																																																																										
																			3	2	1																																																																										
AVAILABLE	NOT APPLICABLE	34566-2993	G	9	B	ST GRY	<table border="1"> <tr><td>72</td><td>71</td><td>70</td><td></td><td>68</td><td>67</td><td>66</td><td></td><td></td><td></td><td>62</td><td>61</td><td>60</td><td>59</td><td>58</td><td>57</td><td>56</td><td>55</td><td>54</td><td>53</td></tr> <tr><td>52</td><td>51</td><td>50</td><td></td><td>48</td><td>47</td><td>46</td><td></td><td></td><td></td><td>42</td><td>41</td><td>40</td><td>39</td><td>38</td><td>37</td><td>36</td><td>35</td><td>34</td><td>33</td></tr> <tr><td></td><td></td><td></td><td></td><td></td><td></td><td></td><td></td><td></td><td></td><td></td><td></td><td></td><td></td><td></td><td></td><td></td><td></td><td></td><td></td><td></td></tr> <tr><td></td><td></td><td></td><td></td><td></td><td></td><td></td><td></td><td></td><td></td><td></td><td></td><td></td><td></td><td></td><td></td><td></td><td></td><td></td><td></td><td></td></tr> </table>	72	71	70		68	67	66				62	61	60	59	58	57	56	55	54	53	52	51	50		48	47	46				42	41	40	39	38	37	36	35	34	33																																																
72	71	70		68	67	66				62	61	60	59	58	57	56	55	54	53																																																																												
52	51	50		48	47	46				42	41	40	39	38	37	36	35	34	33																																																																												
AVAILABLE	NOT APPLICABLE	34566-3013	G	9	C	BLUE	<table border="1"> <tr><td>72</td><td>71</td><td>70</td><td>69</td><td>68</td><td>67</td><td>66</td><td></td><td></td><td></td><td>63</td><td>62</td><td></td><td>59</td><td></td><td>57</td><td>56</td><td>55</td><td></td><td>53</td></tr> <tr><td>52</td><td>51</td><td></td><td></td><td></td><td></td><td></td><td></td><td></td><td></td><td>46</td><td>44</td><td></td><td>42</td><td>40</td><td>39</td><td>38</td><td></td><td></td><td>34</td><td>33</td></tr> <tr><td></td><td></td><td></td><td></td><td></td><td></td><td></td><td></td><td></td><td></td><td></td><td></td><td></td><td></td><td></td><td></td><td></td><td></td><td></td><td></td><td></td></tr> <tr><td></td><td></td><td></td><td></td><td></td><td></td><td></td><td></td><td></td><td></td><td></td><td></td><td></td><td></td><td></td><td></td><td></td><td></td><td></td><td></td><td></td></tr> </table>	72	71	70	69	68	67	66				63	62		59		57	56	55		53	52	51									46	44		42	40	39	38			34	33																																															
72	71	70	69	68	67	66				63	62		59		57	56	55		53																																																																												
52	51									46	44		42	40	39	38			34	33																																																																											
AVAILABLE	NOT APPLICABLE	34566-3023	G	0	G	BLUE	<table border="1"> <tr><td></td><td>79</td><td></td><td></td><td>76</td><td></td><td></td><td></td><td></td><td></td><td>71</td><td></td><td></td><td>68</td><td></td><td>66</td><td></td><td></td><td></td><td></td><td>61</td></tr> <tr><td></td><td>59</td><td></td><td></td><td>56</td><td></td><td></td><td>53</td><td></td><td></td><td></td><td></td><td></td><td>48</td><td></td><td>46</td><td></td><td>44</td><td>43</td><td>42</td><td>41</td></tr> <tr><td></td><td>39</td><td></td><td></td><td>36</td><td>35</td><td>34</td><td></td><td></td><td></td><td></td><td>30</td><td>29</td><td>28</td><td></td><td></td><td></td><td></td><td></td><td>23</td><td>22</td><td>21</td></tr> <tr><td></td><td>19</td><td></td><td></td><td>16</td><td>15</td><td>14</td><td>13</td><td>12</td><td>11</td><td></td><td></td><td></td><td>7</td><td></td><td></td><td></td><td></td><td></td><td></td><td></td><td></td></tr> </table>		79			76						71			68		66					61		59			56			53						48		46		44	43	42	41		39			36	35	34					30	29	28						23	22	21		19			16	15	14	13	12	11				7										
	79			76						71			68		66					61																																																																											
	59			56			53						48		46		44	43	42	41																																																																											
	39			36	35	34					30	29	28						23	22	21																																																																										
	19			16	15	14	13	12	11				7																																																																																		
AVAILABLE	NOT APPLICABLE	34566-3033	G	0	H	ST GRY	<table border="1"> <tr><td>80</td><td>78</td><td>77</td><td>76</td><td>75</td><td></td><td></td><td></td><td></td><td></td><td>70</td><td></td><td></td><td></td><td></td><td>66</td><td>65</td><td></td><td>63</td><td></td><td></td></tr> <tr><td>60</td><td>58</td><td>57</td><td>56</td><td>55</td><td></td><td></td><td></td><td></td><td></td><td>51</td><td>50</td><td></td><td></td><td></td><td>46</td><td>45</td><td>44</td><td>43</td><td></td><td></td></tr> <tr><td>40</td><td>39</td><td></td><td>37</td><td>36</td><td>35</td><td>34</td><td></td><td></td><td></td><td>32</td><td>31</td><td>30</td><td></td><td>28</td><td></td><td>26</td><td></td><td>24</td><td>23</td><td>22</td></tr> <tr><td>20</td><td>19</td><td>18</td><td>17</td><td>16</td><td></td><td></td><td></td><td></td><td></td><td></td><td></td><td></td><td></td><td></td><td>6</td><td>5</td><td>4</td><td>3</td><td>2</td><td>1</td></tr> </table>	80	78	77	76	75						70					66	65		63			60	58	57	56	55						51	50				46	45	44	43			40	39		37	36	35	34				32	31	30		28		26		24	23	22	20	19	18	17	16											6	5	4	3	2	1				
80	78	77	76	75						70					66	65		63																																																																													
60	58	57	56	55						51	50				46	45	44	43																																																																													
40	39		37	36	35	34				32	31	30		28		26		24	23	22																																																																											
20	19	18	17	16											6	5	4	3	2	1																																																																											
AVAILABLE	NOT APPLICABLE	34566-3043	G	0	C	BLUE	<table border="1"> <tr><td>72</td><td>70</td><td></td><td>68</td><td></td><td>66</td><td></td><td></td><td></td><td></td><td>63</td><td>62</td><td></td><td>59</td><td></td><td>57</td><td></td><td></td><td></td><td></td><td>53</td></tr> <tr><td>52</td><td>51</td><td></td><td>48</td><td>47</td><td>46</td><td></td><td></td><td></td><td></td><td>44</td><td>42</td><td></td><td>40</td><td>39</td><td></td><td></td><td></td><td></td><td></td><td>34</td><td>33</td></tr> <tr><td></td><td></td><td></td><td></td><td></td><td></td><td></td><td></td><td></td><td></td><td></td><td></td><td></td><td></td><td></td><td></td><td></td><td></td><td></td><td></td><td></td><td></td></tr> <tr><td></td><td></td><td></td><td></td><td></td><td></td><td></td><td></td><td></td><td></td><td></td><td></td><td></td><td></td><td></td><td></td><td></td><td></td><td></td><td></td><td></td><td></td></tr> </table>	72	70		68		66					63	62		59		57					53	52	51		48	47	46					44	42		40	39						34	33																																													
72	70		68		66					63	62		59		57					53																																																																											
52	51		48	47	46					44	42		40	39						34	33																																																																										
AVAILABLE	NOT APPLICABLE	34566-3053	G	0	C	BLUE	<table border="1"> <tr><td>72</td><td>70</td><td></td><td>68</td><td></td><td>66</td><td></td><td></td><td></td><td></td><td>63</td><td>62</td><td></td><td>59</td><td></td><td>57</td><td></td><td></td><td></td><td></td><td>53</td></tr> <tr><td>52</td><td>51</td><td></td><td>48</td><td>47</td><td>46</td><td></td><td></td><td></td><td></td><td>44</td><td>42</td><td></td><td>40</td><td>39</td><td>38</td><td></td><td></td><td></td><td></td><td>34</td><td>33</td></tr> <tr><td></td><td></td><td></td><td></td><td></td><td></td><td></td><td></td><td></td><td></td><td></td><td></td><td></td><td></td><td></td><td></td><td></td><td></td><td></td><td></td><td></td><td></td></tr> <tr><td></td><td></td><td></td><td></td><td></td><td></td><td></td><td></td><td></td><td></td><td></td><td></td><td></td><td></td><td></td><td></td><td></td><td></td><td></td><td></td><td></td><td></td></tr> </table>	72	70		68		66					63	62		59		57					53	52	51		48	47	46					44	42		40	39	38					34	33																																													
72	70		68		66					63	62		59		57					53																																																																											
52	51		48	47	46					44	42		40	39	38					34	33																																																																										
AVAILABLE	NOT APPLICABLE	34566-3063	G	0	A	BLACK	<table border="1"> <tr><td></td><td>71</td><td></td><td>69</td><td></td><td></td><td></td><td></td><td></td><td></td><td>65</td><td>64</td><td>63</td><td></td><td></td><td>60</td><td>58</td><td>57</td><td>56</td><td>55</td><td>54</td><td>53</td></tr> <tr><td>52</td><td>51</td><td></td><td>49</td><td></td><td></td><td></td><td></td><td></td><td></td><td>45</td><td>44</td><td>43</td><td>42</td><td>41</td><td></td><td></td><td>37</td><td>36</td><td>35</td><td>34</td><td>33</td></tr> <tr><td></td><td></td><td></td><td></td><td></td><td></td><td></td><td></td><td></td><td></td><td></td><td></td><td></td><td></td><td></td><td></td><td></td><td></td><td></td><td></td><td></td><td></td></tr> <tr><td></td><td></td><td></td><td></td><td></td><td></td><td></td><td></td><td></td><td></td><td></td><td></td><td></td><td></td><td></td><td></td><td></td><td></td><td></td><td></td><td></td><td></td></tr> </table>		71		69							65	64	63			60	58	57	56	55	54	53	52	51		49							45	44	43	42	41			37	36	35	34	33																																												
	71		69							65	64	63			60	58	57	56	55	54	53																																																																										
52	51		49							45	44	43	42	41			37	36	35	34	33																																																																										

ENTER DESCRIPTION IEC NO: UAU2014-0376 DRAWN BY: 2013/09/05 CHKD: 2013/09/06 APPR: WOSHY REV: 05	QUALITY SYMBOLS	GENERAL TOLERANCES (UNLESS SPECIFIED)	DIMENSION STYLE	SCALE	DESIGN UNITS	THIRD ANGLE PROJECTION	
	$\nabla=0$ $\nabla=0$ $\nabla=0$	4 PLACES ±---+--- 3 PLACES ±---+--- 2 PLACES ±---+--- 1 PLACE ±---+--- 0 PLACE ±---+---	mm INCH ±---+--- ±---+--- ±---+--- ±---+--- ±---+--- ±---+--- ±---+--- ±---+---	MM ONLY		METRIC	
		ANGULAR ±---+--- DRAFT WHERE APPLICABLE MUST REMAIN WITHIN DIMENSIONS	DRAWN BY: SKRAJENDRANA 2011/02/14 CHECKED BY: MYANSLAMBROU 2011/02/14 APPROVED BY:	DATE	DATE	DATE	MX123 66/73/80CKT HRNS CONN ASSY
				SEE BOM TABLE			MATERIAL NO. SD-34566-001 DOCUMENT NO. 36 OF 68 THIS DRAWING CONTAINS INFORMATION THAT IS PROPRIETARY TO MOLEX INCORPORATED AND SHOULD NOT BE USED WITHOUT WRITTEN PERMISSION

STATUS	GM PART #	MATERIAL #	PART/MATERIAL REVISION	WIRE DRESS OPTION	KEY OPTION	COLOR (TPA)	NUMBERS INDICATE CAVITIES OPEN FOR CIRCUITS															
AVAILABLE	NOT APPLICABLE	34566-3073	G	0	A	BLACK	71	69			65	64	63		60		57	56	55	54	53	
							52	51	49			45	44	43	42	41		37	36	35	34	33
							73			32	30		28	26		23				19	18	
									16			12	10		8	7	6			3		
AVAILABLE	NOT APPLICABLE	34566-3083	G	0	A	BLACK	71	69			65	64	63		60		58	57	56	55	54	53
							52	51	49			45	44	43	42	41		37	36	35	34	33
							73			32	30		28	26						19	18	
									16			11	10							3		
AVAILABLE	NOT APPLICABLE	34566-3093	G	0	A	BLACK	71	69			64	63	62		60		57	56	55	54	53	
							52	51	49			45	44	43	42	41		37	36	35	34	33
							73			32	30		28	26		23				19	18	
									16			12	10							3		
AVAILABLE	NOT APPLICABLE	34566-3113	G	0	A	BLACK	71	69			65	64	63		60		57	56	55	54	53	
							52	51	49			45	44	43	42	41		37	36	35	34	33
							73			32	30		28	26		23	21			19	18	
									16			12	10		8		5			3		
AVAILABLE	NOT APPLICABLE	34566-3123	G	0	B	ST GRY	72	70	68	66					60	59			55	54	53	
							52	50	48	46					40	39			35	34	33	
							73			32	31	30	29	28	27	26	25	24				
									16					10	9	8						
AVAILABLE	NOT APPLICABLE	34566-3133	G	0	C	BLUE	72	70	68	67	66			63	62		59	57			53	
							52	51		48	47	46		44	42	40	39				34	33
							73			32		30			26	25		22	21	20		
									15	14				10	9		6	5	4			
AVAILABLE	NOT APPLICABLE	34566-3143	G	0	C	BLUE	72	70			66			63	62		59	57			53	
							52	51			46	44		42	40	39		37	36		34	33
							73			32		30			26	25		22	21			
									15	14				10	9		6					
AVAILABLE	NOT APPLICABLE	34566-3153	G	0	A	BLACK		70	69						63			58	56		54	
							52	51	49		47			44	43	42	41			36	34	
							73			32			28	26						19	18	
									16				12	10						3		

ENTER DESCRIPTION IEC NO: UAU2014-0376 DRAWN BY: CHKO CHKD: APPR:IKOSHY 2013/09/05 2013/09/06 65	QUALITY SYMBOLS ∇=0 ∇=0 ∇=0	GENERAL TOLERANCES (UNLESS SPECIFIED): 4 PLACES ±---+--- 3 PLACES ±---+--- 2 PLACES ±---+--- 1 PLACE ±---+--- 0 PLACE ±---+---	DIMENSION STYLE MM ONLY	SCALE DESIGN UNITS METRIC	THIRD ANGLE PROJECTION	
	ANGULAR ±---° DRAFT WHERE APPLICABLE MUST REMAIN WITHIN DIMENSIONS	DRAWN BY: SKRAJENDRANA 2011/02/14 CHECKED BY: MYANSLAMBROU 2011/02/14 APPROVED BY:	DATE:	TITLE MX123 66/73/80CKT HRNS CONN ASSY	MATERIAL NO. SEE BOM TABLE	DOCUMENT NO. SD-34566-001
	SHEET NO. 37 OF 68	THIS DRAWING CONTAINS INFORMATION THAT IS PROPRIETARY TO MOLEX INCORPORATED AND SHOULD NOT BE USED WITHOUT WRITTEN PERMISSION				

STATUS	GM PART #	MATERIAL #	PART/MATERIAL REVISION	WIRE DRESS OPTION	KEY OPTION	COLOR (TPA)	NUMBERS INDICATE CAVITIES OPEN FOR CIRCUITS																																																																			
AVAILABLE	NOT APPLICABLE	34566-3163	G	0	C	BLUE	<table border="1"> <tr><td>72</td><td>70</td><td></td><td></td><td></td><td></td><td>63</td><td>62</td><td></td><td>59</td><td>57</td><td>56</td><td>55</td><td>53</td></tr> <tr><td>52</td><td>51</td><td></td><td></td><td></td><td>46</td><td>44</td><td>42</td><td>40</td><td>39</td><td>37</td><td>36</td><td></td><td>34</td><td>33</td></tr> <tr><td></td><td></td><td>73</td><td></td><td></td><td>32</td><td>30</td><td></td><td>26</td><td>25</td><td></td><td>22</td><td>21</td><td>19</td><td>18</td></tr> <tr><td></td><td></td><td></td><td></td><td></td><td>15</td><td>14</td><td></td><td>10</td><td>9</td><td></td><td>6</td><td></td><td>3</td><td></td></tr> </table>	72	70					63	62		59	57	56	55	53	52	51				46	44	42	40	39	37	36		34	33			73			32	30		26	25		22	21	19	18						15	14		10	9		6		3									
72	70					63	62		59	57	56	55	53																																																													
52	51				46	44	42	40	39	37	36		34	33																																																												
		73			32	30		26	25		22	21	19	18																																																												
					15	14		10	9		6		3																																																													
AVAILABLE	NOT APPLICABLE	34566-3173	G	0	A	BLACK	<table border="1"> <tr><td></td><td>70</td><td>69</td><td></td><td></td><td></td><td>63</td><td></td><td></td><td></td><td>58</td><td>56</td><td>55</td><td>54</td><td></td></tr> <tr><td>52</td><td>51</td><td></td><td>49</td><td></td><td></td><td>44</td><td>43</td><td>42</td><td>41</td><td></td><td></td><td>36</td><td></td><td>34</td></tr> <tr><td></td><td></td><td>73</td><td></td><td></td><td>32</td><td></td><td>28</td><td>26</td><td></td><td></td><td></td><td></td><td>19</td><td>18</td></tr> <tr><td></td><td></td><td></td><td></td><td></td><td>16</td><td></td><td>12</td><td>10</td><td></td><td></td><td></td><td></td><td>3</td><td>2</td></tr> </table>		70	69				63				58	56	55	54		52	51		49			44	43	42	41			36		34			73			32		28	26					19	18						16		12	10					3	2							
	70	69				63				58	56	55	54																																																													
52	51		49			44	43	42	41			36		34																																																												
		73			32		28	26					19	18																																																												
					16		12	10					3	2																																																												
AVAILABLE	NOT APPLICABLE	34566-3183	G	0	C	BLUE	<table border="1"> <tr><td>72</td><td>70</td><td></td><td></td><td></td><td>66</td><td></td><td>63</td><td>62</td><td></td><td>59</td><td>57</td><td>56</td><td>55</td><td>53</td></tr> <tr><td>52</td><td>51</td><td></td><td></td><td></td><td>46</td><td>44</td><td>42</td><td>40</td><td>39</td><td></td><td></td><td></td><td></td><td>34</td><td>33</td></tr> <tr><td></td><td></td><td>73</td><td></td><td></td><td>30</td><td></td><td></td><td>26</td><td>25</td><td></td><td>22</td><td>21</td><td></td><td></td><td></td></tr> <tr><td></td><td></td><td></td><td></td><td></td><td>15</td><td>14</td><td></td><td>10</td><td>9</td><td></td><td>6</td><td></td><td></td><td></td><td></td></tr> </table>	72	70				66		63	62		59	57	56	55	53	52	51				46	44	42	40	39					34	33			73			30			26	25		22	21									15	14		10	9		6								
72	70				66		63	62		59	57	56	55	53																																																												
52	51				46	44	42	40	39					34	33																																																											
		73			30			26	25		22	21																																																														
					15	14		10	9		6																																																															
AVAILABLE	NOT APPLICABLE	34566-3193	G	0	A	BLACK	<table border="1"> <tr><td></td><td></td><td>69</td><td></td><td></td><td></td><td>63</td><td></td><td></td><td></td><td>58</td><td>56</td><td>55</td><td>54</td><td>53</td></tr> <tr><td>52</td><td>51</td><td></td><td>49</td><td></td><td></td><td>44</td><td>43</td><td>42</td><td>41</td><td></td><td></td><td>36</td><td>35</td><td>34</td><td>33</td></tr> <tr><td></td><td></td><td>73</td><td></td><td></td><td>32</td><td></td><td>28</td><td>26</td><td></td><td></td><td></td><td></td><td>19</td><td>18</td><td>17</td></tr> <tr><td></td><td></td><td></td><td></td><td></td><td>16</td><td></td><td>12</td><td>10</td><td></td><td></td><td></td><td></td><td>3</td><td>2</td><td>1</td></tr> </table>			69				63				58	56	55	54	53	52	51		49			44	43	42	41			36	35	34	33			73			32		28	26					19	18	17						16		12	10					3	2	1				
		69				63				58	56	55	54	53																																																												
52	51		49			44	43	42	41			36	35	34	33																																																											
		73			32		28	26					19	18	17																																																											
					16		12	10					3	2	1																																																											
AVAILABLE	NOT APPLICABLE	34566-3213	G	0	C	BLUE	<table border="1"> <tr><td>72</td><td>70</td><td></td><td></td><td></td><td>67</td><td>66</td><td></td><td>63</td><td>62</td><td></td><td>59</td><td></td><td>56</td><td></td><td>53</td></tr> <tr><td>52</td><td>51</td><td></td><td></td><td></td><td>46</td><td>44</td><td></td><td>42</td><td>40</td><td></td><td></td><td></td><td></td><td></td><td>34</td><td>33</td></tr> <tr><td></td><td></td><td>73</td><td></td><td></td><td>32</td><td>30</td><td></td><td></td><td>26</td><td>25</td><td></td><td>22</td><td>21</td><td></td><td></td><td></td></tr> <tr><td></td><td></td><td></td><td></td><td></td><td>15</td><td>14</td><td></td><td></td><td>10</td><td>9</td><td></td><td>6</td><td>5</td><td>4</td><td></td><td></td></tr> </table>	72	70				67	66		63	62		59		56		53	52	51				46	44		42	40						34	33			73			32	30			26	25		22	21									15	14			10	9		6	5	4		
72	70				67	66		63	62		59		56		53																																																											
52	51				46	44		42	40						34	33																																																										
		73			32	30			26	25		22	21																																																													
					15	14			10	9		6	5	4																																																												
AVAILABLE	NOT APPLICABLE	34566-3223	G	0	C	BLUE	<table border="1"> <tr><td>72</td><td>70</td><td></td><td></td><td></td><td>67</td><td>66</td><td></td><td>63</td><td>62</td><td></td><td>59</td><td>57</td><td></td><td></td><td>53</td></tr> <tr><td>52</td><td>51</td><td></td><td></td><td></td><td>46</td><td>44</td><td></td><td>42</td><td>40</td><td>39</td><td></td><td></td><td></td><td></td><td>34</td><td>33</td></tr> <tr><td></td><td></td><td>73</td><td></td><td></td><td>32</td><td>30</td><td></td><td>27</td><td>26</td><td>25</td><td></td><td>22</td><td>21</td><td></td><td></td><td></td></tr> <tr><td></td><td></td><td></td><td></td><td></td><td>15</td><td>14</td><td></td><td></td><td>10</td><td>9</td><td></td><td>6</td><td>5</td><td>4</td><td></td><td></td></tr> </table>	72	70				67	66		63	62		59	57			53	52	51				46	44		42	40	39					34	33			73			32	30		27	26	25		22	21									15	14			10	9		6	5	4		
72	70				67	66		63	62		59	57			53																																																											
52	51				46	44		42	40	39					34	33																																																										
		73			32	30		27	26	25		22	21																																																													
					15	14			10	9		6	5	4																																																												
AVAILABLE	NOT APPLICABLE	34566-3233	G	0	A	BLACK	<table border="1"> <tr><td></td><td>70</td><td>69</td><td></td><td></td><td></td><td>63</td><td>62</td><td>61</td><td></td><td>58</td><td>57</td><td>56</td><td>55</td><td>54</td><td>53</td></tr> <tr><td>52</td><td>51</td><td></td><td>49</td><td></td><td></td><td>44</td><td>43</td><td>42</td><td>41</td><td></td><td></td><td>37</td><td>36</td><td></td><td>34</td></tr> <tr><td></td><td></td><td>73</td><td></td><td></td><td>32</td><td></td><td>29</td><td>28</td><td>27</td><td>26</td><td></td><td></td><td></td><td>19</td><td>18</td></tr> <tr><td></td><td></td><td></td><td></td><td></td><td>16</td><td>15</td><td>13</td><td>12</td><td>11</td><td>10</td><td></td><td></td><td></td><td>3</td><td></td></tr> </table>		70	69				63	62	61		58	57	56	55	54	53	52	51		49			44	43	42	41			37	36		34			73			32		29	28	27	26				19	18						16	15	13	12	11	10				3				
	70	69				63	62	61		58	57	56	55	54	53																																																											
52	51		49			44	43	42	41			37	36		34																																																											
		73			32		29	28	27	26				19	18																																																											
					16	15	13	12	11	10				3																																																												
AVAILABLE	NOT APPLICABLE	34566-3243	G	0	C	BLUE	<table border="1"> <tr><td>72</td><td>70</td><td></td><td></td><td></td><td>66</td><td></td><td>63</td><td>62</td><td></td><td>59</td><td>57</td><td></td><td></td><td></td><td>53</td></tr> <tr><td>52</td><td>51</td><td></td><td></td><td></td><td>46</td><td>44</td><td></td><td>42</td><td>40</td><td>39</td><td></td><td></td><td></td><td></td><td>34</td><td>33</td></tr> <tr><td></td><td></td><td>73</td><td></td><td></td><td>32</td><td>30</td><td></td><td></td><td>26</td><td>25</td><td></td><td>22</td><td>21</td><td></td><td></td><td></td></tr> <tr><td></td><td></td><td></td><td></td><td></td><td>15</td><td>14</td><td></td><td></td><td>10</td><td>9</td><td></td><td>6</td><td>5</td><td>4</td><td></td><td></td></tr> </table>	72	70				66		63	62		59	57				53	52	51				46	44		42	40	39					34	33			73			32	30			26	25		22	21									15	14			10	9		6	5	4		
72	70				66		63	62		59	57				53																																																											
52	51				46	44		42	40	39					34	33																																																										
		73			32	30			26	25		22	21																																																													
					15	14			10	9		6	5	4																																																												

ENTER DESCRIPTION IEC NO: UAU2014-0376 DRAWN BY: 2013/09/05 CHKD: 2013/09/06 APPR: WJOSH REV: 05	QUALITY SYMBOLS ∇=0 ∇=0 ∇=0	GENERAL TOLERANCES (UNLESS SPECIFIED) <table border="1"> <tr><td></td><td>mm</td><td>INCH</td></tr> <tr><td>4 PLACES</td><td>±----</td><td>±----</td></tr> <tr><td>3 PLACES</td><td>±----</td><td>±----</td></tr> <tr><td>2 PLACES</td><td>±----</td><td>±----</td></tr> <tr><td>1 PLACE</td><td>±----</td><td>±----</td></tr> <tr><td>0 PLACE</td><td>±----</td><td>±----</td></tr> </table>		mm	INCH	4 PLACES	±----	±----	3 PLACES	±----	±----	2 PLACES	±----	±----	1 PLACE	±----	±----	0 PLACE	±----	±----	DIMENSION STYLE MM ONLY	SCALE METRIC	DESIGN UNITS METRIC	THIRD ANGLE PROJECTION
		mm	INCH																					
	4 PLACES	±----	±----																					
	3 PLACES	±----	±----																					
2 PLACES	±----	±----																						
1 PLACE	±----	±----																						
0 PLACE	±----	±----																						
DESCRIPTION SKRAJENDRANA 2011/02/14 MYANSLAMBROU 2011/02/14	DATE SKRAJENDRANA 2011/02/14 MYANSLAMBROU 2011/02/14	TITLE MX123 66/73/80CKT HRNS CONN ASSY	molex MATERIAL NO. SD-34566-001 DOCUMENT NO. SD-34566-001 SHEET NO. 38 OF 68																					
ANGULAR ±---- DRAFT WHERE APPLICABLE MUST REMAIN WITHIN DIMENSIONS	SIZE SEE BOM TABLE	THIS DRAWING CONTAINS INFORMATION THAT IS PROPRIETARY TO MOLEX INCORPORATED AND SHOULD NOT BE USED WITHOUT WRITTEN PERMISSION																						

STATUS	GM PART #	MATERIAL #	PART/MATERIAL REVISION	WIRE DRESS OPTION	KEY OPTION	COLOR (TPA)	NUMBERS INDICATE CAVITIES OPEN FOR CIRCUITS																																																																								
AVAILABLE	NOT APPLICABLE	34566-3253	G	0	A	BLACK	<table border="1"> <tr><td></td><td>70</td><td>69</td><td></td><td></td><td></td><td>63</td><td></td><td></td><td></td><td>58</td><td>56</td><td>55</td><td>54</td><td>53</td></tr> <tr><td>52</td><td>51</td><td>49</td><td></td><td></td><td></td><td>44</td><td>43</td><td>42</td><td>41</td><td></td><td></td><td>36</td><td>34</td><td></td></tr> <tr><td></td><td></td><td>73</td><td>32</td><td></td><td></td><td>28</td><td>26</td><td></td><td></td><td></td><td></td><td>19</td><td>18</td><td></td></tr> <tr><td></td><td></td><td></td><td>16</td><td>15</td><td></td><td>12</td><td>10</td><td></td><td></td><td></td><td></td><td>3</td><td></td><td></td></tr> </table>		70	69				63				58	56	55	54	53	52	51	49				44	43	42	41			36	34				73	32			28	26					19	18					16	15		12	10					3														
	70	69				63				58	56	55	54	53																																																																	
52	51	49				44	43	42	41			36	34																																																																		
		73	32			28	26					19	18																																																																		
			16	15		12	10					3																																																																			
AVAILABLE	NOT APPLICABLE	34566-3263	G	0	C	BLUE	<table border="1"> <tr><td>72</td><td>70</td><td></td><td></td><td>66</td><td></td><td>63</td><td>62</td><td></td><td></td><td>59</td><td>57</td><td>56</td><td>55</td><td>53</td></tr> <tr><td>52</td><td>51</td><td></td><td></td><td>46</td><td>44</td><td>42</td><td>40</td><td>39</td><td></td><td></td><td></td><td></td><td>34</td><td>33</td></tr> <tr><td></td><td></td><td>73</td><td>32</td><td>30</td><td></td><td>26</td><td>25</td><td></td><td></td><td>22</td><td>21</td><td>19</td><td>18</td><td></td></tr> <tr><td></td><td></td><td></td><td>15</td><td>14</td><td></td><td>10</td><td>9</td><td></td><td></td><td>6</td><td>5</td><td>4</td><td>3</td><td></td></tr> </table>	72	70			66		63	62			59	57	56	55	53	52	51			46	44	42	40	39					34	33			73	32	30		26	25			22	21	19	18					15	14		10	9			6	5	4	3													
72	70			66		63	62			59	57	56	55	53																																																																	
52	51			46	44	42	40	39					34	33																																																																	
		73	32	30		26	25			22	21	19	18																																																																		
			15	14		10	9			6	5	4	3																																																																		
AVAILABLE	NOT APPLICABLE	34566-3273	G	0	A	BLACK	<table border="1"> <tr><td></td><td>70</td><td>69</td><td></td><td></td><td></td><td>63</td><td></td><td></td><td></td><td>58</td><td>56</td><td>55</td><td>54</td><td>53</td></tr> <tr><td>52</td><td>51</td><td>49</td><td></td><td></td><td></td><td>44</td><td>43</td><td>42</td><td>41</td><td></td><td></td><td>36</td><td>34</td><td></td></tr> <tr><td></td><td></td><td>73</td><td>32</td><td></td><td></td><td>28</td><td>26</td><td></td><td></td><td></td><td></td><td>19</td><td>18</td><td>17</td></tr> <tr><td></td><td></td><td></td><td>16</td><td>15</td><td></td><td>12</td><td>10</td><td></td><td></td><td></td><td></td><td>3</td><td>2</td><td>1</td></tr> </table>		70	69				63				58	56	55	54	53	52	51	49				44	43	42	41			36	34				73	32			28	26					19	18	17				16	15		12	10					3	2	1												
	70	69				63				58	56	55	54	53																																																																	
52	51	49				44	43	42	41			36	34																																																																		
		73	32			28	26					19	18	17																																																																	
			16	15		12	10					3	2	1																																																																	
AVAILABLE	NOT APPLICABLE	34566-3283	G	0	C	BLUE	<table border="1"> <tr><td>72</td><td>70</td><td></td><td>67</td><td>66</td><td></td><td>63</td><td>62</td><td></td><td></td><td>59</td><td>57</td><td></td><td></td><td>53</td></tr> <tr><td>52</td><td>51</td><td></td><td></td><td>46</td><td>44</td><td>42</td><td>40</td><td>39</td><td></td><td></td><td></td><td></td><td>34</td><td>33</td></tr> <tr><td></td><td></td><td>73</td><td></td><td>30</td><td></td><td>26</td><td>25</td><td></td><td></td><td>22</td><td>21</td><td></td><td></td><td></td></tr> <tr><td></td><td></td><td></td><td>15</td><td>14</td><td></td><td>10</td><td>9</td><td></td><td></td><td>6</td><td>5</td><td>4</td><td></td><td></td></tr> </table>	72	70		67	66		63	62			59	57			53	52	51			46	44	42	40	39					34	33			73		30		26	25			22	21							15	14		10	9			6	5	4														
72	70		67	66		63	62			59	57			53																																																																	
52	51			46	44	42	40	39					34	33																																																																	
		73		30		26	25			22	21																																																																				
			15	14		10	9			6	5	4																																																																			
AVAILABLE	NOT APPLICABLE	34566-3293	G	0	B	ST GRAY	<table border="1"> <tr><td>72</td><td>71</td><td>70</td><td>68</td><td>67</td><td>66</td><td></td><td></td><td>62</td><td>61</td><td>60</td><td>59</td><td>58</td><td>57</td><td>56</td><td>55</td><td>54</td><td>53</td></tr> <tr><td>52</td><td>51</td><td>50</td><td>48</td><td>47</td><td></td><td></td><td></td><td>42</td><td>41</td><td>40</td><td>39</td><td>38</td><td>37</td><td>36</td><td>35</td><td>34</td><td>33</td></tr> <tr><td></td><td></td><td>73</td><td>32</td><td>31</td><td>30</td><td>29</td><td>28</td><td>27</td><td>26</td><td>25</td><td>24</td><td>23</td><td></td><td></td><td></td><td></td><td></td></tr> <tr><td></td><td></td><td></td><td>16</td><td>15</td><td>14</td><td>13</td><td></td><td></td><td>10</td><td>9</td><td>8</td><td></td><td></td><td></td><td></td><td></td><td></td></tr> </table>	72	71	70	68	67	66			62	61	60	59	58	57	56	55	54	53	52	51	50	48	47				42	41	40	39	38	37	36	35	34	33			73	32	31	30	29	28	27	26	25	24	23									16	15	14	13			10	9	8						
72	71	70	68	67	66			62	61	60	59	58	57	56	55	54	53																																																														
52	51	50	48	47				42	41	40	39	38	37	36	35	34	33																																																														
		73	32	31	30	29	28	27	26	25	24	23																																																																			
			16	15	14	13			10	9	8																																																																				
AVAILABLE	NOT APPLICABLE	34566-3313	G	0	C	BLUE	<table border="1"> <tr><td>72</td><td>70</td><td></td><td></td><td></td><td></td><td>63</td><td>62</td><td></td><td></td><td>59</td><td>57</td><td></td><td></td><td>53</td></tr> <tr><td>52</td><td>51</td><td></td><td></td><td>46</td><td>44</td><td>42</td><td>40</td><td>39</td><td></td><td></td><td></td><td></td><td>34</td><td>33</td></tr> <tr><td></td><td></td><td>73</td><td>32</td><td>30</td><td></td><td>26</td><td>25</td><td></td><td></td><td>22</td><td>21</td><td></td><td></td><td></td></tr> <tr><td></td><td></td><td></td><td>15</td><td>14</td><td></td><td></td><td></td><td></td><td></td><td>6</td><td>5</td><td>4</td><td></td><td></td></tr> </table>	72	70					63	62			59	57			53	52	51			46	44	42	40	39					34	33			73	32	30		26	25			22	21							15	14						6	5	4														
72	70					63	62			59	57			53																																																																	
52	51			46	44	42	40	39					34	33																																																																	
		73	32	30		26	25			22	21																																																																				
			15	14						6	5	4																																																																			
AVAILABLE	NOT APPLICABLE	34566-3323	G	0	B	ST GRAY	<table border="1"> <tr><td></td><td></td><td></td><td>68</td><td>67</td><td>66</td><td>65</td><td>64</td><td>63</td><td></td><td></td><td></td><td>58</td><td></td><td>55</td><td></td><td></td><td></td></tr> <tr><td></td><td></td><td>49</td><td>48</td><td>46</td><td>45</td><td>44</td><td>43</td><td></td><td></td><td></td><td></td><td>38</td><td></td><td></td><td></td><td></td><td></td></tr> <tr><td></td><td></td><td>73</td><td>32</td><td>30</td><td>29</td><td>28</td><td>27</td><td></td><td></td><td></td><td>22</td><td></td><td></td><td></td><td></td><td></td><td>17</td></tr> <tr><td></td><td></td><td></td><td>16</td><td></td><td></td><td></td><td></td><td>10</td><td></td><td></td><td></td><td></td><td></td><td></td><td></td><td></td><td></td></tr> </table>				68	67	66	65	64	63				58		55						49	48	46	45	44	43					38								73	32	30	29	28	27				22						17				16					10									
			68	67	66	65	64	63				58		55																																																																	
		49	48	46	45	44	43					38																																																																			
		73	32	30	29	28	27				22						17																																																														
			16					10																																																																							
AVAILABLE	NOT APPLICABLE	34566-3333	G	0	A	BLACK	<table border="1"> <tr><td>72</td><td>71</td><td>70</td><td>69</td><td>68</td><td></td><td>65</td><td>64</td><td>63</td><td></td><td>61</td><td>59</td><td>58</td><td>57</td><td>56</td><td></td><td>54</td><td></td></tr> <tr><td>52</td><td>51</td><td>50</td><td>49</td><td>47</td><td></td><td></td><td></td><td>42</td><td>41</td><td></td><td></td><td>38</td><td>37</td><td>36</td><td></td><td>34</td><td>33</td></tr> <tr><td></td><td></td><td>73</td><td>32</td><td>31</td><td>30</td><td>29</td><td>28</td><td>27</td><td>26</td><td></td><td>24</td><td>23</td><td></td><td></td><td>20</td><td>19</td><td>18</td></tr> <tr><td></td><td></td><td></td><td>16</td><td></td><td></td><td>13</td><td>12</td><td>11</td><td>10</td><td>9</td><td></td><td></td><td></td><td></td><td>3</td><td>2</td><td>1</td></tr> </table>	72	71	70	69	68		65	64	63		61	59	58	57	56		54		52	51	50	49	47				42	41			38	37	36		34	33			73	32	31	30	29	28	27	26		24	23			20	19	18				16			13	12	11	10	9					3	2	1
72	71	70	69	68		65	64	63		61	59	58	57	56		54																																																															
52	51	50	49	47				42	41			38	37	36		34	33																																																														
		73	32	31	30	29	28	27	26		24	23			20	19	18																																																														
			16			13	12	11	10	9					3	2	1																																																														

ENTER DESCRIPTION IEC NO: UAU2014-0376 DRAWN BY: 2013/09/05 CHKD: 2013/09/06 APPR: IKOSHY REV: 05	QUALITY SYMBOLS	GENERAL TOLERANCES (UNLESS SPECIFIED)	DIMENSION STYLE	SCALE	DESIGN UNITS	THIRD ANGLE PROJECTION
	$\nabla=0$ $\nabla=0$ $\nabla=0$	4 PLACES ±--- mm 3 PLACES ±--- INCH 2 PLACES ±--- 1 PLACE ±--- 0 PLACE ±---	MM ONLY	MM ONLY	METRIC	
			DRAWN BY: SKRA JENDRANA 2011/02/14 CHECKED BY: MVANSLAMBROU 2011/02/14 APPROVED BY:	DATE	DATE	DATE
			MATERIAL NO. SEE BOM TABLE DRAFT WHERE APPLICABLE MUST REMAIN WITHIN DIMENSIONS		DOCUMENT NO. SD-34566-001 SHEET NO. 39 OF 68	TITLE MX123 66/73/80CKT HRNS CONN ASSY molex

STATUS	GM PART #	MATERIAL #	PART / MATERIAL REVISION	WIRE DRESS OPTION	KEY OPTION	COLOR (TPA)	NUMBERS INDICATE CAVITIES OPEN FOR CIRCUITS																																																																			
AVAILABLE	NOT APPLICABLE	34566-3343	G	0	A	BLACK	<table border="1"> <tr><td>72</td><td></td><td>69</td><td>67</td><td>66</td><td>65</td><td>63</td><td></td><td>60</td><td></td><td>57</td><td>56</td><td></td><td>53</td></tr> <tr><td></td><td></td><td>49</td><td>47</td><td></td><td>44</td><td>43</td><td>42</td><td>40</td><td></td><td>37</td><td>36</td><td>35</td><td>33</td></tr> <tr><td>73</td><td></td><td></td><td>31</td><td>30</td><td>29</td><td>28</td><td>26</td><td>24</td><td></td><td>21</td><td>20</td><td></td><td>17</td></tr> <tr><td></td><td></td><td>16</td><td>15</td><td>14</td><td>13</td><td></td><td>11</td><td>10</td><td></td><td></td><td>5</td><td>4</td><td>3</td><td>2</td><td>1</td></tr> </table>	72		69	67	66	65	63		60		57	56		53			49	47		44	43	42	40		37	36	35	33	73			31	30	29	28	26	24		21	20		17			16	15	14	13		11	10			5	4	3	2	1									
72		69	67	66	65	63		60		57	56		53																																																													
		49	47		44	43	42	40		37	36	35	33																																																													
73			31	30	29	28	26	24		21	20		17																																																													
		16	15	14	13		11	10			5	4	3	2	1																																																											
AVAILABLE	NOT APPLICABLE	34566-3353	G	0	B	ST GRAY	<table border="1"> <tr><td></td><td></td><td>68</td><td>67</td><td></td><td>64</td><td></td><td></td><td></td><td>59</td><td>58</td><td></td><td></td><td>54</td></tr> <tr><td></td><td></td><td></td><td>46</td><td>45</td><td></td><td></td><td></td><td></td><td>39</td><td>38</td><td></td><td></td><td></td></tr> <tr><td>73</td><td></td><td>32</td><td>30</td><td>29</td><td>28</td><td>27</td><td></td><td></td><td>23</td><td>22</td><td></td><td></td><td>17</td></tr> <tr><td></td><td></td><td></td><td></td><td></td><td>12</td><td>10</td><td></td><td>8</td><td></td><td></td><td></td><td></td><td></td><td></td><td>1</td></tr> </table>			68	67		64				59	58			54				46	45					39	38				73		32	30	29	28	27			23	22			17						12	10		8							1									
		68	67		64				59	58			54																																																													
			46	45					39	38																																																																
73		32	30	29	28	27			23	22			17																																																													
					12	10		8							1																																																											
AVAILABLE	NOT APPLICABLE	34566-3363	G	0	A	BLACK	<table border="1"> <tr><td>71</td><td>69</td><td>68</td><td></td><td>65</td><td>64</td><td>63</td><td></td><td>61</td><td></td><td>59</td><td>57</td><td>56</td><td>54</td></tr> <tr><td>52</td><td>50</td><td>49</td><td>47</td><td></td><td></td><td></td><td></td><td>42</td><td>41</td><td>40</td><td>39</td><td>38</td><td>37</td><td>36</td><td>34</td><td>33</td></tr> <tr><td>73</td><td></td><td></td><td>32</td><td>31</td><td>30</td><td>29</td><td>28</td><td>27</td><td>26</td><td>24</td><td>23</td><td>22</td><td></td><td>20</td><td>19</td><td>18</td></tr> <tr><td></td><td></td><td></td><td>16</td><td></td><td></td><td>13</td><td>12</td><td>11</td><td>10</td><td>9</td><td></td><td></td><td></td><td></td><td></td><td>1</td></tr> </table>	71	69	68		65	64	63		61		59	57	56	54	52	50	49	47					42	41	40	39	38	37	36	34	33	73			32	31	30	29	28	27	26	24	23	22		20	19	18				16			13	12	11	10	9						1		
71	69	68		65	64	63		61		59	57	56	54																																																													
52	50	49	47					42	41	40	39	38	37	36	34	33																																																										
73			32	31	30	29	28	27	26	24	23	22		20	19	18																																																										
			16			13	12	11	10	9						1																																																										
AVAILABLE	NOT APPLICABLE	34566-3373	G	9	C	BLUE	<table border="1"> <tr><td>72</td><td>70</td><td>68</td><td>67</td><td>66</td><td></td><td>63</td><td>62</td><td></td><td>59</td><td>57</td><td>56</td><td>55</td><td>53</td></tr> <tr><td>52</td><td>51</td><td></td><td>48</td><td>47</td><td>46</td><td>44</td><td>42</td><td></td><td>40</td><td>39</td><td>38</td><td></td><td>34</td><td>33</td></tr> <tr><td>73</td><td></td><td></td><td>32</td><td>30</td><td></td><td></td><td>26</td><td>25</td><td></td><td></td><td>22</td><td>21</td><td>19</td><td>18</td></tr> <tr><td></td><td></td><td></td><td>15</td><td>14</td><td></td><td></td><td>10</td><td>9</td><td></td><td></td><td>6</td><td>5</td><td>4</td><td>3</td><td></td></tr> </table>	72	70	68	67	66		63	62		59	57	56	55	53	52	51		48	47	46	44	42		40	39	38		34	33	73			32	30			26	25			22	21	19	18				15	14			10	9			6	5	4	3								
72	70	68	67	66		63	62		59	57	56	55	53																																																													
52	51		48	47	46	44	42		40	39	38		34	33																																																												
73			32	30			26	25			22	21	19	18																																																												
			15	14			10	9			6	5	4	3																																																												
AVAILABLE	NOT APPLICABLE	34566-3383	G	0	A	BLACK	<table border="1"> <tr><td></td><td>70</td><td>69</td><td>68</td><td></td><td>65</td><td>64</td><td>63</td><td></td><td>61</td><td></td><td>59</td><td>58</td><td>57</td><td>56</td><td>54</td></tr> <tr><td>52</td><td>50</td><td>49</td><td>48</td><td>47</td><td></td><td></td><td></td><td>42</td><td>41</td><td></td><td></td><td>38</td><td>37</td><td>36</td><td>34</td><td>33</td></tr> <tr><td>73</td><td></td><td></td><td>32</td><td>31</td><td>30</td><td>29</td><td>28</td><td>27</td><td>26</td><td></td><td>24</td><td>23</td><td></td><td>20</td><td>19</td><td>18</td></tr> <tr><td></td><td></td><td></td><td>16</td><td></td><td></td><td>13</td><td>12</td><td>11</td><td>10</td><td>9</td><td></td><td></td><td></td><td></td><td></td><td>1</td></tr> </table>		70	69	68		65	64	63		61		59	58	57	56	54	52	50	49	48	47				42	41			38	37	36	34	33	73			32	31	30	29	28	27	26		24	23		20	19	18				16			13	12	11	10	9						1
	70	69	68		65	64	63		61		59	58	57	56	54																																																											
52	50	49	48	47				42	41			38	37	36	34	33																																																										
73			32	31	30	29	28	27	26		24	23		20	19	18																																																										
			16			13	12	11	10	9						1																																																										
AVAILABLE	NOT APPLICABLE	34566-3393	G	0	C	BLUE	<table border="1"> <tr><td>72</td><td>70</td><td></td><td>68</td><td>67</td><td>66</td><td></td><td>63</td><td>62</td><td></td><td>59</td><td>57</td><td></td><td>53</td></tr> <tr><td>52</td><td>51</td><td></td><td>48</td><td>47</td><td>46</td><td>44</td><td>42</td><td></td><td>40</td><td>39</td><td></td><td></td><td>34</td><td>33</td></tr> <tr><td>73</td><td></td><td></td><td>32</td><td></td><td>30</td><td></td><td></td><td>26</td><td>25</td><td></td><td>22</td><td>21</td><td></td><td></td></tr> <tr><td></td><td></td><td></td><td>15</td><td>14</td><td></td><td></td><td></td><td>10</td><td>9</td><td></td><td>6</td><td>5</td><td>4</td><td></td><td></td></tr> </table>	72	70		68	67	66		63	62		59	57		53	52	51		48	47	46	44	42		40	39			34	33	73			32		30			26	25		22	21						15	14				10	9		6	5	4									
72	70		68	67	66		63	62		59	57		53																																																													
52	51		48	47	46	44	42		40	39			34	33																																																												
73			32		30			26	25		22	21																																																														
			15	14				10	9		6	5	4																																																													
AVAILABLE	NOT APPLICABLE	34566-3413	G	0	A	BLACK	<table border="1"> <tr><td>72</td><td>70</td><td></td><td>67</td><td>66</td><td>65</td><td></td><td></td><td>61</td><td></td><td>58</td><td>57</td><td>55</td><td>54</td></tr> <tr><td></td><td>50</td><td>49</td><td>47</td><td>45</td><td>44</td><td>43</td><td>42</td><td>41</td><td>39</td><td></td><td>37</td><td>35</td><td></td></tr> <tr><td>73</td><td></td><td></td><td>32</td><td>30</td><td></td><td></td><td>27</td><td>26</td><td>25</td><td>24</td><td></td><td>21</td><td>20</td><td>19</td><td>18</td><td>17</td></tr> <tr><td></td><td></td><td></td><td>16</td><td>15</td><td>13</td><td></td><td>11</td><td>10</td><td>9</td><td>8</td><td></td><td>6</td><td>5</td><td>3</td><td>2</td><td>1</td></tr> </table>	72	70		67	66	65			61		58	57	55	54		50	49	47	45	44	43	42	41	39		37	35		73			32	30			27	26	25	24		21	20	19	18	17				16	15	13		11	10	9	8		6	5	3	2	1					
72	70		67	66	65			61		58	57	55	54																																																													
	50	49	47	45	44	43	42	41	39		37	35																																																														
73			32	30			27	26	25	24		21	20	19	18	17																																																										
			16	15	13		11	10	9	8		6	5	3	2	1																																																										
AVAILABLE	NOT APPLICABLE	34566-3423	G	9	C	BLUE	<table border="1"> <tr><td></td><td></td><td>69</td><td></td><td></td><td></td><td>63</td><td></td><td></td><td></td><td>58</td><td>56</td><td>55</td><td>54</td><td>53</td></tr> <tr><td>52</td><td>51</td><td>49</td><td></td><td></td><td></td><td>44</td><td>43</td><td>42</td><td>41</td><td></td><td></td><td>36</td><td>35</td><td>34</td><td>33</td></tr> <tr><td>73</td><td></td><td></td><td></td><td></td><td></td><td>28</td><td>26</td><td></td><td></td><td></td><td></td><td></td><td>19</td><td>18</td><td>17</td></tr> <tr><td></td><td></td><td></td><td></td><td></td><td></td><td>12</td><td>10</td><td></td><td></td><td></td><td></td><td></td><td></td><td>3</td><td>2</td><td>1</td></tr> </table>			69				63				58	56	55	54	53	52	51	49				44	43	42	41			36	35	34	33	73						28	26						19	18	17							12	10							3	2	1			
		69				63				58	56	55	54	53																																																												
52	51	49				44	43	42	41			36	35	34	33																																																											
73						28	26						19	18	17																																																											
						12	10							3	2	1																																																										

ENTER DESCRIPTION IEC NO: UAU2014-0376 DRAWN BY: CHKD APPR: WOSHY 2013/09/05 2013/09/06 05	QUALITY SYMBOLS ∇=0 ∇=0 ∇=0	GENERAL TOLERANCES (UNLESS SPECIFIED) mm INCH 4 PLACES ± --- ± --- 3 PLACES ± --- ± --- 2 PLACES ± --- ± --- 1 PLACE ± --- ± --- 0 PLACE ± --- ± --- ANGULAR ± --- ° DRAFT WHERE APPLICABLE MUST REMAIN WITHIN DIMENSIONS	DIMENSION STYLE MM ONLY	SCALE DESIGN UNITS METRIC	THIRD ANGLE PROJECTION	
	DRAWN BY: SKRAJENDRANA DATE: 2011/02/14	CHECKED BY: MVANSLAMBROU DATE: 2011/02/14	APPROVED BY:	MATERIAL NO. SEE BOM TABLE	DOCUMENT NO. SD-34566-001	SHEET NO. 40 OF 68
	MX123 66/73/80CKT HRNS CONN ASSY 					
	THIS DRAWING CONTAINS INFORMATION THAT IS PROPRIETARY TO MOLEX INCORPORATED AND SHOULD NOT BE USED WITHOUT WRITTEN PERMISSION					

STATUS	GM PART #	MATERIAL #	PART/MATERIAL REVISION	WIRE DRESS OPTION	KEY OPTION	COLOR (TPA)	NUMBERS INDICATE CAVITIES OPEN FOR CIRCUITS																																																																												
AVAILABLE	NOT APPLICABLE	34566-3433	G	9	C	BLUE	<table border="1"> <tr><td>72</td><td>70</td><td></td><td></td><td>66</td><td></td><td>63</td><td>62</td><td></td><td></td><td>59</td><td></td><td>57</td><td>56</td><td>55</td><td>53</td></tr> <tr><td>52</td><td>51</td><td></td><td></td><td>46</td><td>44</td><td>42</td><td>40</td><td>39</td><td></td><td>22</td><td>21</td><td></td><td></td><td>34</td><td>33</td></tr> <tr><td></td><td></td><td>73</td><td></td><td>30</td><td></td><td>26</td><td>25</td><td></td><td></td><td>6</td><td></td><td></td><td></td><td></td><td></td></tr> <tr><td></td><td></td><td></td><td></td><td>15</td><td>14</td><td></td><td>10</td><td>9</td><td></td><td></td><td></td><td></td><td></td><td></td><td></td></tr> </table>	72	70			66		63	62			59		57	56	55	53	52	51			46	44	42	40	39		22	21			34	33			73		30		26	25			6										15	14		10	9																			
72	70			66		63	62			59		57	56	55	53																																																																				
52	51			46	44	42	40	39		22	21			34	33																																																																				
		73		30		26	25			6																																																																									
				15	14		10	9																																																																											
AVAILABLE	NOT APPLICABLE	34566-3443	G	0	A	BLACK	<table border="1"> <tr><td></td><td>71</td><td>69</td><td></td><td></td><td>65</td><td>64</td><td>63</td><td></td><td>60</td><td></td><td></td><td>57</td><td>56</td><td>55</td><td>54</td><td>53</td></tr> <tr><td>52</td><td>51</td><td>49</td><td></td><td></td><td>45</td><td>44</td><td>43</td><td>42</td><td>41</td><td></td><td></td><td>37</td><td>36</td><td>35</td><td>34</td><td>33</td></tr> <tr><td></td><td></td><td></td><td>73</td><td>32</td><td>30</td><td>28</td><td>26</td><td></td><td></td><td>23</td><td></td><td></td><td></td><td>19</td><td>18</td><td></td></tr> <tr><td></td><td></td><td></td><td></td><td>16</td><td></td><td>12</td><td>10</td><td></td><td></td><td></td><td></td><td></td><td></td><td>3</td><td></td><td></td></tr> </table>		71	69			65	64	63		60			57	56	55	54	53	52	51	49			45	44	43	42	41			37	36	35	34	33				73	32	30	28	26			23				19	18						16		12	10							3										
	71	69			65	64	63		60			57	56	55	54	53																																																																			
52	51	49			45	44	43	42	41			37	36	35	34	33																																																																			
			73	32	30	28	26			23				19	18																																																																				
				16		12	10							3																																																																					
AVAILABLE	NOT APPLICABLE	34566-3453	G	0	A	BLACK	<table border="1"> <tr><td></td><td></td><td></td><td></td><td></td><td></td><td></td><td></td><td></td><td></td><td>61</td><td></td><td></td><td></td><td></td><td></td><td></td></tr> <tr><td></td><td></td><td></td><td></td><td></td><td></td><td></td><td></td><td></td><td></td><td></td><td></td><td></td><td></td><td></td><td>20</td><td></td></tr> <tr><td></td><td></td><td></td><td>73</td><td></td><td></td><td></td><td></td><td></td><td></td><td>9</td><td></td><td></td><td>5</td><td></td><td></td><td>1</td></tr> </table>											61																						20					73							9			5			1																									
										61																																																																									
															20																																																																				
			73							9			5			1																																																																			
AVAILABLE	NOT APPLICABLE	34566-3463	G	9	H	ST GRY	<table border="1"> <tr><td></td><td></td><td></td><td></td><td></td><td></td><td></td><td></td><td></td><td></td><td></td><td></td><td></td><td></td><td></td><td></td><td>61</td></tr> <tr><td></td><td></td><td></td><td></td><td></td><td></td><td></td><td></td><td></td><td></td><td></td><td></td><td></td><td></td><td></td><td></td><td></td></tr> <tr><td>20</td><td></td><td></td><td></td><td></td><td></td><td></td><td></td><td></td><td></td><td>9</td><td></td><td></td><td>5</td><td></td><td></td><td>1</td></tr> </table>																	61																		20										9			5			1																									
																61																																																																			
20										9			5			1																																																																			
AVAILABLE	NOT APPLICABLE	34566-3473	G	9	B	ST GRY	<table border="1"> <tr><td>72</td><td>71</td><td>69</td><td>68</td><td>67</td><td>66</td><td>65</td><td>64</td><td></td><td>62</td><td>61</td><td>60</td><td>59</td><td>58</td><td>57</td><td>56</td><td>55</td><td>54</td></tr> <tr><td>52</td><td>51</td><td>50</td><td>49</td><td></td><td>46</td><td>44</td><td></td><td></td><td></td><td></td><td>40</td><td>38</td><td>37</td><td>36</td><td></td><td></td><td></td></tr> <tr><td></td><td></td><td></td><td></td><td>73</td><td>32</td><td>31</td><td>30</td><td>29</td><td>28</td><td>27</td><td>25</td><td>24</td><td></td><td>21</td><td>20</td><td>18</td><td>17</td></tr> <tr><td></td><td></td><td></td><td></td><td></td><td>16</td><td>15</td><td>14</td><td>13</td><td>12</td><td>10</td><td>9</td><td>7</td><td>6</td><td>5</td><td>4</td><td>3</td><td>2</td></tr> </table>	72	71	69	68	67	66	65	64		62	61	60	59	58	57	56	55	54	52	51	50	49		46	44					40	38	37	36								73	32	31	30	29	28	27	25	24		21	20	18	17						16	15	14	13	12	10	9	7	6	5	4	3	2				
72	71	69	68	67	66	65	64		62	61	60	59	58	57	56	55	54																																																																		
52	51	50	49		46	44					40	38	37	36																																																																					
				73	32	31	30	29	28	27	25	24		21	20	18	17																																																																		
					16	15	14	13	12	10	9	7	6	5	4	3	2																																																																		
AVAILABLE	NOT APPLICABLE	34566-3483	G	0	B	ST GRY	<table border="1"> <tr><td>72</td><td>71</td><td>70</td><td>69</td><td>68</td><td>67</td><td>66</td><td>65</td><td></td><td></td><td>61</td><td>60</td><td></td><td></td><td>57</td><td>56</td><td>55</td><td>54</td></tr> <tr><td>52</td><td>51</td><td>50</td><td>49</td><td>48</td><td>46</td><td>44</td><td></td><td></td><td></td><td></td><td>40</td><td>38</td><td>37</td><td>36</td><td></td><td></td><td></td></tr> <tr><td></td><td></td><td></td><td></td><td></td><td></td><td></td><td></td><td></td><td></td><td></td><td>24</td><td></td><td></td><td>21</td><td>20</td><td>19</td><td>18</td><td>17</td></tr> <tr><td></td><td></td><td></td><td></td><td></td><td></td><td></td><td></td><td></td><td></td><td></td><td></td><td>7</td><td>6</td><td>5</td><td>4</td><td>2</td><td></td><td></td></tr> </table>	72	71	70	69	68	67	66	65			61	60			57	56	55	54	52	51	50	49	48	46	44					40	38	37	36															24			21	20	19	18	17													7	6	5	4	2				
72	71	70	69	68	67	66	65			61	60			57	56	55	54																																																																		
52	51	50	49	48	46	44					40	38	37	36																																																																					
											24			21	20	19	18	17																																																																	
												7	6	5	4	2																																																																			
AVAILABLE	NOT APPLICABLE	34566-3493	G	0	A	BLACK	<table border="1"> <tr><td>72</td><td>70</td><td></td><td></td><td>67</td><td>66</td><td>65</td><td></td><td></td><td></td><td>61</td><td></td><td></td><td>58</td><td>57</td><td></td><td>55</td><td>54</td></tr> <tr><td></td><td></td><td>49</td><td></td><td>47</td><td>45</td><td>44</td><td>43</td><td>42</td><td>41</td><td></td><td>39</td><td></td><td>37</td><td></td><td>35</td><td></td><td></td></tr> <tr><td></td><td></td><td></td><td>73</td><td>32</td><td>30</td><td></td><td>27</td><td>26</td><td>25</td><td>24</td><td></td><td></td><td>21</td><td>20</td><td>19</td><td>18</td><td>17</td></tr> <tr><td></td><td></td><td></td><td></td><td>16</td><td>15</td><td>13</td><td></td><td>11</td><td>10</td><td>9</td><td>8</td><td></td><td>6</td><td>5</td><td>3</td><td>2</td><td>1</td></tr> </table>	72	70			67	66	65				61			58	57		55	54			49		47	45	44	43	42	41		39		37		35						73	32	30		27	26	25	24			21	20	19	18	17					16	15	13		11	10	9	8		6	5	3	2	1				
72	70			67	66	65				61			58	57		55	54																																																																		
		49		47	45	44	43	42	41		39		37		35																																																																				
			73	32	30		27	26	25	24			21	20	19	18	17																																																																		
				16	15	13		11	10	9	8		6	5	3	2	1																																																																		
AVAILABLE	NOT APPLICABLE	34566-3513	G	0	A	BLACK	<table border="1"> <tr><td></td><td>70</td><td>69</td><td></td><td></td><td></td><td></td><td>63</td><td>62</td><td>61</td><td>60</td><td></td><td></td><td>58</td><td>57</td><td>56</td><td>55</td><td>54</td><td>53</td></tr> <tr><td>52</td><td>51</td><td>49</td><td></td><td></td><td></td><td></td><td>44</td><td>43</td><td>42</td><td>41</td><td></td><td></td><td></td><td>37</td><td>36</td><td>34</td><td></td><td></td></tr> <tr><td></td><td></td><td></td><td></td><td></td><td></td><td></td><td></td><td>29</td><td>28</td><td>27</td><td>26</td><td></td><td></td><td></td><td></td><td>19</td><td>18</td><td></td></tr> <tr><td></td><td></td><td></td><td>73</td><td></td><td></td><td></td><td>16</td><td>15</td><td>13</td><td>12</td><td>11</td><td>10</td><td></td><td></td><td></td><td>3</td><td></td><td></td></tr> </table>		70	69					63	62	61	60			58	57	56	55	54	53	52	51	49					44	43	42	41				37	36	34											29	28	27	26					19	18					73				16	15	13	12	11	10				3		
	70	69					63	62	61	60			58	57	56	55	54	53																																																																	
52	51	49					44	43	42	41				37	36	34																																																																			
								29	28	27	26					19	18																																																																		
			73				16	15	13	12	11	10				3																																																																			

ENTER DESCRIPTION IEC NO: UAU2014-0376 DRAWN BY: 2013/09/05 CHKD: 2013/09/06 APPR: IKOSHY REV: 05	QUALITY SYMBOLS	GENERAL TOLERANCES (UNLESS SPECIFIED)	DIMENSION STYLE	SCALE	DESIGN UNITS	THIRD ANGLE PROJECTION
	∇=0 ∇=0 ∇=0	mm INCH 4 PLACES #--- #--- 3 PLACES #--- #--- 2 PLACES #--- #--- 1 PLACE #--- #--- 0 PLACE #--- #---	MM ONLY		METRIC	
	ANGULAR ±---° DRAFT WHERE APPLICABLE MUST REMAIN WITHIN DIMENSIONS	DRAWN BY: SKRAJENDRANA 2011/02/14 CHECKED BY: MVANSLAMBROU 2011/02/14 APPROVED BY:	DATE: 2011/02/14 DATE: 2011/02/14 DATE:	TITLE: MX123 66/73/80CKT HRNS CONN ASSY molex		
	SEE BOM TABLE	MATERIAL NO. SD-34566-001 DOCUMENT NO. 41 OF 68	THIS DRAWING CONTAINS INFORMATION THAT IS PROPRIETARY TO MOLEX INCORPORATED AND SHOULD NOT BE USED WITHOUT WRITTEN PERMISSION			

STATUS	GM PART #	MATERIAL #	PART/MATERIAL REVISION	WIRE DRESS OPTION	KEY OPTION	COLOR (TPA)	NUMBERS INDICATE CAVITIES OPEN FOR CIRCUITS																																																																																															
AVAILABLE	NOT APPLICABLE	34566-3823	G	0	A	BLACK	<table border="1"> <tr><td></td><td>70</td><td>69</td><td></td><td></td><td></td><td>63</td><td>61</td><td></td><td></td><td>58</td><td>57</td><td>56</td><td>55</td><td>54</td><td>53</td></tr> <tr><td>52</td><td>51</td><td>49</td><td></td><td></td><td></td><td>44</td><td>43</td><td>41</td><td></td><td></td><td></td><td>37</td><td>36</td><td></td><td>34</td></tr> <tr><td></td><td></td><td></td><td>73</td><td>32</td><td></td><td></td><td>27</td><td>26</td><td></td><td></td><td></td><td></td><td></td><td>19</td><td>18</td></tr> <tr><td></td><td></td><td></td><td></td><td>16</td><td>15</td><td></td><td></td><td>11</td><td>10</td><td></td><td></td><td></td><td></td><td></td><td>3</td></tr> </table>		70	69				63	61			58	57	56	55	54	53	52	51	49				44	43	41				37	36		34				73	32			27	26						19	18					16	15			11	10						3																															
	70	69				63	61			58	57	56	55	54	53																																																																																							
52	51	49				44	43	41				37	36		34																																																																																							
			73	32			27	26						19	18																																																																																							
				16	15			11	10						3																																																																																							
AVAILABLE	NOT APPLICABLE	34566-3833	G	0	A	BLACK	<table border="1"> <tr><td></td><td>70</td><td>69</td><td></td><td></td><td></td><td>63</td><td>62</td><td>61</td><td></td><td></td><td></td><td>57</td><td>56</td><td>55</td><td>54</td><td>53</td></tr> <tr><td>52</td><td>51</td><td>49</td><td></td><td></td><td></td><td>44</td><td>43</td><td>42</td><td>41</td><td></td><td></td><td></td><td>37</td><td>36</td><td></td><td>34</td></tr> <tr><td></td><td></td><td></td><td>73</td><td>32</td><td></td><td>29</td><td>28</td><td>27</td><td>26</td><td></td><td></td><td>23</td><td></td><td></td><td>19</td><td>18</td></tr> <tr><td></td><td></td><td></td><td></td><td>16</td><td>15</td><td>13</td><td>12</td><td>11</td><td>10</td><td></td><td>8</td><td></td><td></td><td></td><td>3</td><td></td></tr> </table>		70	69				63	62	61				57	56	55	54	53	52	51	49				44	43	42	41				37	36		34				73	32		29	28	27	26			23			19	18					16	15	13	12	11	10		8				3																												
	70	69				63	62	61				57	56	55	54	53																																																																																						
52	51	49				44	43	42	41				37	36		34																																																																																						
			73	32		29	28	27	26			23			19	18																																																																																						
				16	15	13	12	11	10		8				3																																																																																							
AVAILABLE	NOT APPLICABLE	34566-3843	G	0	A	BLACK	<table border="1"> <tr><td>72</td><td>71</td><td>70</td><td>69</td><td>68</td><td>67</td><td>66</td><td></td><td>64</td><td>63</td><td>62</td><td></td><td>60</td><td>59</td><td></td><td></td><td>55</td><td>54</td><td>53</td></tr> <tr><td>52</td><td></td><td></td><td>49</td><td>48</td><td></td><td></td><td></td><td>44</td><td>43</td><td>42</td><td>41</td><td>40</td><td>39</td><td></td><td></td><td></td><td>35</td><td>34</td><td>33</td></tr> <tr><td></td><td></td><td></td><td></td><td></td><td></td><td></td><td>73</td><td>32</td><td></td><td>29</td><td>28</td><td>27</td><td>25</td><td>24</td><td>23</td><td></td><td></td><td>19</td><td>18</td><td>17</td></tr> <tr><td></td><td></td><td></td><td></td><td></td><td></td><td></td><td></td><td>16</td><td></td><td>13</td><td>12</td><td>11</td><td></td><td>9</td><td>8</td><td>7</td><td>6</td><td>5</td><td>4</td><td>3</td><td>2</td><td>1</td></tr> </table>	72	71	70	69	68	67	66		64	63	62		60	59			55	54	53	52			49	48				44	43	42	41	40	39				35	34	33								73	32		29	28	27	25	24	23			19	18	17									16		13	12	11		9	8	7	6	5	4	3	2	1												
72	71	70	69	68	67	66		64	63	62		60	59			55	54	53																																																																																				
52			49	48				44	43	42	41	40	39				35	34	33																																																																																			
							73	32		29	28	27	25	24	23			19	18	17																																																																																		
								16		13	12	11		9	8	7	6	5	4	3	2	1																																																																																
AVAILABLE	NOT APPLICABLE	34566-3853	G	0	A	BLACK	<table border="1"> <tr><td>72</td><td>71</td><td>70</td><td>69</td><td>68</td><td>67</td><td>66</td><td>65</td><td>64</td><td>63</td><td>62</td><td></td><td>60</td><td>59</td><td></td><td></td><td>55</td><td>54</td><td>53</td></tr> <tr><td>52</td><td></td><td></td><td>49</td><td>48</td><td></td><td></td><td></td><td>45</td><td>44</td><td>43</td><td>42</td><td>41</td><td>40</td><td>39</td><td></td><td></td><td>35</td><td>34</td><td>33</td></tr> <tr><td></td><td></td><td></td><td></td><td></td><td></td><td></td><td></td><td></td><td></td><td></td><td></td><td></td><td></td><td></td><td></td><td></td><td></td><td>19</td><td>18</td><td>17</td></tr> <tr><td></td><td></td><td></td><td></td><td></td><td></td><td></td><td></td><td></td><td></td><td></td><td></td><td></td><td></td><td></td><td></td><td></td><td></td><td></td><td></td><td></td><td></td><td>1</td></tr> </table>	72	71	70	69	68	67	66	65	64	63	62		60	59			55	54	53	52			49	48				45	44	43	42	41	40	39			35	34	33																			19	18	17																							1												
72	71	70	69	68	67	66	65	64	63	62		60	59			55	54	53																																																																																				
52			49	48				45	44	43	42	41	40	39			35	34	33																																																																																			
																		19	18	17																																																																																		
																						1																																																																																
AVAILABLE	NOT APPLICABLE	34566-3863	G	0	B	ST GRAY	<table border="1"> <tr><td>72</td><td>71</td><td>70</td><td></td><td>68</td><td>67</td><td>66</td><td></td><td></td><td></td><td>62</td><td>61</td><td>60</td><td>59</td><td>58</td><td>57</td><td>56</td><td>55</td><td>54</td><td>53</td></tr> <tr><td>52</td><td>51</td><td>50</td><td></td><td>48</td><td>47</td><td>46</td><td></td><td></td><td></td><td>42</td><td>41</td><td>40</td><td>39</td><td>38</td><td>37</td><td>36</td><td>35</td><td>34</td><td>33</td></tr> <tr><td></td><td></td><td></td><td></td><td></td><td></td><td></td><td></td><td></td><td></td><td></td><td></td><td></td><td></td><td></td><td></td><td></td><td></td><td></td><td>17</td></tr> <tr><td></td><td></td><td></td><td></td><td></td><td></td><td></td><td></td><td></td><td></td><td></td><td></td><td></td><td></td><td></td><td></td><td></td><td></td><td></td><td></td><td></td><td></td><td>1</td></tr> </table>	72	71	70		68	67	66				62	61	60	59	58	57	56	55	54	53	52	51	50		48	47	46				42	41	40	39	38	37	36	35	34	33																				17																							1												
72	71	70		68	67	66				62	61	60	59	58	57	56	55	54	53																																																																																			
52	51	50		48	47	46				42	41	40	39	38	37	36	35	34	33																																																																																			
																			17																																																																																			
																						1																																																																																
AVAILABLE	NOT APPLICABLE	34566-3873	G	0	B	ST GRAY	<table border="1"> <tr><td></td><td></td><td></td><td></td><td></td><td></td><td></td><td></td><td></td><td>63</td><td></td><td></td><td></td><td>59</td><td>58</td><td>57</td><td>56</td><td>55</td><td></td><td></td><td></td><td></td><td></td></tr> <tr><td></td><td></td><td></td><td></td><td></td><td></td><td></td><td></td><td></td><td></td><td></td><td></td><td></td><td>39</td><td>38</td><td>37</td><td>36</td><td>35</td><td>34</td><td></td><td></td><td></td><td></td></tr> <tr><td></td><td></td><td></td><td></td><td></td><td></td><td></td><td></td><td></td><td></td><td></td><td></td><td></td><td></td><td></td><td></td><td></td><td></td><td></td><td></td><td></td><td></td><td></td></tr> <tr><td></td><td></td><td></td><td></td><td></td><td></td><td></td><td></td><td></td><td></td><td></td><td></td><td></td><td></td><td></td><td></td><td></td><td></td><td></td><td></td><td></td><td></td><td></td></tr> </table>										63				59	58	57	56	55																			39	38	37	36	35	34																																																					
									63				59	58	57	56	55																																																																																					
													39	38	37	36	35	34																																																																																				
AVAILABLE	NOT APPLICABLE	34566-3883	G	0	B	ST GRAY	<table border="1"> <tr><td></td><td></td><td></td><td></td><td></td><td></td><td>67</td><td>66</td><td></td><td></td><td></td><td></td><td></td><td>59</td><td>58</td><td>57</td><td>56</td><td>55</td><td></td><td></td><td></td><td></td><td>53</td></tr> <tr><td></td><td></td><td></td><td></td><td></td><td></td><td></td><td></td><td></td><td></td><td></td><td></td><td></td><td>39</td><td>38</td><td>37</td><td>36</td><td>35</td><td>34</td><td></td><td></td><td></td><td>33</td></tr> <tr><td></td><td></td><td></td><td></td><td></td><td></td><td></td><td></td><td></td><td></td><td></td><td></td><td></td><td></td><td></td><td></td><td></td><td></td><td></td><td></td><td></td><td></td><td></td></tr> <tr><td></td><td></td><td></td><td></td><td></td><td></td><td></td><td></td><td></td><td></td><td></td><td></td><td></td><td></td><td></td><td></td><td></td><td></td><td></td><td></td><td></td><td></td><td></td></tr> </table>							67	66						59	58	57	56	55					53														39	38	37	36	35	34				33																																																	
						67	66						59	58	57	56	55					53																																																																																
													39	38	37	36	35	34				33																																																																																
AVAILABLE	NOT APPLICABLE	34566-3893	G	0	C	BLUE	<table border="1"> <tr><td>72</td><td>70</td><td></td><td>68</td><td>67</td><td>66</td><td></td><td></td><td></td><td>63</td><td>62</td><td></td><td></td><td>59</td><td></td><td>57</td><td></td><td></td><td></td><td></td><td></td><td></td><td>53</td></tr> <tr><td>52</td><td>51</td><td></td><td>48</td><td>47</td><td>46</td><td></td><td></td><td></td><td>44</td><td>42</td><td></td><td></td><td></td><td></td><td></td><td></td><td></td><td></td><td></td><td></td><td></td><td>34</td><td>33</td></tr> <tr><td></td><td></td><td></td><td></td><td></td><td></td><td></td><td></td><td></td><td></td><td></td><td></td><td></td><td></td><td></td><td></td><td></td><td></td><td></td><td></td><td></td><td></td><td></td><td></td></tr> <tr><td></td><td></td><td></td><td></td><td></td><td></td><td></td><td></td><td></td><td></td><td></td><td></td><td></td><td></td><td></td><td></td><td></td><td></td><td></td><td></td><td></td><td></td><td></td><td></td></tr> </table>	72	70		68	67	66				63	62			59		57							53	52	51		48	47	46				44	42												34	33																																																
72	70		68	67	66				63	62			59		57							53																																																																																
52	51		48	47	46				44	42												34	33																																																																															

ENTER DESCRIPTION IEC NO: UAU2014-0376 DRAWN BY: 2013/09/05 CHKD: 2013/09/06 APPR: IKOSHY REV: 05	QUALITY SYMBOLS ∇=0 ∇=0 ∇=0	GENERAL TOLERANCES (UNLESS SPECIFIED): mm INCH 4 PLACES ±--- ±--- 3 PLACES ±--- ±--- 2 PLACES ±--- ±--- 1 PLACE ±--- ±--- 0 PLACE ±--- ±---	DIMENSION STYLE MM ONLY	SCALE DESIGN UNITS METRIC	THIRD ANGLE PROJECTION	
	DRAWN BY: SKRAJENDRANA DATE: 2011/02/14	CHECKED BY: MYANSLAMBROU DATE: 2011/02/14	APPROVED BY:	MATERIAL NO. SEE BOM TABLE	DOCUMENT NO. SD-34566-001	SHEET NO. 45 OF 68
	TITLE: MX123 66/73/80CKT HRNS CONN ASSY					
	THIS DRAWING CONTAINS INFORMATION THAT IS PROPRIETARY TO MOLEX INCORPORATED AND SHOULD NOT BE USED WITHOUT WRITTEN PERMISSION					

STATUS	GM PART #	MATERIAL #	PART/MATERIAL REVISION	WIRE DRESS OPTION	KEY OPTION	COLOR (TPA)	NUMBERS INDICATE CAVITIES OPEN FOR CIRCUITS																																																																																					
AVAILABLE	NOT APPLICABLE	34566-3913	G	0	A	BLACK	<table border="1"> <tr><td>71</td><td>70</td><td>69</td><td></td><td></td><td></td><td>64</td><td>63</td><td></td><td>60</td><td>58</td><td>57</td><td>56</td><td>55</td><td>54</td><td>53</td></tr> <tr><td>52</td><td>51</td><td>49</td><td></td><td></td><td></td><td>45</td><td>44</td><td>43</td><td>42</td><td>41</td><td></td><td></td><td>37</td><td>36</td><td>34</td></tr> <tr><td></td><td></td><td></td><td>32</td><td>30</td><td></td><td>28</td><td>26</td><td></td><td></td><td>23</td><td></td><td></td><td>21</td><td>19</td><td>18</td></tr> <tr><td></td><td></td><td></td><td>16</td><td>15</td><td></td><td>12</td><td>10</td><td></td><td></td><td>8</td><td></td><td></td><td>5</td><td>3</td><td></td></tr> <tr><td></td><td></td><td></td><td></td><td></td><td></td><td></td><td></td><td></td><td></td><td></td><td></td><td></td><td></td><td></td><td></td></tr> </table>	71	70	69				64	63		60	58	57	56	55	54	53	52	51	49				45	44	43	42	41			37	36	34				32	30		28	26			23			21	19	18				16	15		12	10			8			5	3																						
71	70	69				64	63		60	58	57	56	55	54	53																																																																													
52	51	49				45	44	43	42	41			37	36	34																																																																													
			32	30		28	26			23			21	19	18																																																																													
			16	15		12	10			8			5	3																																																																														
AVAILABLE	NOT APPLICABLE	34566-3923	G	0	B	ST GRAY	<table border="1"> <tr><td>72</td><td>70</td><td>68</td><td>66</td><td></td><td></td><td></td><td></td><td></td><td>60</td><td>59</td><td></td><td></td><td>55</td><td>54</td><td>53</td></tr> <tr><td>52</td><td>50</td><td>48</td><td>46</td><td></td><td></td><td></td><td></td><td></td><td>40</td><td>39</td><td></td><td></td><td>35</td><td>34</td><td>33</td></tr> <tr><td></td><td></td><td></td><td></td><td>32</td><td>31</td><td>30</td><td>29</td><td>28</td><td>27</td><td>26</td><td>25</td><td>24</td><td></td><td>19</td><td>18</td></tr> <tr><td></td><td></td><td></td><td></td><td>16</td><td></td><td></td><td></td><td></td><td>10</td><td>9</td><td>8</td><td>7</td><td></td><td></td><td></td></tr> <tr><td></td><td></td><td></td><td></td><td></td><td></td><td></td><td></td><td></td><td></td><td></td><td></td><td></td><td></td><td></td><td></td></tr> </table>	72	70	68	66						60	59			55	54	53	52	50	48	46						40	39			35	34	33					32	31	30	29	28	27	26	25	24		19	18					16					10	9	8	7																								
72	70	68	66						60	59			55	54	53																																																																													
52	50	48	46						40	39			35	34	33																																																																													
				32	31	30	29	28	27	26	25	24		19	18																																																																													
				16					10	9	8	7																																																																																
AVAILABLE	NOT APPLICABLE	34566-3933	G	0	A	BLACK	<table border="1"> <tr><td>71</td><td>70</td><td>69</td><td></td><td></td><td></td><td>64</td><td>63</td><td></td><td>60</td><td>58</td><td>57</td><td>56</td><td>55</td><td>54</td><td>53</td></tr> <tr><td>52</td><td>51</td><td>49</td><td></td><td></td><td></td><td>45</td><td>44</td><td>43</td><td>42</td><td>41</td><td></td><td></td><td></td><td></td><td>34</td></tr> <tr><td></td><td></td><td></td><td>32</td><td>30</td><td></td><td>28</td><td>26</td><td></td><td></td><td></td><td></td><td></td><td></td><td>19</td><td>18</td></tr> <tr><td></td><td></td><td></td><td>16</td><td>15</td><td></td><td>12</td><td>10</td><td></td><td></td><td></td><td></td><td></td><td></td><td>3</td><td></td></tr> <tr><td></td><td></td><td></td><td></td><td></td><td></td><td></td><td></td><td></td><td></td><td></td><td></td><td></td><td></td><td></td><td></td></tr> </table>	71	70	69				64	63		60	58	57	56	55	54	53	52	51	49				45	44	43	42	41					34				32	30		28	26							19	18				16	15		12	10							3																						
71	70	69				64	63		60	58	57	56	55	54	53																																																																													
52	51	49				45	44	43	42	41					34																																																																													
			32	30		28	26							19	18																																																																													
			16	15		12	10							3																																																																														
AVAILABLE	NOT APPLICABLE	34566-3943	G	0	C	BLUE	<table border="1"> <tr><td>72</td><td>70</td><td>68</td><td>66</td><td></td><td></td><td></td><td></td><td></td><td>60</td><td>59</td><td></td><td></td><td>55</td><td>54</td><td>53</td></tr> <tr><td>52</td><td>50</td><td>48</td><td>46</td><td></td><td></td><td></td><td></td><td></td><td>40</td><td>39</td><td></td><td></td><td>35</td><td>34</td><td>33</td></tr> <tr><td></td><td></td><td></td><td></td><td>32</td><td>31</td><td>30</td><td>29</td><td>28</td><td>27</td><td>26</td><td>25</td><td>24</td><td></td><td></td><td></td></tr> <tr><td></td><td></td><td></td><td></td><td>16</td><td></td><td></td><td></td><td></td><td>10</td><td>9</td><td>8</td><td></td><td></td><td></td><td></td></tr> <tr><td></td><td></td><td></td><td></td><td></td><td></td><td></td><td></td><td></td><td></td><td></td><td></td><td></td><td></td><td></td><td></td></tr> </table>	72	70	68	66						60	59			55	54	53	52	50	48	46						40	39			35	34	33					32	31	30	29	28	27	26	25	24								16					10	9	8																									
72	70	68	66						60	59			55	54	53																																																																													
52	50	48	46						40	39			35	34	33																																																																													
				32	31	30	29	28	27	26	25	24																																																																																
				16					10	9	8																																																																																	
AVAILABLE	NOT APPLICABLE	34566-3953	G	0	C	BLUE	<table border="1"> <tr><td>72</td><td>70</td><td>68</td><td></td><td></td><td></td><td>63</td><td>62</td><td></td><td>59</td><td>57</td><td></td><td></td><td></td><td></td><td>53</td></tr> <tr><td>52</td><td>51</td><td></td><td>48</td><td>47</td><td>46</td><td>44</td><td>42</td><td>40</td><td>39</td><td></td><td></td><td></td><td></td><td></td><td>34</td></tr> <tr><td></td><td></td><td></td><td>32</td><td>30</td><td></td><td></td><td>26</td><td>25</td><td></td><td>23</td><td>22</td><td>21</td><td>20</td><td></td><td></td></tr> <tr><td></td><td></td><td></td><td></td><td>15</td><td>14</td><td>13</td><td></td><td></td><td></td><td>7</td><td>6</td><td>5</td><td>4</td><td></td><td></td></tr> <tr><td></td><td></td><td></td><td></td><td></td><td></td><td></td><td></td><td></td><td></td><td></td><td></td><td></td><td></td><td></td><td></td></tr> </table>	72	70	68				63	62		59	57					53	52	51		48	47	46	44	42	40	39						34				32	30			26	25		23	22	21	20							15	14	13				7	6	5	4																							
72	70	68				63	62		59	57					53																																																																													
52	51		48	47	46	44	42	40	39						34																																																																													
			32	30			26	25		23	22	21	20																																																																															
				15	14	13				7	6	5	4																																																																															
AVAILABLE	NOT APPLICABLE	34566-3963	G	0	C	BLUE	<table border="1"> <tr><td>72</td><td>70</td><td>68</td><td>67</td><td>66</td><td></td><td>63</td><td>62</td><td></td><td>59</td><td>57</td><td></td><td></td><td></td><td></td><td>53</td></tr> <tr><td>52</td><td>51</td><td></td><td>48</td><td>47</td><td>46</td><td>44</td><td>42</td><td>40</td><td>39</td><td>38</td><td></td><td></td><td></td><td></td><td>34</td></tr> <tr><td></td><td></td><td></td><td>32</td><td>30</td><td></td><td></td><td>26</td><td>25</td><td></td><td></td><td>22</td><td>21</td><td></td><td></td><td></td></tr> <tr><td></td><td></td><td></td><td></td><td>15</td><td>14</td><td></td><td></td><td>10</td><td>9</td><td></td><td>6</td><td>5</td><td>4</td><td></td><td></td></tr> <tr><td></td><td></td><td></td><td></td><td></td><td></td><td></td><td></td><td></td><td></td><td></td><td></td><td></td><td></td><td></td><td></td></tr> </table>	72	70	68	67	66		63	62		59	57					53	52	51		48	47	46	44	42	40	39	38					34				32	30			26	25			22	21								15	14			10	9		6	5	4																							
72	70	68	67	66		63	62		59	57					53																																																																													
52	51		48	47	46	44	42	40	39	38					34																																																																													
			32	30			26	25			22	21																																																																																
				15	14			10	9		6	5	4																																																																															
AVAILABLE	NOT APPLICABLE	34566-3973	G	0	C	BLUE	<table border="1"> <tr><td>72</td><td>70</td><td>68</td><td>67</td><td></td><td></td><td>63</td><td>62</td><td></td><td>59</td><td>57</td><td></td><td></td><td></td><td></td><td>53</td></tr> <tr><td>52</td><td>51</td><td></td><td>48</td><td>47</td><td>46</td><td>44</td><td>42</td><td>40</td><td>39</td><td>38</td><td></td><td></td><td></td><td></td><td>34</td></tr> <tr><td></td><td></td><td></td><td>32</td><td>30</td><td></td><td></td><td>26</td><td>25</td><td></td><td></td><td>22</td><td>21</td><td></td><td></td><td></td></tr> <tr><td></td><td></td><td></td><td></td><td>15</td><td>14</td><td></td><td></td><td></td><td></td><td></td><td>6</td><td>5</td><td>4</td><td></td><td></td></tr> <tr><td></td><td></td><td></td><td></td><td></td><td></td><td></td><td></td><td></td><td></td><td></td><td></td><td></td><td></td><td></td><td></td></tr> </table>	72	70	68	67			63	62		59	57					53	52	51		48	47	46	44	42	40	39	38					34				32	30			26	25			22	21								15	14						6	5	4																							
72	70	68	67			63	62		59	57					53																																																																													
52	51		48	47	46	44	42	40	39	38					34																																																																													
			32	30			26	25			22	21																																																																																
				15	14						6	5	4																																																																															
AVAILABLE	NOT APPLICABLE	34566-3983	G	0	A	BLACK	<table border="1"> <tr><td>71</td><td>70</td><td>69</td><td></td><td></td><td></td><td>64</td><td>63</td><td></td><td>60</td><td>59</td><td>58</td><td>57</td><td>56</td><td>55</td><td>54</td><td>53</td></tr> <tr><td>52</td><td>51</td><td>49</td><td></td><td></td><td></td><td>45</td><td>44</td><td>43</td><td>42</td><td>41</td><td>40</td><td></td><td></td><td>37</td><td>36</td><td>34</td></tr> <tr><td></td><td></td><td></td><td>32</td><td>30</td><td></td><td>28</td><td>26</td><td></td><td></td><td></td><td></td><td></td><td></td><td>19</td><td>18</td><td></td></tr> <tr><td></td><td></td><td></td><td>16</td><td>15</td><td></td><td>12</td><td>10</td><td></td><td></td><td></td><td></td><td></td><td></td><td>3</td><td></td><td></td></tr> <tr><td></td><td></td><td></td><td></td><td></td><td></td><td></td><td></td><td></td><td></td><td></td><td></td><td></td><td></td><td></td><td></td><td></td></tr> </table>	71	70	69				64	63		60	59	58	57	56	55	54	53	52	51	49				45	44	43	42	41	40			37	36	34				32	30		28	26							19	18					16	15		12	10							3																			
71	70	69				64	63		60	59	58	57	56	55	54	53																																																																												
52	51	49				45	44	43	42	41	40			37	36	34																																																																												
			32	30		28	26							19	18																																																																													
			16	15		12	10							3																																																																														
AVAILABLE	NOT APPLICABLE	34566-3993	G	0	A	BLACK	<table border="1"> <tr><td></td><td>70</td><td>69</td><td></td><td></td><td></td><td>63</td><td>62</td><td>61</td><td>60</td><td>58</td><td>57</td><td>56</td><td>55</td><td>54</td><td>53</td></tr> <tr><td>52</td><td>51</td><td>49</td><td></td><td></td><td></td><td>44</td><td>43</td><td>42</td><td>41</td><td>40</td><td></td><td></td><td>37</td><td>36</td><td>34</td></tr> <tr><td></td><td></td><td></td><td>32</td><td></td><td></td><td>29</td><td>28</td><td>27</td><td>26</td><td></td><td></td><td></td><td></td><td>19</td><td>18</td></tr> <tr><td></td><td></td><td></td><td>16</td><td>15</td><td></td><td>13</td><td>12</td><td>11</td><td>10</td><td></td><td></td><td></td><td></td><td>3</td><td></td></tr> <tr><td></td><td></td><td></td><td></td><td></td><td></td><td></td><td></td><td></td><td></td><td></td><td></td><td></td><td></td><td></td><td></td></tr> </table>		70	69				63	62	61	60	58	57	56	55	54	53	52	51	49				44	43	42	41	40			37	36	34				32			29	28	27	26					19	18				16	15		13	12	11	10					3																						
	70	69				63	62	61	60	58	57	56	55	54	53																																																																													
52	51	49				44	43	42	41	40			37	36	34																																																																													
			32			29	28	27	26					19	18																																																																													
			16	15		13	12	11	10					3																																																																														

ENTER DESCRIPTION EC NO: VAAU2014-0376 DRAWN BY: CHKD CHKD: GS APPR: WOSHY 2013/09/05 2013/09/06 DESCRIPTION	QUALITY SYMBOLS	GENERAL TOLERANCES (UNLESS SPECIFIED)	DIMENSION STYLE	SCALE	DESIGN UNITS	THIRD ANGLE PROJECTION	
	∇=0 ∇=0 ∇=0	4 PLACES ±---- 3 PLACES ±---- 2 PLACES ±---- 1 PLACE ±---- 0 PLACE ±----	mm INCH ±---- ±---- ±---- ±---- ±---- ±---- ±---- ±----	MM ONLY DRAWN BY: SKRA JENDRANA 2011/02/14 CHECKED BY: MVANSLAMBROU 2011/02/14 APPROVED BY:	DATE: 2011/02/14 DATE: 2011/02/14 DATE:	METRIC MX123 66/73/80CKT HRNS CONN ASSY	M THIRD ANGLE PROJECTION
	ANGULAR ±---- DRAFT WHERE APPLICABLE MUST REMAIN WITHIN DIMENSIONS	SEE BOM TABLE	MATERIAL NO. SD-34566-001	DOCUMENT NO.	SHEET NO. 46 OF 68	THIS DRAWING CONTAINS INFORMATION THAT IS PROPRIETARY TO MOLEX INCORPORATED AND SHOULD NOT BE USED WITHOUT WRITTEN PERMISSION	

STATUS	GM PART #	MATERIAL #	PART/MATERIAL REVISION	WIRE DRESS OPTION	KEY OPTION	COLOR (TPA)	NUMBERS INDICATE CAVITIES OPEN FOR CIRCUITS																																																																															
AVAILABLE	NOT APPLICABLE	34566-4013	G	0	B	ST GRAY	<table border="1"> <tr><td>72</td><td>70</td><td>68</td><td>66</td><td></td><td></td><td></td><td></td><td>60</td><td>59</td><td></td><td></td><td>55</td><td>54</td><td>53</td></tr> <tr><td>52</td><td>50</td><td>48</td><td>46</td><td></td><td></td><td></td><td></td><td>40</td><td>39</td><td></td><td></td><td>35</td><td>34</td><td>33</td></tr> <tr><td colspan="2">73</td><td>32</td><td>31</td><td>30</td><td>29</td><td>28</td><td>27</td><td>26</td><td>25</td><td>24</td><td></td><td></td><td></td><td>17</td></tr> <tr><td colspan="2"></td><td>16</td><td></td><td></td><td></td><td></td><td></td><td>10</td><td>8</td><td></td><td></td><td></td><td></td><td>2</td><td>1</td></tr> </table>	72	70	68	66					60	59			55	54	53	52	50	48	46					40	39			35	34	33	73		32	31	30	29	28	27	26	25	24				17			16						10	8					2	1																		
72	70	68	66					60	59			55	54	53																																																																								
52	50	48	46					40	39			35	34	33																																																																								
73		32	31	30	29	28	27	26	25	24				17																																																																								
		16						10	8					2	1																																																																							
AVAILABLE	NOT APPLICABLE	34566-4023	G	0	B	ST GRAY	<table border="1"> <tr><td>72</td><td>71</td><td>70</td><td>68</td><td>67</td><td>66</td><td></td><td></td><td>62</td><td>61</td><td>60</td><td>59</td><td>58</td><td>57</td><td>56</td><td>55</td><td>54</td><td>53</td></tr> <tr><td>52</td><td>51</td><td>50</td><td>48</td><td>47</td><td>46</td><td></td><td></td><td>42</td><td>41</td><td>40</td><td>39</td><td>38</td><td>37</td><td>36</td><td>35</td><td>34</td><td>33</td></tr> <tr><td colspan="2">73</td><td>32</td><td>31</td><td>30</td><td>29</td><td>28</td><td>27</td><td>26</td><td>25</td><td>24</td><td></td><td></td><td></td><td></td><td></td><td></td><td></td></tr> <tr><td colspan="2"></td><td>16</td><td>15</td><td>14</td><td>13</td><td></td><td></td><td>10</td><td>9</td><td>8</td><td></td><td></td><td></td><td></td><td></td><td></td><td></td></tr> </table>	72	71	70	68	67	66			62	61	60	59	58	57	56	55	54	53	52	51	50	48	47	46			42	41	40	39	38	37	36	35	34	33	73		32	31	30	29	28	27	26	25	24										16	15	14	13			10	9	8														
72	71	70	68	67	66			62	61	60	59	58	57	56	55	54	53																																																																					
52	51	50	48	47	46			42	41	40	39	38	37	36	35	34	33																																																																					
73		32	31	30	29	28	27	26	25	24																																																																												
		16	15	14	13			10	9	8																																																																												
AVAILABLE	NOT APPLICABLE	34566-4033	G	0	C	BLUE	<table border="1"> <tr><td>72</td><td>70</td><td>68</td><td></td><td></td><td></td><td></td><td>63</td><td>62</td><td></td><td>59</td><td>58</td><td>57</td><td></td><td></td><td></td><td></td><td>53</td></tr> <tr><td>52</td><td>51</td><td></td><td>48</td><td>47</td><td></td><td>44</td><td>42</td><td>41</td><td>40</td><td>39</td><td>38</td><td></td><td></td><td></td><td></td><td></td><td>34</td><td>33</td></tr> <tr><td colspan="2">73</td><td></td><td>32</td><td></td><td>30</td><td></td><td></td><td>26</td><td>25</td><td></td><td></td><td>22</td><td>21</td><td>20</td><td></td><td></td><td></td><td>17</td></tr> <tr><td colspan="2"></td><td></td><td>15</td><td>14</td><td>13</td><td></td><td></td><td></td><td></td><td></td><td></td><td>6</td><td>5</td><td>4</td><td></td><td></td><td></td><td>1</td></tr> </table>	72	70	68					63	62		59	58	57					53	52	51		48	47		44	42	41	40	39	38						34	33	73			32		30			26	25			22	21	20				17				15	14	13							6	5	4				1				
72	70	68					63	62		59	58	57					53																																																																					
52	51		48	47		44	42	41	40	39	38						34	33																																																																				
73			32		30			26	25			22	21	20				17																																																																				
			15	14	13							6	5	4				1																																																																				
AVAILABLE	NOT APPLICABLE	34566-4043	G	0	A	BLACK	<table border="1"> <tr><td></td><td>71</td><td>70</td><td>69</td><td></td><td>67</td><td></td><td></td><td>64</td><td>63</td><td></td><td>60</td><td></td><td></td><td>57</td><td>56</td><td>55</td><td>54</td><td>53</td></tr> <tr><td>52</td><td>51</td><td></td><td>49</td><td></td><td></td><td>45</td><td>44</td><td>43</td><td>42</td><td>41</td><td></td><td></td><td></td><td>37</td><td>36</td><td></td><td></td><td>34</td></tr> <tr><td colspan="2">73</td><td></td><td>32</td><td></td><td>30</td><td></td><td>28</td><td>26</td><td></td><td></td><td>23</td><td></td><td></td><td></td><td></td><td>19</td><td>18</td><td></td></tr> <tr><td colspan="2"></td><td></td><td>16</td><td>15</td><td></td><td></td><td>12</td><td>10</td><td></td><td></td><td></td><td></td><td></td><td></td><td></td><td>3</td><td></td><td></td></tr> </table>		71	70	69		67			64	63		60			57	56	55	54	53	52	51		49			45	44	43	42	41				37	36			34	73			32		30		28	26			23					19	18					16	15			12	10								3					
	71	70	69		67			64	63		60			57	56	55	54	53																																																																				
52	51		49			45	44	43	42	41				37	36			34																																																																				
73			32		30		28	26			23					19	18																																																																					
			16	15			12	10								3																																																																						
AVAILABLE	NOT APPLICABLE	34566-4053	G	0	A	BLACK	<table border="1"> <tr><td>72</td><td></td><td></td><td>69</td><td>67</td><td>66</td><td>65</td><td></td><td>63</td><td></td><td>60</td><td></td><td></td><td>57</td><td>56</td><td></td><td></td><td></td><td>53</td></tr> <tr><td></td><td></td><td></td><td>49</td><td></td><td>47</td><td>46</td><td></td><td>44</td><td>43</td><td>42</td><td>40</td><td></td><td>37</td><td>36</td><td>35</td><td></td><td></td><td>33</td></tr> <tr><td colspan="2">73</td><td></td><td>31</td><td>30</td><td>29</td><td>28</td><td>27</td><td>26</td><td></td><td>24</td><td></td><td>21</td><td>20</td><td></td><td></td><td></td><td></td><td>17</td></tr> <tr><td colspan="2"></td><td></td><td>16</td><td>15</td><td>14</td><td>13</td><td></td><td>11</td><td>10</td><td></td><td></td><td></td><td>5</td><td>4</td><td>3</td><td>2</td><td></td><td>1</td></tr> </table>	72			69	67	66	65		63		60			57	56				53				49		47	46		44	43	42	40		37	36	35			33	73			31	30	29	28	27	26		24		21	20					17				16	15	14	13		11	10				5	4	3	2		1			
72			69	67	66	65		63		60			57	56				53																																																																				
			49		47	46		44	43	42	40		37	36	35			33																																																																				
73			31	30	29	28	27	26		24		21	20					17																																																																				
			16	15	14	13		11	10				5	4	3	2		1																																																																				
AVAILABLE	NOT APPLICABLE	34566-4063	G	0	B	ST GRAY	<table border="1"> <tr><td></td><td></td><td></td><td>68</td><td>67</td><td></td><td></td><td>64</td><td></td><td></td><td></td><td>59</td><td>58</td><td></td><td></td><td></td><td></td><td></td><td>54</td></tr> <tr><td></td><td></td><td></td><td></td><td></td><td>46</td><td>45</td><td></td><td></td><td></td><td></td><td>39</td><td>38</td><td></td><td></td><td></td><td></td><td></td><td>17</td></tr> <tr><td colspan="2">73</td><td></td><td>32</td><td></td><td>30</td><td>29</td><td>28</td><td>27</td><td></td><td></td><td>23</td><td>22</td><td></td><td></td><td></td><td></td><td></td><td>1</td></tr> <tr><td colspan="2"></td><td></td><td>15</td><td></td><td>13</td><td></td><td></td><td>10</td><td>8</td><td></td><td></td><td></td><td></td><td></td><td></td><td></td><td></td><td></td></tr> </table>				68	67			64				59	58						54						46	45					39	38						17	73			32		30	29	28	27			23	22						1				15		13			10	8												
			68	67			64				59	58						54																																																																				
					46	45					39	38						17																																																																				
73			32		30	29	28	27			23	22						1																																																																				
			15		13			10	8																																																																													
AVAILABLE	NOT APPLICABLE	34566-4073	G	0	A	BLACK	<table border="1"> <tr><td>72</td><td>70</td><td></td><td></td><td></td><td>66</td><td></td><td></td><td>63</td><td>62</td><td></td><td>59</td><td></td><td>57</td><td>56</td><td>55</td><td></td><td></td><td>53</td></tr> <tr><td>52</td><td>51</td><td></td><td></td><td></td><td>46</td><td></td><td>44</td><td>42</td><td>41</td><td>40</td><td>39</td><td></td><td>37</td><td>36</td><td></td><td></td><td></td><td>34</td><td>33</td></tr> <tr><td colspan="2">73</td><td></td><td>32</td><td></td><td>30</td><td></td><td></td><td>26</td><td>25</td><td></td><td></td><td>22</td><td>21</td><td>19</td><td>18</td><td></td><td></td><td></td><td></td></tr> <tr><td colspan="2"></td><td></td><td>15</td><td>14</td><td></td><td></td><td></td><td>10</td><td>9</td><td></td><td></td><td>6</td><td></td><td>3</td><td></td><td></td><td></td><td></td><td></td></tr> </table>	72	70				66			63	62		59		57	56	55			53	52	51				46		44	42	41	40	39		37	36				34	33	73			32		30			26	25			22	21	19	18								15	14				10	9			6		3					
72	70				66			63	62		59		57	56	55			53																																																																				
52	51				46		44	42	41	40	39		37	36				34	33																																																																			
73			32		30			26	25			22	21	19	18																																																																							
			15	14				10	9			6		3																																																																								

ENTER DESCRIPTION IEC NO: UAU2014-0376 DRAWN BY: CHYD APPR: WOSHY 2013/09/05 2013/09/06 DESCRIPTION	QUALITY SYMBOLS	GENERAL TOLERANCES (UNLESS SPECIFIED)	DIMENSION STYLE	SCALE	DESIGN UNITS	THIRD ANGLE PROJECTION
	▽=0	mm INCH	MM ONLY		METRIC	
	▽=0	4 PLACES ± --- ± ---	DRAWN BY: SKRA JENDRANA	DATE: 2011/02/14	TITLE:	MX123
	▽=0	3 PLACES ± --- ± ---	CHECKED BY: MVANSLAMBROU	DATE: 2011/02/14		66/73/80CKT
	2 PLACES ± --- ± ---	1 PLACE ± --- ± ---	APPROVED BY:	DATE:		HRNS CONN ASSY
	0 PLACE ± --- ± ---	ANGULAR ± ---°	MATERIAL NO.	DOCUMENT NO.		molex
	DRAFT WHERE APPLICABLE MUST REMAIN WITHIN DIMENSIONS	SEE BOM TABLE				SD-34566-001
		SIZE D	THIS DRAWING CONTAINS INFORMATION THAT IS PROPRIETARY TO MOLEX INCORPORATED AND SHOULD NOT BE USED WITHOUT WRITTEN PERMISSION			

STATUS	GM PART #	MATERIAL #	PART/MATERIAL REVISION	WIRE DRESS OPTION	KEY OPTION	COLOR (TPA)	NUMBERS INDICATE CAVITIES OPEN FOR CIRCUITS																																																																																
AVAILABLE	NOT APPLICABLE	34566-4083	G	0	C	BLUE	<table border="1"> <tr><td>72</td><td>70</td><td>68</td><td></td><td></td><td></td><td>63</td><td>62</td><td></td><td></td><td>59</td><td>58</td><td>57</td><td></td><td></td><td>53</td></tr> <tr><td>52</td><td>51</td><td></td><td>48</td><td>47</td><td></td><td>44</td><td>42</td><td></td><td>40</td><td>39</td><td>38</td><td>37</td><td>36</td><td></td><td>34</td><td>33</td></tr> <tr><td></td><td></td><td></td><td>32</td><td></td><td>30</td><td></td><td></td><td></td><td>27</td><td>26</td><td>25</td><td>24</td><td></td><td>22</td><td>21</td><td>20</td><td>17</td></tr> <tr><td></td><td></td><td></td><td></td><td></td><td>15</td><td>14</td><td>13</td><td></td><td></td><td></td><td>8</td><td></td><td>6</td><td>5</td><td>4</td><td></td><td>2</td><td>1</td></tr> </table>	72	70	68				63	62			59	58	57			53	52	51		48	47		44	42		40	39	38	37	36		34	33				32		30				27	26	25	24		22	21	20	17						15	14	13				8		6	5	4		2	1										
72	70	68				63	62			59	58	57			53																																																																								
52	51		48	47		44	42		40	39	38	37	36		34	33																																																																							
			32		30				27	26	25	24		22	21	20	17																																																																						
					15	14	13				8		6	5	4		2	1																																																																					
AVAILABLE	NOT APPLICABLE	34566-4093	G	0	A	BLACK	<table border="1"> <tr><td></td><td>71</td><td>70</td><td>69</td><td></td><td>67</td><td></td><td></td><td>64</td><td>63</td><td></td><td></td><td>60</td><td></td><td></td><td>57</td><td>56</td><td>55</td><td>54</td><td>53</td></tr> <tr><td></td><td>52</td><td>51</td><td></td><td>49</td><td></td><td>47</td><td></td><td>45</td><td>44</td><td>43</td><td>42</td><td>41</td><td></td><td></td><td>37</td><td>36</td><td></td><td>34</td><td></td></tr> <tr><td></td><td></td><td></td><td></td><td></td><td></td><td>32</td><td></td><td>30</td><td></td><td>28</td><td></td><td>26</td><td></td><td>23</td><td></td><td></td><td>19</td><td>18</td><td></td></tr> <tr><td></td><td></td><td></td><td></td><td></td><td></td><td>16</td><td>15</td><td></td><td></td><td>12</td><td>10</td><td></td><td></td><td></td><td></td><td></td><td>3</td><td></td><td></td></tr> </table>		71	70	69		67			64	63			60			57	56	55	54	53		52	51		49		47		45	44	43	42	41			37	36		34								32		30		28		26		23			19	18								16	15			12	10						3		
	71	70	69		67			64	63			60			57	56	55	54	53																																																																				
	52	51		49		47		45	44	43	42	41			37	36		34																																																																					
						32		30		28		26		23			19	18																																																																					
						16	15			12	10						3																																																																						
AVAILABLE	NOT APPLICABLE	34566-4113	G	0	B	ST GRAY	<table border="1"> <tr><td></td><td></td><td></td><td>68</td><td>67</td><td></td><td>64</td><td></td><td></td><td></td><td></td><td></td><td></td><td></td><td>58</td><td></td><td></td><td></td><td></td><td></td></tr> <tr><td></td><td></td><td></td><td></td><td></td><td></td><td>46</td><td>45</td><td></td><td></td><td></td><td></td><td></td><td></td><td>38</td><td></td><td></td><td></td><td></td><td></td></tr> <tr><td></td><td></td><td></td><td></td><td></td><td></td><td>32</td><td></td><td>30</td><td>29</td><td>28</td><td>27</td><td></td><td></td><td>22</td><td></td><td></td><td></td><td></td><td>17</td></tr> <tr><td></td><td></td><td></td><td></td><td></td><td></td><td></td><td></td><td>15</td><td>13</td><td></td><td>10</td><td></td><td></td><td></td><td></td><td></td><td></td><td></td><td>1</td></tr> </table>				68	67		64								58												46	45							38												32		30	29	28	27			22					17									15	13		10								1
			68	67		64								58																																																																									
						46	45							38																																																																									
						32		30	29	28	27			22					17																																																																				
								15	13		10								1																																																																				
AVAILABLE	NOT APPLICABLE	34566-4123	G	9	A	BLACK	<table border="1"> <tr><td>72</td><td></td><td>69</td><td></td><td>67</td><td>66</td><td>65</td><td></td><td>63</td><td></td><td>60</td><td></td><td></td><td>57</td><td>56</td><td></td><td></td><td></td><td>53</td></tr> <tr><td></td><td></td><td>49</td><td></td><td>47</td><td>46</td><td></td><td>44</td><td>43</td><td>42</td><td>40</td><td></td><td></td><td>37</td><td>36</td><td>35</td><td></td><td></td><td>33</td></tr> <tr><td></td><td></td><td></td><td></td><td>31</td><td>30</td><td>29</td><td>28</td><td></td><td>26</td><td>24</td><td></td><td></td><td>21</td><td>20</td><td></td><td></td><td></td><td>17</td></tr> <tr><td></td><td></td><td></td><td></td><td>16</td><td>15</td><td>14</td><td>13</td><td></td><td>11</td><td>10</td><td></td><td></td><td></td><td>5</td><td>4</td><td>3</td><td>2</td><td>1</td></tr> </table>	72		69		67	66	65		63		60			57	56				53			49		47	46		44	43	42	40			37	36	35			33					31	30	29	28		26	24			21	20				17					16	15	14	13		11	10				5	4	3	2	1				
72		69		67	66	65		63		60			57	56				53																																																																					
		49		47	46		44	43	42	40			37	36	35			33																																																																					
				31	30	29	28		26	24			21	20				17																																																																					
				16	15	14	13		11	10				5	4	3	2	1																																																																					
AVAILABLE	NOT APPLICABLE	34566-4133	G	9	B	ST GRAY	<table border="1"> <tr><td></td><td></td><td></td><td>68</td><td>67</td><td></td><td>64</td><td></td><td></td><td></td><td></td><td></td><td>59</td><td>58</td><td></td><td></td><td></td><td></td><td>54</td></tr> <tr><td></td><td></td><td></td><td></td><td></td><td></td><td>46</td><td>45</td><td></td><td></td><td></td><td></td><td>39</td><td>38</td><td></td><td></td><td></td><td></td><td></td></tr> <tr><td></td><td></td><td></td><td></td><td></td><td></td><td>32</td><td></td><td>30</td><td>29</td><td>28</td><td>27</td><td></td><td></td><td>23</td><td>22</td><td></td><td></td><td>17</td></tr> <tr><td></td><td></td><td></td><td></td><td></td><td></td><td></td><td></td><td>15</td><td>13</td><td></td><td>10</td><td>9</td><td>8</td><td></td><td></td><td></td><td></td><td>1</td></tr> </table>				68	67		64						59	58					54							46	45					39	38												32		30	29	28	27			23	22			17									15	13		10	9	8					1				
			68	67		64						59	58					54																																																																					
						46	45					39	38																																																																										
						32		30	29	28	27			23	22			17																																																																					
								15	13		10	9	8					1																																																																					
AVAILABLE	NOT APPLICABLE	34566-4143	G	0	B	ST GRAY	<table border="1"> <tr><td></td><td></td><td></td><td>68</td><td>67</td><td></td><td>64</td><td></td><td></td><td></td><td></td><td></td><td>59</td><td>58</td><td></td><td></td><td></td><td></td><td>54</td></tr> <tr><td></td><td></td><td></td><td></td><td></td><td></td><td>46</td><td>45</td><td></td><td></td><td></td><td></td><td>39</td><td>38</td><td></td><td></td><td></td><td></td><td></td></tr> <tr><td></td><td></td><td></td><td></td><td></td><td></td><td>32</td><td></td><td>30</td><td>29</td><td>28</td><td>27</td><td></td><td></td><td>23</td><td>22</td><td></td><td></td><td>17</td></tr> <tr><td></td><td></td><td></td><td></td><td></td><td></td><td></td><td></td><td></td><td></td><td>10</td><td>9</td><td></td><td></td><td></td><td></td><td></td><td></td><td>1</td></tr> </table>				68	67		64						59	58					54							46	45					39	38												32		30	29	28	27			23	22			17											10	9							1				
			68	67		64						59	58					54																																																																					
						46	45					39	38																																																																										
						32		30	29	28	27			23	22			17																																																																					
										10	9							1																																																																					
AVAILABLE	NOT APPLICABLE	34566-4153	G	0	B	ST GRAY	<table border="1"> <tr><td>72</td><td>70</td><td>68</td><td></td><td>66</td><td></td><td></td><td></td><td></td><td></td><td>60</td><td>59</td><td></td><td></td><td></td><td>55</td><td>54</td><td>53</td></tr> <tr><td>52</td><td>50</td><td></td><td>48</td><td>46</td><td></td><td>44</td><td></td><td></td><td></td><td>40</td><td>39</td><td></td><td></td><td></td><td>35</td><td>34</td><td>33</td></tr> <tr><td></td><td></td><td></td><td>32</td><td>31</td><td>30</td><td>29</td><td>28</td><td>27</td><td>26</td><td>25</td><td>24</td><td>23</td><td></td><td></td><td>19</td><td>18</td><td></td></tr> <tr><td></td><td></td><td></td><td></td><td></td><td></td><td></td><td></td><td></td><td>10</td><td>9</td><td>8</td><td>7</td><td></td><td></td><td></td><td></td><td></td></tr> </table>	72	70	68		66						60	59				55	54	53	52	50		48	46		44				40	39				35	34	33				32	31	30	29	28	27	26	25	24	23			19	18											10	9	8	7													
72	70	68		66						60	59				55	54	53																																																																						
52	50		48	46		44				40	39				35	34	33																																																																						
			32	31	30	29	28	27	26	25	24	23			19	18																																																																							
									10	9	8	7																																																																											
AVAILABLE	NOT APPLICABLE	34566-4163	G	0	B	ST GRAY	<table border="1"> <tr><td>72</td><td>70</td><td>68</td><td></td><td>66</td><td></td><td></td><td></td><td></td><td></td><td>60</td><td>59</td><td></td><td></td><td></td><td>55</td><td>54</td><td>53</td></tr> <tr><td>52</td><td>50</td><td></td><td>48</td><td>46</td><td></td><td>44</td><td></td><td></td><td></td><td>40</td><td>39</td><td></td><td></td><td></td><td>35</td><td>34</td><td>33</td></tr> <tr><td></td><td></td><td></td><td>32</td><td>31</td><td>30</td><td>29</td><td>28</td><td>27</td><td>26</td><td>25</td><td>24</td><td>23</td><td></td><td></td><td>19</td><td>18</td><td></td></tr> <tr><td></td><td></td><td></td><td></td><td></td><td></td><td></td><td></td><td></td><td>10</td><td>9</td><td>8</td><td>7</td><td></td><td></td><td></td><td></td><td>1</td></tr> </table>	72	70	68		66						60	59				55	54	53	52	50		48	46		44				40	39				35	34	33				32	31	30	29	28	27	26	25	24	23			19	18											10	9	8	7					1								
72	70	68		66						60	59				55	54	53																																																																						
52	50		48	46		44				40	39				35	34	33																																																																						
			32	31	30	29	28	27	26	25	24	23			19	18																																																																							
									10	9	8	7					1																																																																						
AVAILABLE	NOT APPLICABLE	34566-4173	G	0	A	BLACK	<table border="1"> <tr><td>72</td><td>71</td><td>70</td><td>69</td><td></td><td></td><td></td><td></td><td>64</td><td>63</td><td></td><td></td><td>60</td><td>59</td><td>58</td><td></td><td>56</td><td>55</td><td>54</td><td>53</td></tr> <tr><td>52</td><td>51</td><td></td><td>49</td><td></td><td>47</td><td></td><td>45</td><td>44</td><td>43</td><td>42</td><td>41</td><td></td><td></td><td>38</td><td></td><td>36</td><td></td><td>34</td><td></td></tr> <tr><td></td><td></td><td></td><td></td><td></td><td>32</td><td></td><td>30</td><td></td><td>28</td><td></td><td>26</td><td>25</td><td></td><td></td><td>21</td><td></td><td>19</td><td>18</td><td></td></tr> <tr><td></td><td></td><td></td><td></td><td></td><td></td><td></td><td>16</td><td>15</td><td></td><td>12</td><td>10</td><td>9</td><td>8</td><td></td><td>5</td><td></td><td>3</td><td></td><td></td></tr> </table>	72	71	70	69					64	63			60	59	58		56	55	54	53	52	51		49		47		45	44	43	42	41			38		36		34							32		30		28		26	25			21		19	18									16	15		12	10	9	8		5		3		
72	71	70	69					64	63			60	59	58		56	55	54	53																																																																				
52	51		49		47		45	44	43	42	41			38		36		34																																																																					
					32		30		28		26	25			21		19	18																																																																					
							16	15		12	10	9	8		5		3																																																																						

ENTER DESCRIPTION IEC NO: UAU2014-0376 DRAWN BY: CHYK CHCK: APPR: IKOSHY 2013/09/05 2013/09/06	QUALITY SYMBOLS	GENERAL TOLERANCES (UNLESS SPECIFIED)	DIMENSION STYLE	SCALE	DESIGN UNITS	THIRD ANGLE PROJECTION	
	∇=0 ∇=0 ∇=0	4 PLACES ±---+--- 3 PLACES ±---+--- 2 PLACES ±---+--- 1 PLACE ±---+--- 0 PLACE ±---+---	mm INCH ±--- ±--- ±--- ±--- ±--- ±--- ±--- ±--- ±--- ±---	MM ONLY		METRIC	DRAWN BY: SKRAJENDRANA 2011/02/14 CHECKED BY: MYANSLAMBROU 2011/02/14 APPROVED BY:
	ANGULAR ±---° DRAFT WHERE APPLICABLE MUST REMAIN WITHIN DIMENSIONS		MATERIAL NO. SEE BOM TABLE	DATE TITLE 2011/02/14 66/73/80CKT HRNS CONN ASSY	DOCUMENT NO. SD-34566-001		SHEET NO. 48 OF 68
	THIS DRAWING CONTAINS INFORMATION THAT IS PROPRIETARY TO MOLEX INCORPORATED AND SHOULD NOT BE USED WITHOUT WRITTEN PERMISSION						MOLEX

STATUS	GM PART #	MATERIAL #	PART/MATERIAL REVISION	WIRE DRESS OPTION	KEY OPTION	COLOR (TPA)	NUMBERS INDICATE CAVITIES OPEN FOR CIRCUITS																																																																																																									
AVAILABLE	NOT APPLICABLE	34566-4183	G	0	C	BLUE	<table border="1"> <tr><td>72</td><td>70</td><td>68</td><td>66</td><td></td><td>63</td><td>62</td><td></td><td>59</td><td>58</td><td>57</td><td></td><td></td><td>53</td></tr> <tr><td>52</td><td>51</td><td>48</td><td>47</td><td>46</td><td>44</td><td>42</td><td>40</td><td>39</td><td></td><td></td><td></td><td></td><td>34</td><td>33</td></tr> <tr><td></td><td></td><td></td><td></td><td>30</td><td></td><td></td><td></td><td></td><td></td><td></td><td></td><td></td><td></td><td>17</td></tr> <tr><td>73</td><td></td><td></td><td></td><td>15</td><td>14</td><td>13</td><td></td><td>10</td><td>9</td><td>7</td><td>6</td><td>5</td><td>4</td><td>1</td></tr> </table>	72	70	68	66		63	62		59	58	57			53	52	51	48	47	46	44	42	40	39					34	33					30										17	73				15	14	13		10	9	7	6	5	4	1																																														
72	70	68	66		63	62		59	58	57			53																																																																																																			
52	51	48	47	46	44	42	40	39					34	33																																																																																																		
				30										17																																																																																																		
73				15	14	13		10	9	7	6	5	4	1																																																																																																		
AVAILABLE	NOT APPLICABLE	34566-4193	G	0	C	BLUE	<table border="1"> <tr><td></td><td>71</td><td>69</td><td></td><td></td><td>65</td><td>64</td><td></td><td>61</td><td>60</td><td></td><td>58</td><td>56</td><td>55</td><td>54</td></tr> <tr><td></td><td></td><td>50</td><td>49</td><td></td><td>45</td><td>43</td><td></td><td>41</td><td></td><td></td><td>38</td><td>37</td><td>36</td><td>35</td></tr> <tr><td></td><td></td><td></td><td></td><td></td><td>31</td><td>29</td><td>28</td><td></td><td></td><td>24</td><td>23</td><td>22</td><td>21</td><td>20</td></tr> <tr><td>73</td><td></td><td></td><td></td><td>16</td><td></td><td>13</td><td>12</td><td>11</td><td></td><td>8</td><td>7</td><td></td><td></td><td>3</td></tr> <tr><td></td><td></td><td></td><td></td><td></td><td></td><td></td><td></td><td></td><td></td><td></td><td></td><td></td><td></td><td>2</td></tr> <tr><td></td><td></td><td></td><td></td><td></td><td></td><td></td><td></td><td></td><td></td><td></td><td></td><td></td><td></td><td>1</td></tr> </table>		71	69			65	64		61	60		58	56	55	54			50	49		45	43		41			38	37	36	35						31	29	28			24	23	22	21	20	73				16		13	12	11		8	7			3															2															1															
	71	69			65	64		61	60		58	56	55	54																																																																																																		
		50	49		45	43		41			38	37	36	35																																																																																																		
					31	29	28			24	23	22	21	20																																																																																																		
73				16		13	12	11		8	7			3																																																																																																		
														2																																																																																																		
														1																																																																																																		
AVAILABLE	NOT APPLICABLE	34566-4213	G	0	A	BLACK	<table border="1"> <tr><td>72</td><td>71</td><td></td><td>68</td><td>67</td><td>66</td><td>65</td><td>64</td><td></td><td></td><td>60</td><td>59</td><td>58</td><td></td><td></td></tr> <tr><td></td><td></td><td>50</td><td>48</td><td>47</td><td>46</td><td>45</td><td></td><td></td><td></td><td>40</td><td>39</td><td>38</td><td></td><td>35</td></tr> <tr><td></td><td></td><td></td><td></td><td></td><td>31</td><td>30</td><td></td><td></td><td></td><td>25</td><td>24</td><td>22</td><td>21</td><td>20</td></tr> <tr><td>73</td><td></td><td></td><td></td><td></td><td></td><td>14</td><td></td><td></td><td></td><td>9</td><td>7</td><td>6</td><td>5</td><td>4</td></tr> <tr><td></td><td></td><td></td><td></td><td></td><td></td><td></td><td></td><td></td><td></td><td></td><td></td><td></td><td></td><td>2</td></tr> <tr><td></td><td></td><td></td><td></td><td></td><td></td><td></td><td></td><td></td><td></td><td></td><td></td><td></td><td></td><td>1</td></tr> </table>	72	71		68	67	66	65	64			60	59	58					50	48	47	46	45				40	39	38		35						31	30				25	24	22	21	20	73						14				9	7	6	5	4															2															1															
72	71		68	67	66	65	64			60	59	58																																																																																																				
		50	48	47	46	45				40	39	38		35																																																																																																		
					31	30				25	24	22	21	20																																																																																																		
73						14				9	7	6	5	4																																																																																																		
														2																																																																																																		
														1																																																																																																		
AVAILABLE	NOT APPLICABLE	34566-4223	G	0	A	BLACK	<table border="1"> <tr><td>72</td><td>71</td><td></td><td>68</td><td>67</td><td>66</td><td>65</td><td>64</td><td></td><td></td><td>60</td><td>59</td><td>58</td><td></td><td></td></tr> <tr><td></td><td></td><td>50</td><td>48</td><td>47</td><td>46</td><td>45</td><td></td><td></td><td></td><td>40</td><td>39</td><td>38</td><td></td><td>35</td></tr> <tr><td></td><td></td><td></td><td></td><td></td><td>31</td><td>30</td><td></td><td></td><td></td><td>25</td><td>24</td><td>23</td><td>22</td><td>21</td></tr> <tr><td>73</td><td></td><td></td><td></td><td></td><td></td><td>14</td><td></td><td></td><td></td><td>9</td><td>8</td><td>7</td><td>6</td><td>5</td></tr> <tr><td></td><td></td><td></td><td></td><td></td><td></td><td></td><td></td><td></td><td></td><td></td><td></td><td></td><td></td><td>4</td></tr> <tr><td></td><td></td><td></td><td></td><td></td><td></td><td></td><td></td><td></td><td></td><td></td><td></td><td></td><td></td><td>2</td></tr> <tr><td></td><td></td><td></td><td></td><td></td><td></td><td></td><td></td><td></td><td></td><td></td><td></td><td></td><td></td><td>1</td></tr> </table>	72	71		68	67	66	65	64			60	59	58					50	48	47	46	45				40	39	38		35						31	30				25	24	23	22	21	73						14				9	8	7	6	5															4															2															1
72	71		68	67	66	65	64			60	59	58																																																																																																				
		50	48	47	46	45				40	39	38		35																																																																																																		
					31	30				25	24	23	22	21																																																																																																		
73						14				9	8	7	6	5																																																																																																		
														4																																																																																																		
														2																																																																																																		
														1																																																																																																		
AVAILABLE	NOT APPLICABLE	34566-4233	G	0	B	ST GRY	<table border="1"> <tr><td></td><td></td><td>69</td><td></td><td></td><td>65</td><td>64</td><td>63</td><td></td><td></td><td></td><td></td><td></td><td></td><td></td></tr> <tr><td></td><td></td><td></td><td>49</td><td></td><td>45</td><td>44</td><td>43</td><td></td><td></td><td></td><td></td><td></td><td></td><td></td></tr> <tr><td></td><td></td><td></td><td></td><td></td><td></td><td></td><td></td><td></td><td></td><td></td><td>23</td><td>22</td><td>21</td><td>20</td></tr> <tr><td>73</td><td></td><td></td><td></td><td></td><td></td><td></td><td></td><td></td><td></td><td></td><td>7</td><td>6</td><td>5</td><td>4</td></tr> <tr><td></td><td></td><td></td><td></td><td></td><td></td><td></td><td></td><td></td><td></td><td></td><td></td><td></td><td></td><td>3</td></tr> <tr><td></td><td></td><td></td><td></td><td></td><td></td><td></td><td></td><td></td><td></td><td></td><td></td><td></td><td></td><td>18</td></tr> </table>			69			65	64	63											49		45	44	43																			23	22	21	20	73											7	6	5	4															3															18															
		69			65	64	63																																																																																																									
			49		45	44	43																																																																																																									
											23	22	21	20																																																																																																		
73											7	6	5	4																																																																																																		
														3																																																																																																		
														18																																																																																																		
AVAILABLE	NOT APPLICABLE	34566-4243	G	0	A	BLACK	<table border="1"> <tr><td></td><td>51</td><td>50</td><td></td><td>47</td><td>46</td><td></td><td></td><td></td><td>61</td><td></td><td>58</td><td>57</td><td>56</td><td></td></tr> <tr><td></td><td></td><td></td><td></td><td></td><td></td><td></td><td></td><td></td><td></td><td></td><td>38</td><td>37</td><td>36</td><td></td></tr> <tr><td></td><td></td><td></td><td></td><td></td><td>31</td><td>30</td><td></td><td></td><td>26</td><td></td><td>22</td><td>21</td><td>20</td><td></td></tr> <tr><td>73</td><td></td><td></td><td></td><td></td><td></td><td>15</td><td>14</td><td></td><td>10</td><td></td><td></td><td></td><td></td><td></td></tr> </table>		51	50		47	46				61		58	57	56													38	37	36							31	30			26		22	21	20		73						15	14		10																																																		
	51	50		47	46				61		58	57	56																																																																																																			
											38	37	36																																																																																																			
					31	30			26		22	21	20																																																																																																			
73						15	14		10																																																																																																							
AVAILABLE	NOT APPLICABLE	34566-4253	G	0	A	BLACK	<table border="1"> <tr><td></td><td>51</td><td>50</td><td></td><td>47</td><td>46</td><td>45</td><td></td><td></td><td></td><td></td><td>38</td><td>37</td><td>36</td><td></td></tr> <tr><td></td><td></td><td></td><td></td><td></td><td></td><td></td><td></td><td></td><td>26</td><td></td><td>22</td><td>21</td><td>20</td><td></td></tr> <tr><td></td><td></td><td></td><td></td><td></td><td></td><td></td><td></td><td></td><td>10</td><td></td><td></td><td></td><td></td><td></td></tr> <tr><td>73</td><td></td><td></td><td></td><td></td><td></td><td></td><td></td><td></td><td></td><td></td><td></td><td></td><td></td><td></td></tr> </table>		51	50		47	46	45					38	37	36											26		22	21	20											10						73																																																											
	51	50		47	46	45					38	37	36																																																																																																			
									26		22	21	20																																																																																																			
									10																																																																																																							
73																																																																																																																
AVAILABLE	NOT APPLICABLE	34566-4263	G	0	B	ST GRY	<table border="1"> <tr><td>72</td><td>71</td><td>70</td><td>69</td><td>68</td><td></td><td>65</td><td>64</td><td>62</td><td>61</td><td>60</td><td></td><td></td><td></td><td>54</td></tr> <tr><td>52</td><td>51</td><td></td><td></td><td>47</td><td>46</td><td>44</td><td>42</td><td>41</td><td>40</td><td></td><td></td><td></td><td></td><td></td></tr> <tr><td></td><td></td><td></td><td></td><td></td><td>32</td><td>31</td><td>30</td><td>28</td><td>26</td><td>25</td><td>24</td><td></td><td></td><td>20</td></tr> <tr><td>73</td><td></td><td></td><td></td><td></td><td></td><td></td><td></td><td>12</td><td>11</td><td>10</td><td>9</td><td></td><td></td><td>19</td></tr> <tr><td></td><td></td><td></td><td></td><td></td><td></td><td></td><td></td><td></td><td></td><td></td><td></td><td></td><td></td><td>17</td></tr> <tr><td></td><td></td><td></td><td></td><td></td><td></td><td></td><td></td><td></td><td></td><td></td><td></td><td></td><td></td><td>2</td></tr> <tr><td></td><td></td><td></td><td></td><td></td><td></td><td></td><td></td><td></td><td></td><td></td><td></td><td></td><td></td><td>1</td></tr> </table>	72	71	70	69	68		65	64	62	61	60				54	52	51			47	46	44	42	41	40											32	31	30	28	26	25	24			20	73								12	11	10	9			19															17															2															1
72	71	70	69	68		65	64	62	61	60				54																																																																																																		
52	51			47	46	44	42	41	40																																																																																																							
					32	31	30	28	26	25	24			20																																																																																																		
73								12	11	10	9			19																																																																																																		
														17																																																																																																		
														2																																																																																																		
														1																																																																																																		
AVAILABLE	NOT APPLICABLE	34566-4273	G	0	B	ST GRY	<table border="1"> <tr><td>72</td><td>71</td><td>70</td><td>69</td><td>68</td><td>67</td><td>66</td><td>65</td><td>64</td><td>62</td><td>61</td><td>60</td><td></td><td></td><td>54</td></tr> <tr><td>52</td><td>51</td><td></td><td></td><td>47</td><td>45</td><td>44</td><td>42</td><td>41</td><td>40</td><td></td><td></td><td></td><td></td><td></td></tr> <tr><td></td><td></td><td></td><td></td><td></td><td>32</td><td>31</td><td>30</td><td>28</td><td>26</td><td>25</td><td>24</td><td></td><td></td><td>20</td></tr> <tr><td>73</td><td></td><td></td><td></td><td></td><td></td><td></td><td></td><td>13</td><td>12</td><td>11</td><td>10</td><td>9</td><td>8</td><td>19</td></tr> <tr><td></td><td></td><td></td><td></td><td></td><td></td><td></td><td></td><td></td><td></td><td></td><td></td><td></td><td></td><td>17</td></tr> <tr><td></td><td></td><td></td><td></td><td></td><td></td><td></td><td></td><td></td><td></td><td></td><td></td><td></td><td></td><td>2</td></tr> <tr><td></td><td></td><td></td><td></td><td></td><td></td><td></td><td></td><td></td><td></td><td></td><td></td><td></td><td></td><td>1</td></tr> </table>	72	71	70	69	68	67	66	65	64	62	61	60			54	52	51			47	45	44	42	41	40											32	31	30	28	26	25	24			20	73								13	12	11	10	9	8	19															17															2															1
72	71	70	69	68	67	66	65	64	62	61	60			54																																																																																																		
52	51			47	45	44	42	41	40																																																																																																							
					32	31	30	28	26	25	24			20																																																																																																		
73								13	12	11	10	9	8	19																																																																																																		
														17																																																																																																		
														2																																																																																																		
														1																																																																																																		

ENTER DESCRIPTION EC NO: UAU2014-0376 DRAWN BY: CHKO CHKD: APPR:KOSHY 2013/09/05 2013/09/06 REV:	QUALITY SYMBOLS ∇=0 ∇=0 ∇=0	GENERAL TOLERANCES (UNLESS SPECIFIED) <table border="1"> <tr><th></th><th>mm</th><th>INCH</th></tr> <tr><td>4 PLACES</td><td>±----</td><td>±----</td></tr> <tr><td>3 PLACES</td><td>±----</td><td>±----</td></tr> <tr><td>2 PLACES</td><td>±----</td><td>±----</td></tr> <tr><td>1 PLACE</td><td>±----</td><td>±----</td></tr> <tr><td>0 PLACE</td><td>±----</td><td>±----</td></tr> </table>		mm	INCH	4 PLACES	±----	±----	3 PLACES	±----	±----	2 PLACES	±----	±----	1 PLACE	±----	±----	0 PLACE	±----	±----	DIMENSION STYLE MM ONLY	SCALE METRIC	DESIGN UNITS METRIC	THIRD ANGLE PROJECTION
		mm	INCH																					
4 PLACES	±----	±----																						
3 PLACES	±----	±----																						
2 PLACES	±----	±----																						
1 PLACE	±----	±----																						
0 PLACE	±----	±----																						
DRAWN BY: SKRA JENDRANA 2011/02/14 CHECKED BY: MYANSLAMBROU 2011/02/14 APPROVED BY:	DATE:	TITLE: MX123 66/73/80CKT HRNS CONN ASSY	MATERIAL NO: SD-34566-001	DOCUMENT NO:	SHEET NO: 49 OF 68	THIS DRAWING CONTAINS INFORMATION THAT IS PROPRIETARY TO MOLEX INCORPORATED AND SHOULD NOT BE USED WITHOUT WRITTEN PERMISSION																		

STATUS	GM PART #	MATERIAL #	PART/MATERIAL REVISION	WIRE DRESS OPTION	KEY OPTION	COLOR (TPA)	NUMBERS INDICATE CAVITIES OPEN FOR CIRCUITS																																																																																			
AVAILABLE	NOT APPLICABLE	34566-4283	G	0	A	BLACK	<table border="1"> <tr><td></td><td>70</td><td>69</td><td></td><td></td><td></td><td></td><td>63</td><td>62</td><td>61</td><td>60</td><td></td><td></td><td>57</td><td>56</td><td>55</td><td>54</td><td>53</td></tr> <tr><td>52</td><td>51</td><td>49</td><td></td><td></td><td></td><td></td><td>44</td><td>43</td><td>42</td><td>41</td><td></td><td></td><td></td><td>37</td><td>36</td><td></td><td>34</td></tr> <tr><td></td><td></td><td></td><td>32</td><td></td><td></td><td></td><td>29</td><td>28</td><td>27</td><td>26</td><td></td><td></td><td>23</td><td></td><td></td><td></td><td>19</td><td>18</td></tr> <tr><td></td><td></td><td></td><td>16</td><td>15</td><td></td><td></td><td>13</td><td>12</td><td>11</td><td>10</td><td></td><td></td><td>8</td><td></td><td></td><td></td><td>3</td><td></td></tr> </table>		70	69					63	62	61	60			57	56	55	54	53	52	51	49					44	43	42	41				37	36		34				32				29	28	27	26			23				19	18				16	15			13	12	11	10			8				3										
	70	69					63	62	61	60			57	56	55	54	53																																																																									
52	51	49					44	43	42	41				37	36		34																																																																									
			32				29	28	27	26			23				19	18																																																																								
			16	15			13	12	11	10			8				3																																																																									
AVAILABLE	NOT APPLICABLE	34566-4293	G	0	B	ST GRAY	<table border="1"> <tr><td></td><td></td><td></td><td></td><td>67</td><td>66</td><td></td><td></td><td>63</td><td></td><td></td><td></td><td></td><td>59</td><td>58</td><td>57</td><td>56</td><td>55</td><td>53</td></tr> <tr><td></td><td></td><td>50</td><td>49</td><td>48</td><td></td><td></td><td>45</td><td>43</td><td></td><td></td><td></td><td></td><td>39</td><td>38</td><td>37</td><td>36</td><td>35</td><td>34</td><td>33</td></tr> <tr><td></td><td></td><td></td><td></td><td></td><td></td><td></td><td>29</td><td>27</td><td></td><td></td><td></td><td></td><td>23</td><td>22</td><td>21</td><td></td><td></td><td>18</td><td></td></tr> <tr><td></td><td></td><td></td><td></td><td></td><td></td><td></td><td>16</td><td>15</td><td>14</td><td>13</td><td></td><td></td><td>8</td><td>7</td><td>6</td><td>5</td><td>4</td><td>3</td><td></td></tr> </table>					67	66			63					59	58	57	56	55	53			50	49	48			45	43					39	38	37	36	35	34	33								29	27					23	22	21			18									16	15	14	13			8	7	6	5	4	3					
				67	66			63					59	58	57	56	55	53																																																																								
		50	49	48			45	43					39	38	37	36	35	34	33																																																																							
							29	27					23	22	21			18																																																																								
							16	15	14	13			8	7	6	5	4	3																																																																								
AVAILABLE	NOT APPLICABLE	34566-4313	G	0	B	ST GRAY	<table border="1"> <tr><td></td><td></td><td></td><td></td><td></td><td></td><td></td><td></td><td>63</td><td></td><td></td><td></td><td></td><td>59</td><td>58</td><td>57</td><td>56</td><td>55</td><td>53</td></tr> <tr><td></td><td></td><td>50</td><td>49</td><td>48</td><td></td><td></td><td>46</td><td>43</td><td></td><td></td><td></td><td></td><td>39</td><td>38</td><td>37</td><td>36</td><td>35</td><td>34</td><td>33</td></tr> <tr><td></td><td></td><td></td><td></td><td></td><td></td><td></td><td>29</td><td>27</td><td></td><td></td><td></td><td></td><td>23</td><td>22</td><td>21</td><td></td><td></td><td>18</td><td></td></tr> <tr><td></td><td></td><td></td><td></td><td></td><td></td><td></td><td>16</td><td>15</td><td>14</td><td>13</td><td></td><td></td><td>7</td><td>6</td><td>5</td><td>4</td><td>3</td><td></td><td></td></tr> </table>									63					59	58	57	56	55	53			50	49	48			46	43					39	38	37	36	35	34	33								29	27					23	22	21			18									16	15	14	13			7	6	5	4	3						
								63					59	58	57	56	55	53																																																																								
		50	49	48			46	43					39	38	37	36	35	34	33																																																																							
							29	27					23	22	21			18																																																																								
							16	15	14	13			7	6	5	4	3																																																																									
AVAILABLE	NOT APPLICABLE	34566-4323	G	0	B	ST GRAY	<table border="1"> <tr><td>72</td><td>70</td><td>68</td><td></td><td>66</td><td></td><td></td><td></td><td></td><td></td><td>60</td><td>59</td><td></td><td></td><td></td><td></td><td>55</td><td>54</td><td>53</td></tr> <tr><td>52</td><td>51</td><td>48</td><td></td><td>46</td><td></td><td></td><td></td><td></td><td></td><td>40</td><td>39</td><td></td><td></td><td></td><td></td><td>35</td><td>34</td><td>33</td></tr> <tr><td></td><td></td><td>32</td><td>31</td><td>30</td><td>29</td><td>28</td><td>27</td><td>26</td><td>25</td><td>24</td><td></td><td></td><td></td><td></td><td></td><td>19</td><td>18</td><td>17</td></tr> <tr><td></td><td></td><td>16</td><td></td><td></td><td></td><td></td><td></td><td>10</td><td></td><td>8</td><td>7</td><td></td><td></td><td></td><td></td><td></td><td></td><td>2</td><td>1</td></tr> </table>	72	70	68		66						60	59					55	54	53	52	51	48		46						40	39					35	34	33			32	31	30	29	28	27	26	25	24						19	18	17			16						10		8	7							2	1						
72	70	68		66						60	59					55	54	53																																																																								
52	51	48		46						40	39					35	34	33																																																																								
		32	31	30	29	28	27	26	25	24						19	18	17																																																																								
		16						10		8	7							2	1																																																																							
AVAILABLE	NOT APPLICABLE	34566-4333	G	0	A	BLACK	<table border="1"> <tr><td>72</td><td>71</td><td>70</td><td>69</td><td></td><td>67</td><td></td><td></td><td>64</td><td>63</td><td></td><td></td><td>60</td><td>59</td><td></td><td></td><td>56</td><td>55</td><td>54</td><td>53</td></tr> <tr><td>52</td><td>51</td><td>49</td><td></td><td></td><td>47</td><td></td><td></td><td>45</td><td>44</td><td>43</td><td>42</td><td>41</td><td></td><td></td><td>38</td><td></td><td>36</td><td></td><td>34</td></tr> <tr><td></td><td></td><td></td><td>32</td><td></td><td>30</td><td></td><td></td><td>28</td><td></td><td>26</td><td>25</td><td></td><td>23</td><td></td><td></td><td></td><td></td><td>19</td><td>18</td></tr> <tr><td></td><td></td><td></td><td>16</td><td>15</td><td></td><td></td><td></td><td>12</td><td>10</td><td>9</td><td></td><td></td><td></td><td></td><td></td><td></td><td></td><td>3</td><td></td></tr> </table>	72	71	70	69		67			64	63			60	59			56	55	54	53	52	51	49			47			45	44	43	42	41			38		36		34				32		30			28		26	25		23					19	18				16	15				12	10	9								3				
72	71	70	69		67			64	63			60	59			56	55	54	53																																																																							
52	51	49			47			45	44	43	42	41			38		36		34																																																																							
			32		30			28		26	25		23					19	18																																																																							
			16	15				12	10	9								3																																																																								
AVAILABLE	NOT APPLICABLE	34566-4343	G	0	A	BLACK	<table border="1"> <tr><td>72</td><td>71</td><td>70</td><td>69</td><td></td><td></td><td></td><td></td><td>64</td><td>63</td><td></td><td></td><td>60</td><td>59</td><td>58</td><td></td><td>56</td><td>55</td><td>54</td><td>53</td></tr> <tr><td>52</td><td>51</td><td>49</td><td></td><td></td><td>47</td><td></td><td></td><td>45</td><td>44</td><td>43</td><td>42</td><td>41</td><td></td><td></td><td>38</td><td></td><td>36</td><td></td><td>34</td></tr> <tr><td></td><td></td><td></td><td>32</td><td></td><td>30</td><td></td><td></td><td>28</td><td></td><td>26</td><td>25</td><td></td><td></td><td></td><td></td><td></td><td></td><td>19</td><td>18</td></tr> <tr><td></td><td></td><td></td><td>16</td><td>15</td><td></td><td></td><td></td><td>12</td><td>10</td><td>9</td><td></td><td></td><td></td><td></td><td></td><td></td><td></td><td>3</td><td></td></tr> </table>	72	71	70	69					64	63			60	59	58		56	55	54	53	52	51	49			47			45	44	43	42	41			38		36		34				32		30			28		26	25							19	18				16	15				12	10	9								3				
72	71	70	69					64	63			60	59	58		56	55	54	53																																																																							
52	51	49			47			45	44	43	42	41			38		36		34																																																																							
			32		30			28		26	25							19	18																																																																							
			16	15				12	10	9								3																																																																								
AVAILABLE	NOT APPLICABLE	34566-4353	G	0	C	BLUE	<table border="1"> <tr><td>72</td><td>70</td><td>68</td><td></td><td></td><td></td><td></td><td></td><td>63</td><td>62</td><td></td><td></td><td>59</td><td>58</td><td>57</td><td></td><td></td><td></td><td></td><td>53</td></tr> <tr><td>52</td><td>51</td><td></td><td>48</td><td>47</td><td></td><td></td><td>44</td><td>42</td><td>40</td><td>39</td><td></td><td></td><td></td><td></td><td></td><td></td><td></td><td></td><td>34</td><td>33</td></tr> <tr><td></td><td></td><td></td><td>32</td><td></td><td>30</td><td></td><td></td><td>26</td><td>25</td><td></td><td></td><td>23</td><td>22</td><td>21</td><td>20</td><td></td><td></td><td></td><td>17</td><td></td></tr> <tr><td></td><td></td><td></td><td></td><td>15</td><td>14</td><td>13</td><td></td><td></td><td></td><td></td><td></td><td>7</td><td>6</td><td>5</td><td>4</td><td></td><td></td><td></td><td></td><td>1</td></tr> </table>	72	70	68						63	62			59	58	57					53	52	51		48	47			44	42	40	39									34	33				32		30			26	25			23	22	21	20				17						15	14	13						7	6	5	4					1
72	70	68						63	62			59	58	57					53																																																																							
52	51		48	47			44	42	40	39									34	33																																																																						
			32		30			26	25			23	22	21	20				17																																																																							
				15	14	13						7	6	5	4					1																																																																						
AVAILABLE	NOT APPLICABLE	34566-4363	G	0	A	BLACK	<table border="1"> <tr><td></td><td>70</td><td>69</td><td></td><td></td><td></td><td></td><td></td><td>63</td><td>62</td><td>61</td><td>60</td><td></td><td></td><td>58</td><td>57</td><td>56</td><td>55</td><td>54</td><td>53</td></tr> <tr><td>52</td><td>51</td><td>49</td><td></td><td></td><td></td><td></td><td></td><td>44</td><td>43</td><td>42</td><td>41</td><td></td><td></td><td></td><td>37</td><td>36</td><td></td><td>34</td><td></td></tr> <tr><td></td><td></td><td></td><td>32</td><td></td><td></td><td></td><td></td><td>29</td><td>28</td><td>27</td><td>26</td><td></td><td></td><td>23</td><td></td><td></td><td></td><td></td><td>19</td><td>18</td></tr> <tr><td></td><td></td><td></td><td>16</td><td>15</td><td></td><td></td><td></td><td>13</td><td>12</td><td>11</td><td>10</td><td></td><td></td><td>8</td><td></td><td></td><td></td><td></td><td>3</td><td></td></tr> </table>		70	69						63	62	61	60			58	57	56	55	54	53	52	51	49						44	43	42	41				37	36		34					32					29	28	27	26			23					19	18				16	15				13	12	11	10			8					3		
	70	69						63	62	61	60			58	57	56	55	54	53																																																																							
52	51	49						44	43	42	41				37	36		34																																																																								
			32					29	28	27	26			23					19	18																																																																						
			16	15				13	12	11	10			8					3																																																																							
AVAILABLE	NOT APPLICABLE	34566-4373	G	0	A	BLACK	<table border="1"> <tr><td></td><td>70</td><td>69</td><td></td><td></td><td></td><td></td><td></td><td>63</td><td></td><td></td><td></td><td></td><td></td><td>58</td><td></td><td>56</td><td></td><td>54</td><td></td></tr> <tr><td>52</td><td>51</td><td>49</td><td></td><td></td><td>47</td><td></td><td></td><td>44</td><td>43</td><td>42</td><td>41</td><td>40</td><td></td><td></td><td></td><td></td><td></td><td>36</td><td>34</td></tr> <tr><td></td><td></td><td></td><td>32</td><td></td><td></td><td></td><td></td><td>28</td><td></td><td>26</td><td></td><td></td><td></td><td></td><td></td><td></td><td></td><td></td><td>19</td><td>18</td></tr> <tr><td></td><td></td><td></td><td>16</td><td></td><td></td><td></td><td></td><td>12</td><td></td><td>10</td><td></td><td></td><td></td><td></td><td></td><td></td><td></td><td></td><td>3</td><td>2</td><td>1</td></tr> </table>		70	69						63						58		56		54		52	51	49			47			44	43	42	41	40						36	34				32					28		26									19	18				16					12		10									3	2	1
	70	69						63						58		56		54																																																																								
52	51	49			47			44	43	42	41	40						36	34																																																																							
			32					28		26									19	18																																																																						
			16					12		10									3	2	1																																																																					

ENTER DESCRIPTION IEC NO: UAU2014-0376 DRAWN BY: 2013/09/05 CHKO: 2013/09/06 APPR: IKOSHY REV: DESCRIPTION	QUALITY SYMBOLS	GENERAL TOLERANCES (UNLESS SPECIFIED)	DIMENSION STYLE	SCALE	DESIGN UNITS	THIRD ANGLE PROJECTION	
	$\nabla=0$ $\nabla=0$ $\nabla=0$	mm INCH 4 PLACES ± --- ± --- 3 PLACES ± --- ± --- 2 PLACES ± --- ± --- 1 PLACE ± --- ± --- 0 PLACE ± --- ± ---	MM ONLY	MM ONLY	METRIC	SKRA JENDRANA 2011/02/14 MVANSLAMBROU 2011/02/14	MX123 66/73/80CKT HRNS CONN ASSY
	ANGULAR ± ---° DRAFT WHERE APPLICABLE MUST REMAIN WITHIN DIMENSIONS	MATERIAL NO. SEE BOM TABLE	DATE DATE DATE	DOCUMENT NO. SD-34566-001	SHEET NO. 50 OF 68	THIS DRAWING CONTAINS INFORMATION THAT IS PROPRIETARY TO MOLEX INCORPORATED AND SHOULD NOT BE USED WITHOUT WRITTEN PERMISSION	molex

STATUS	GM PART #	MATERIAL #	PART/MATERIAL REVISION	WIRE DRESS OPTION	KEY OPTION	COLOR (TPA)	NUMBERS INDICATE CAVITIES OPEN FOR CIRCUITS																																																																													
AVAILABLE	NOT APPLICABLE	34566-4383	G	0	H	ST GRAY	<table border="1"> <tr><td>79</td><td></td><td></td><td></td><td>74</td><td>73</td><td>72</td><td>71</td><td>69</td><td>68</td><td>67</td><td></td><td>64</td><td>62</td><td>61</td></tr> <tr><td>59</td><td></td><td></td><td></td><td>54</td><td>52</td><td></td><td></td><td>49</td><td>48</td><td>47</td><td></td><td></td><td>42</td><td>41</td></tr> <tr><td></td><td>38</td><td></td><td></td><td></td><td>33</td><td></td><td></td><td>29</td><td>27</td><td>25</td><td></td><td></td><td></td><td></td></tr> <tr><td></td><td>18</td><td></td><td>15</td><td>14</td><td></td><td></td><td>11</td><td>10</td><td>9</td><td>8</td><td>7</td><td></td><td></td><td></td></tr> </table>	79				74	73	72	71	69	68	67		64	62	61	59				54	52			49	48	47			42	41		38				33			29	27	25						18		15	14			11	10	9	8	7																				
79				74	73	72	71	69	68	67		64	62	61																																																																						
59				54	52			49	48	47			42	41																																																																						
	38				33			29	27	25																																																																										
	18		15	14			11	10	9	8	7																																																																									
AVAILABLE	NOT APPLICABLE	34566-4393	G	0	G	BLUE	<table border="1"> <tr><td></td><td>78</td><td>77</td><td>75</td><td>74</td><td>72</td><td>70</td><td>69</td><td>67</td><td>65</td><td>64</td><td>63</td><td>62</td><td></td><td></td></tr> <tr><td>60</td><td>58</td><td>57</td><td>55</td><td>54</td><td>52</td><td>51</td><td>50</td><td>49</td><td>47</td><td>45</td><td></td><td></td><td></td><td></td></tr> <tr><td>40</td><td>38</td><td>37</td><td></td><td></td><td>33</td><td>32</td><td>31</td><td></td><td>27</td><td>26</td><td>25</td><td>24</td><td></td><td></td></tr> <tr><td>20</td><td>18</td><td>17</td><td></td><td></td><td></td><td></td><td>10</td><td>9</td><td>8</td><td>7</td><td>6</td><td>5</td><td>3</td><td>2</td><td>1</td></tr> </table>		78	77	75	74	72	70	69	67	65	64	63	62			60	58	57	55	54	52	51	50	49	47	45					40	38	37			33	32	31		27	26	25	24			20	18	17					10	9	8	7	6	5	3	2	1																
	78	77	75	74	72	70	69	67	65	64	63	62																																																																								
60	58	57	55	54	52	51	50	49	47	45																																																																										
40	38	37			33	32	31		27	26	25	24																																																																								
20	18	17					10	9	8	7	6	5	3	2	1																																																																					
AVAILABLE	NOT APPLICABLE	34566-4413	G	0	B	ST GRAY	<table border="1"> <tr><td></td><td></td><td></td><td></td><td></td><td></td><td>63</td><td></td><td>59</td><td>58</td><td>57</td><td>56</td><td>55</td><td>53</td><td></td></tr> <tr><td></td><td>50</td><td>49</td><td>48</td><td></td><td>46</td><td></td><td>43</td><td></td><td>39</td><td>38</td><td>37</td><td>36</td><td>35</td><td>34</td><td>33</td></tr> <tr><td></td><td>73</td><td></td><td></td><td></td><td>29</td><td>27</td><td></td><td>23</td><td>22</td><td>21</td><td></td><td></td><td>18</td><td></td></tr> <tr><td></td><td></td><td></td><td>16</td><td>15</td><td>14</td><td></td><td></td><td>7</td><td>6</td><td>5</td><td>4</td><td>3</td><td></td><td></td></tr> </table>							63		59	58	57	56	55	53			50	49	48		46		43		39	38	37	36	35	34	33		73				29	27		23	22	21			18					16	15	14			7	6	5	4	3																		
						63		59	58	57	56	55	53																																																																							
	50	49	48		46		43		39	38	37	36	35	34	33																																																																					
	73				29	27		23	22	21			18																																																																							
			16	15	14			7	6	5	4	3																																																																								
AVAILABLE	NOT APPLICABLE	34566-4423	G	9	C	BLUE	<table border="1"> <tr><td>72</td><td>70</td><td>68</td><td>67</td><td>66</td><td></td><td>63</td><td>62</td><td></td><td>59</td><td>57</td><td></td><td></td><td>53</td><td></td></tr> <tr><td>52</td><td>51</td><td></td><td>48</td><td>47</td><td>46</td><td>44</td><td>42</td><td>40</td><td>39</td><td>38</td><td>37</td><td>36</td><td></td><td>34</td><td>33</td></tr> <tr><td></td><td></td><td></td><td>32</td><td>30</td><td></td><td>27</td><td>26</td><td>25</td><td>24</td><td>22</td><td>21</td><td></td><td></td><td></td><td></td></tr> <tr><td></td><td>73</td><td></td><td></td><td>15</td><td>14</td><td></td><td></td><td>10</td><td>9</td><td>8</td><td>7</td><td>6</td><td>5</td><td>4</td><td>2</td></tr> </table>	72	70	68	67	66		63	62		59	57			53		52	51		48	47	46	44	42	40	39	38	37	36		34	33				32	30		27	26	25	24	22	21						73			15	14			10	9	8	7	6	5	4	2														
72	70	68	67	66		63	62		59	57			53																																																																							
52	51		48	47	46	44	42	40	39	38	37	36		34	33																																																																					
			32	30		27	26	25	24	22	21																																																																									
	73			15	14			10	9	8	7	6	5	4	2																																																																					
AVAILABLE	NOT APPLICABLE	34566-4433	G	9	A	BLACK	<table border="1"> <tr><td></td><td>70</td><td>69</td><td></td><td></td><td></td><td>63</td><td>62</td><td>61</td><td>60</td><td>58</td><td>57</td><td>56</td><td>55</td><td>54</td><td>53</td></tr> <tr><td>52</td><td>51</td><td>50</td><td>49</td><td></td><td></td><td>44</td><td>43</td><td>42</td><td>41</td><td>40</td><td></td><td>37</td><td>36</td><td></td><td>34</td></tr> <tr><td></td><td></td><td></td><td></td><td></td><td></td><td>29</td><td>28</td><td>27</td><td>26</td><td></td><td></td><td></td><td></td><td>19</td><td>18</td></tr> <tr><td></td><td>73</td><td></td><td></td><td>16</td><td>15</td><td>14</td><td>13</td><td>12</td><td>11</td><td>10</td><td></td><td></td><td></td><td>3</td><td></td></tr> </table>		70	69				63	62	61	60	58	57	56	55	54	53	52	51	50	49			44	43	42	41	40		37	36		34							29	28	27	26					19	18		73			16	15	14	13	12	11	10				3														
	70	69				63	62	61	60	58	57	56	55	54	53																																																																					
52	51	50	49			44	43	42	41	40		37	36		34																																																																					
						29	28	27	26					19	18																																																																					
	73			16	15	14	13	12	11	10				3																																																																						
AVAILABLE	NOT APPLICABLE	34566-4443	G	9	A	BLACK	<table border="1"> <tr><td></td><td></td><td></td><td></td><td>67</td><td>66</td><td></td><td></td><td></td><td></td><td></td><td></td><td></td><td></td><td></td><td></td></tr> <tr><td></td><td></td><td></td><td>48</td><td>47</td><td></td><td></td><td></td><td>41</td><td></td><td></td><td></td><td></td><td></td><td></td><td></td></tr> <tr><td></td><td></td><td></td><td>32</td><td>31</td><td>30</td><td>29</td><td></td><td>27</td><td>26</td><td>25</td><td></td><td></td><td></td><td>19</td><td>18</td><td>17</td></tr> <tr><td></td><td></td><td></td><td>16</td><td>15</td><td>14</td><td>13</td><td></td><td>11</td><td>10</td><td>9</td><td>8</td><td>7</td><td>6</td><td>5</td><td>4</td><td>3</td><td>1</td></tr> </table>					67	66														48	47				41											32	31	30	29		27	26	25				19	18	17				16	15	14	13		11	10	9	8	7	6	5	4	3	1										
				67	66																																																																															
			48	47				41																																																																												
			32	31	30	29		27	26	25				19	18	17																																																																				
			16	15	14	13		11	10	9	8	7	6	5	4	3	1																																																																			
AVAILABLE	NOT APPLICABLE	34566-4453	G	0	A	BLACK	<table border="1"> <tr><td>72</td><td>71</td><td>70</td><td>69</td><td>68</td><td></td><td>65</td><td>64</td><td>63</td><td>62</td><td>61</td><td>60</td><td>59</td><td>58</td><td>57</td><td>56</td><td>55</td><td>54</td><td>53</td></tr> <tr><td>52</td><td>51</td><td>50</td><td>49</td><td>48</td><td></td><td>46</td><td>45</td><td>44</td><td>43</td><td>42</td><td>40</td><td>39</td><td>38</td><td>37</td><td>36</td><td>35</td><td>34</td><td>33</td></tr> <tr><td></td><td></td><td></td><td></td><td></td><td></td><td></td><td></td><td>28</td><td></td><td></td><td>24</td><td>23</td><td></td><td>20</td><td></td><td></td><td></td><td></td></tr> <tr><td></td><td></td><td></td><td></td><td></td><td></td><td></td><td></td><td>12</td><td>11</td><td></td><td></td><td></td><td></td><td></td><td></td><td></td><td>2</td><td>1</td></tr> </table>	72	71	70	69	68		65	64	63	62	61	60	59	58	57	56	55	54	53	52	51	50	49	48		46	45	44	43	42	40	39	38	37	36	35	34	33									28			24	23		20													12	11								2	1	
72	71	70	69	68		65	64	63	62	61	60	59	58	57	56	55	54	53																																																																		
52	51	50	49	48		46	45	44	43	42	40	39	38	37	36	35	34	33																																																																		
								28			24	23		20																																																																						
								12	11								2	1																																																																		
AVAILABLE	NOT APPLICABLE	34566-4463	G	9	B	ST GRAY	<table border="1"> <tr><td></td><td></td><td></td><td></td><td></td><td></td><td>63</td><td></td><td></td><td></td><td></td><td></td><td></td><td></td><td></td><td></td><td></td><td></td><td>53</td></tr> <tr><td></td><td></td><td></td><td></td><td></td><td></td><td>48</td><td>47</td><td>45</td><td>43</td><td>42</td><td></td><td>39</td><td></td><td></td><td></td><td></td><td>35</td><td>34</td><td>33</td></tr> <tr><td></td><td></td><td></td><td></td><td></td><td></td><td></td><td></td><td></td><td></td><td></td><td></td><td>23</td><td>22</td><td></td><td></td><td></td><td>19</td><td></td></tr> <tr><td></td><td></td><td></td><td></td><td></td><td></td><td></td><td></td><td></td><td>11</td><td></td><td></td><td></td><td></td><td></td><td></td><td></td><td></td><td>1</td></tr> </table>							63												53							48	47	45	43	42		39					35	34	33													23	22				19											11									1
						63												53																																																																		
						48	47	45	43	42		39					35	34	33																																																																	
												23	22				19																																																																			
									11									1																																																																		
AVAILABLE	NOT APPLICABLE	34566-4473	G	0	B	ST GRAY	<table border="1"> <tr><td></td><td></td><td></td><td></td><td></td><td></td><td>64</td><td>63</td><td>62</td><td></td><td>59</td><td>58</td><td></td><td></td><td></td><td></td><td></td><td></td><td>53</td></tr> <tr><td></td><td></td><td></td><td></td><td></td><td></td><td>47</td><td>45</td><td>43</td><td>42</td><td></td><td>39</td><td></td><td></td><td></td><td></td><td></td><td>35</td><td>34</td><td>33</td></tr> <tr><td></td><td></td><td></td><td></td><td></td><td></td><td></td><td></td><td></td><td>26</td><td>25</td><td>23</td><td>22</td><td></td><td></td><td></td><td></td><td>3</td><td></td><td>1</td></tr> </table>							64	63	62		59	58							53							47	45	43	42		39						35	34	33										26	25	23	22					3		1																		
						64	63	62		59	58							53																																																																		
						47	45	43	42		39						35	34	33																																																																	
									26	25	23	22					3		1																																																																	

ENTER DESCRIPTION IEC NO: UAU2014-0376 DRAWN BY: CHYD CHKD: APPR: IKOSHY 2013/09/05 2013/09/06	QUALITY SYMBOLS	GENERAL TOLERANCES (UNLESS SPECIFIED)	DIMENSION STYLE	SCALE	DESIGN UNITS	THIRD ANGLE PROJECTION	
	∇=0 ∇=0 ∇=0	mm INCH 4 PLACES ± --- ± --- 3 PLACES ± --- ± --- 2 PLACES ± --- ± --- 1 PLACE ± --- ± --- 0 PLACE ± --- ± ---	MM ONLY	MM ONLY	METRIC	SKRA JENDRANA 2011/02/14 MYANSLAMBROU 2011/02/14	MX123 66/73/80CKT HRNS CONN ASSY molex
	ANGULAR ± ---° DRAFT WHERE APPLICABLE MUST REMAIN WITHIN DIMENSIONS	MATERIAL NO. SEE BOM TABLE	DATE DATE DATE	DOCUMENT NO. SD-34566-001	SHEET NO. 51 OF 68		
	THIS DRAWING CONTAINS INFORMATION THAT IS PROPRIETARY TO MOLEX INCORPORATED AND SHOULD NOT BE USED WITHOUT WRITTEN PERMISSION						

STATUS	GM PART #	MATERIAL #	PART/MATERIAL REVISION	WIRE DRESS OPTION	KEY OPTION	COLOR (TPA)	NUMBERS INDICATE CAVITIES OPEN FOR CIRCUITS																																																																								
AVAILABLE	NOT APPLICABLE	34566-4483	G	9	C	BLUE	<table border="1"> <tr><td>72</td><td>70</td><td>68</td><td>67</td><td>66</td><td></td><td>63</td><td>62</td><td></td><td>59</td><td>58</td><td>57</td><td>56</td><td>55</td><td>53</td></tr> <tr><td>52</td><td>51</td><td>49</td><td>48</td><td>47</td><td>46</td><td>44</td><td></td><td></td><td>40</td><td>39</td><td>38</td><td>37</td><td>36</td><td>34</td><td>33</td></tr> <tr><td colspan="2">73</td><td>32</td><td>30</td><td></td><td></td><td>27</td><td>26</td><td>25</td><td>24</td><td>23</td><td>22</td><td>21</td><td>20</td><td>19</td><td>18</td><td>17</td></tr> <tr><td></td><td></td><td>15</td><td>14</td><td>13</td><td></td><td>10</td><td>9</td><td>8</td><td>7</td><td>6</td><td>5</td><td>4</td><td>3</td><td>2</td><td>1</td><td></td></tr> </table>	72	70	68	67	66		63	62		59	58	57	56	55	53	52	51	49	48	47	46	44			40	39	38	37	36	34	33	73		32	30			27	26	25	24	23	22	21	20	19	18	17			15	14	13		10	9	8	7	6	5	4	3	2	1								
72	70	68	67	66		63	62		59	58	57	56	55	53																																																																	
52	51	49	48	47	46	44			40	39	38	37	36	34	33																																																																
73		32	30			27	26	25	24	23	22	21	20	19	18	17																																																															
		15	14	13		10	9	8	7	6	5	4	3	2	1																																																																
AVAILABLE	NOT APPLICABLE	34566-4493	G	9	A	BLACK	<table border="1"> <tr><td>72</td><td>71</td><td>70</td><td>69</td><td>67</td><td></td><td>64</td><td>63</td><td>62</td><td>61</td><td>60</td><td>59</td><td>58</td><td>57</td><td>56</td><td>55</td><td>54</td><td>53</td></tr> <tr><td>52</td><td>51</td><td>50</td><td>49</td><td>48</td><td>47</td><td>45</td><td>44</td><td>43</td><td>42</td><td>41</td><td>40</td><td>39</td><td>38</td><td>37</td><td>36</td><td>34</td><td>33</td></tr> <tr><td colspan="2">73</td><td>32</td><td>30</td><td>29</td><td>28</td><td>27</td><td>26</td><td></td><td>24</td><td>23</td><td></td><td>21</td><td></td><td>19</td><td>18</td><td>17</td></tr> <tr><td></td><td></td><td>16</td><td>15</td><td>14</td><td>13</td><td>12</td><td>11</td><td>10</td><td>8</td><td></td><td></td><td>5</td><td></td><td>3</td><td>2</td><td>1</td><td></td></tr> </table>	72	71	70	69	67		64	63	62	61	60	59	58	57	56	55	54	53	52	51	50	49	48	47	45	44	43	42	41	40	39	38	37	36	34	33	73		32	30	29	28	27	26		24	23		21		19	18	17			16	15	14	13	12	11	10	8			5		3	2	1		
72	71	70	69	67		64	63	62	61	60	59	58	57	56	55	54	53																																																														
52	51	50	49	48	47	45	44	43	42	41	40	39	38	37	36	34	33																																																														
73		32	30	29	28	27	26		24	23		21		19	18	17																																																															
		16	15	14	13	12	11	10	8			5		3	2	1																																																															
AVAILABLE	NOT APPLICABLE	34566-4513	G	9	B	ST GRY	<table border="1"> <tr><td>72</td><td>71</td><td>70</td><td>68</td><td>67</td><td>66</td><td></td><td></td><td>62</td><td>61</td><td>60</td><td>59</td><td>58</td><td>57</td><td>56</td><td>55</td><td>54</td><td>53</td></tr> <tr><td>52</td><td>51</td><td>50</td><td>48</td><td>47</td><td>46</td><td></td><td></td><td>42</td><td>41</td><td>40</td><td>39</td><td>38</td><td>37</td><td>36</td><td>35</td><td>34</td><td>33</td></tr> <tr><td colspan="2">73</td><td>32</td><td>31</td><td>30</td><td>29</td><td>28</td><td>27</td><td>26</td><td>25</td><td>24</td><td>23</td><td></td><td></td><td>19</td><td>18</td><td>17</td></tr> <tr><td></td><td></td><td>16</td><td>15</td><td>14</td><td>13</td><td></td><td></td><td>10</td><td>8</td><td>7</td><td></td><td></td><td></td><td>3</td><td>2</td><td>1</td><td></td></tr> </table>	72	71	70	68	67	66			62	61	60	59	58	57	56	55	54	53	52	51	50	48	47	46			42	41	40	39	38	37	36	35	34	33	73		32	31	30	29	28	27	26	25	24	23			19	18	17			16	15	14	13			10	8	7				3	2	1		
72	71	70	68	67	66			62	61	60	59	58	57	56	55	54	53																																																														
52	51	50	48	47	46			42	41	40	39	38	37	36	35	34	33																																																														
73		32	31	30	29	28	27	26	25	24	23			19	18	17																																																															
		16	15	14	13			10	8	7				3	2	1																																																															
AVAILABLE	NOT APPLICABLE	34566-4523	G	0	G	BLUE	<table border="1"> <tr><td></td><td>78</td><td>77</td><td>75</td><td>74</td><td>72</td><td>70</td><td>69</td><td>67</td><td>66</td><td>65</td><td>64</td><td>63</td><td>62</td><td></td><td></td><td></td><td></td></tr> <tr><td>60</td><td>58</td><td>57</td><td>55</td><td>54</td><td>52</td><td>51</td><td>50</td><td>49</td><td>47</td><td>45</td><td></td><td></td><td></td><td></td><td></td><td></td><td></td></tr> <tr><td>40</td><td>38</td><td>37</td><td></td><td></td><td></td><td>31</td><td></td><td></td><td>27</td><td>26</td><td>25</td><td>24</td><td></td><td></td><td></td><td></td><td></td></tr> <tr><td>20</td><td>18</td><td>17</td><td></td><td></td><td></td><td></td><td>10</td><td>9</td><td>8</td><td>6</td><td>5</td><td></td><td></td><td>3</td><td>2</td><td>1</td><td></td></tr> </table>		78	77	75	74	72	70	69	67	66	65	64	63	62					60	58	57	55	54	52	51	50	49	47	45								40	38	37				31			27	26	25	24						20	18	17					10	9	8	6	5			3	2	1	
	78	77	75	74	72	70	69	67	66	65	64	63	62																																																																		
60	58	57	55	54	52	51	50	49	47	45																																																																					
40	38	37				31			27	26	25	24																																																																			
20	18	17					10	9	8	6	5			3	2	1																																																															
AVAILABLE	NOT APPLICABLE	34566-4533	G	0	A	BLACK	<table border="1"> <tr><td>72</td><td></td><td>69</td><td>67</td><td>65</td><td>63</td><td></td><td>60</td><td></td><td>57</td><td>56</td><td></td><td></td><td></td><td></td><td></td><td></td><td>53</td></tr> <tr><td></td><td></td><td>49</td><td>47</td><td>44</td><td>43</td><td></td><td>40</td><td></td><td>37</td><td>36</td><td>35</td><td>34</td><td>33</td><td></td><td></td><td></td><td></td></tr> <tr><td colspan="2">73</td><td></td><td>31</td><td>30</td><td>29</td><td>28</td><td></td><td>24</td><td></td><td>21</td><td>20</td><td></td><td></td><td></td><td></td><td></td><td></td></tr> <tr><td></td><td></td><td>16</td><td>15</td><td>14</td><td>13</td><td>11</td><td>10</td><td></td><td></td><td></td><td>5</td><td>4</td><td>3</td><td>2</td><td>1</td><td></td><td></td></tr> </table>	72		69	67	65	63		60		57	56							53			49	47	44	43		40		37	36	35	34	33					73			31	30	29	28		24		21	20									16	15	14	13	11	10				5	4	3	2	1		
72		69	67	65	63		60		57	56							53																																																														
		49	47	44	43		40		37	36	35	34	33																																																																		
73			31	30	29	28		24		21	20																																																																				
		16	15	14	13	11	10				5	4	3	2	1																																																																
AVAILABLE	NOT APPLICABLE	34566-4543	G	0	B	ST GRY	<table border="1"> <tr><td></td><td></td><td></td><td>68</td><td>67</td><td></td><td>64</td><td>63</td><td></td><td></td><td></td><td>58</td><td>57</td><td>55</td><td>53</td><td></td><td></td><td></td></tr> <tr><td></td><td></td><td></td><td>46</td><td>45</td><td>43</td><td></td><td></td><td></td><td></td><td></td><td>38</td><td>37</td><td>35</td><td></td><td></td><td></td><td></td></tr> <tr><td colspan="2">73</td><td></td><td>32</td><td>30</td><td>29</td><td>28</td><td>27</td><td></td><td></td><td></td><td>22</td><td>21</td><td>19</td><td>17</td><td></td><td></td><td></td></tr> <tr><td></td><td></td><td></td><td></td><td></td><td></td><td>12</td><td>10</td><td></td><td></td><td></td><td></td><td></td><td></td><td></td><td></td><td></td><td>1</td></tr> </table>				68	67		64	63				58	57	55	53							46	45	43						38	37	35					73			32	30	29	28	27				22	21	19	17										12	10										1
			68	67		64	63				58	57	55	53																																																																	
			46	45	43						38	37	35																																																																		
73			32	30	29	28	27				22	21	19	17																																																																	
						12	10										1																																																														
AVAILABLE	NOT APPLICABLE	34566-4553	G	0	B	ST GRY	<table border="1"> <tr><td></td><td></td><td></td><td>68</td><td>67</td><td></td><td>64</td><td>63</td><td></td><td></td><td></td><td>58</td><td>57</td><td></td><td>53</td><td></td><td></td><td></td></tr> <tr><td></td><td></td><td></td><td>46</td><td>45</td><td>43</td><td></td><td></td><td></td><td></td><td></td><td>38</td><td>37</td><td></td><td></td><td></td><td></td><td></td></tr> <tr><td colspan="2">73</td><td></td><td>32</td><td>30</td><td>29</td><td>28</td><td>27</td><td></td><td></td><td></td><td>22</td><td>21</td><td></td><td>17</td><td></td><td></td><td></td></tr> <tr><td></td><td></td><td></td><td></td><td></td><td></td><td>12</td><td>10</td><td></td><td></td><td></td><td></td><td></td><td></td><td></td><td></td><td></td><td></td></tr> </table>				68	67		64	63				58	57		53							46	45	43						38	37						73			32	30	29	28	27				22	21		17										12	10										
			68	67		64	63				58	57		53																																																																	
			46	45	43						38	37																																																																			
73			32	30	29	28	27				22	21		17																																																																	
						12	10																																																																								
AVAILABLE	NOT APPLICABLE	34566-4563	G	0	B	ST GRY	<table border="1"> <tr><td></td><td></td><td></td><td>68</td><td>67</td><td></td><td>64</td><td>63</td><td></td><td></td><td></td><td>58</td><td></td><td>55</td><td>53</td><td></td><td></td><td></td></tr> <tr><td></td><td></td><td></td><td>46</td><td>45</td><td>43</td><td></td><td></td><td></td><td></td><td></td><td>38</td><td></td><td>35</td><td></td><td></td><td></td><td></td></tr> <tr><td colspan="2">73</td><td></td><td>32</td><td>30</td><td>29</td><td>28</td><td>27</td><td></td><td>10</td><td></td><td>22</td><td></td><td>19</td><td>17</td><td></td><td></td><td></td></tr> <tr><td></td><td></td><td></td><td></td><td></td><td></td><td>12</td><td>10</td><td></td><td></td><td></td><td></td><td></td><td></td><td></td><td></td><td></td><td>1</td></tr> </table>				68	67		64	63				58		55	53							46	45	43						38		35					73			32	30	29	28	27		10		22		19	17										12	10										1
			68	67		64	63				58		55	53																																																																	
			46	45	43						38		35																																																																		
73			32	30	29	28	27		10		22		19	17																																																																	
						12	10										1																																																														
AVAILABLE	NOT APPLICABLE	34566-4573	G	0	B	ST GRY	<table border="1"> <tr><td></td><td></td><td></td><td>68</td><td>67</td><td></td><td>64</td><td>63</td><td></td><td></td><td></td><td>58</td><td></td><td></td><td>53</td><td></td><td></td><td></td></tr> <tr><td></td><td></td><td></td><td>46</td><td>45</td><td>43</td><td></td><td></td><td></td><td></td><td></td><td>38</td><td></td><td></td><td></td><td></td><td></td><td></td></tr> <tr><td colspan="2">73</td><td></td><td>32</td><td>30</td><td>29</td><td>28</td><td>27</td><td></td><td></td><td></td><td>22</td><td></td><td></td><td>17</td><td></td><td></td><td></td></tr> <tr><td></td><td></td><td></td><td></td><td></td><td></td><td>12</td><td>10</td><td></td><td></td><td></td><td></td><td></td><td></td><td></td><td></td><td></td><td></td></tr> </table>				68	67		64	63				58			53							46	45	43						38							73			32	30	29	28	27				22			17										12	10										
			68	67		64	63				58			53																																																																	
			46	45	43						38																																																																				
73			32	30	29	28	27				22			17																																																																	
						12	10																																																																								

ENTER DESCRIPTION ELEC NO: UAU2014-0376 DRAWN BY: 2013/09/05 CHKD: 2013/09/06 APPR: IKOSHY	QUALITY SYMBOLS ∇=0 ∇=0 ∇=0	GENERAL TOLERANCES (UNLESS SPECIFIED) DIMENSION STYLE MM ONLY	SCALE DESIGN UNITS METRIC	THIRD ANGLE PROJECTION	
	4 PLACES ±--- ±--- 3 PLACES ±--- ±--- 2 PLACES ±--- ±--- 1 PLACE ±--- ±--- 0 PLACE ±--- ±---	DIMENSION STYLE DRAWN BY: SKRAJENDRANA 2011/02/14 CHECKED BY: MYANSLAMBROU 2011/02/14 APPROVED BY:	TITLE MX123 66/73/80CKT HRNS CONN ASSY	MATERIAL NO. SD-34566-001	SHEET NO. 52 OF 68
	ANGULAR ±---° DRAFT WHERE APPLICABLE MUST REMAIN WITHIN DIMENSIONS	SEE BOM TABLE	DOCUMENT NO.	INCORPORATED AND SHOULD NOT BE USED WITHOUT WRITTEN PERMISSION	THIS DRAWING CONTAINS INFORMATION THAT IS PROPRIETARY TO MOLEX
	SIZE D	INCORPORATED AND SHOULD NOT BE USED WITHOUT WRITTEN PERMISSION	INCORPORATED AND SHOULD NOT BE USED WITHOUT WRITTEN PERMISSION	INCORPORATED AND SHOULD NOT BE USED WITHOUT WRITTEN PERMISSION	INCORPORATED AND SHOULD NOT BE USED WITHOUT WRITTEN PERMISSION

STATUS	GM PART #	MATERIAL #	PART/MATERIAL REVISION	WIRE DRESS OPTION	KEY OPTION	COLOR (TPA)	NUMBERS INDICATE CAVITIES OPEN FOR CIRCUITS																																																																																		
AVAILABLE	NOT APPLICABLE	34566-4683	G	9	B	ST GRAY	<table border="1"> <tr><td>72</td><td>71</td><td>70</td><td>69</td><td>68</td><td>67</td><td>66</td><td>65</td><td>64</td><td></td><td>62</td><td>61</td><td>60</td><td>59</td><td>58</td><td>57</td><td>56</td><td>55</td><td>54</td></tr> <tr><td>52</td><td>51</td><td>50</td><td>49</td><td></td><td></td><td>46</td><td>44</td><td></td><td></td><td></td><td>41</td><td>40</td><td></td><td>38</td><td>37</td><td>36</td><td></td><td></td></tr> <tr><td></td><td></td><td></td><td></td><td>73</td><td></td><td>32</td><td>31</td><td>30</td><td>29</td><td>28</td><td>27</td><td>25</td><td>24</td><td></td><td>21</td><td>20</td><td></td><td>18</td><td>17</td></tr> <tr><td></td><td></td><td></td><td></td><td></td><td></td><td>16</td><td>15</td><td>14</td><td>13</td><td>12</td><td></td><td>10</td><td>9</td><td>8</td><td>7</td><td>6</td><td>5</td><td>4</td><td>3</td><td>2</td></tr> </table>	72	71	70	69	68	67	66	65	64		62	61	60	59	58	57	56	55	54	52	51	50	49			46	44				41	40		38	37	36							73		32	31	30	29	28	27	25	24		21	20		18	17							16	15	14	13	12		10	9	8	7	6	5	4	3	2			
72	71	70	69	68	67	66	65	64		62	61	60	59	58	57	56	55	54																																																																							
52	51	50	49			46	44				41	40		38	37	36																																																																									
				73		32	31	30	29	28	27	25	24		21	20		18	17																																																																						
						16	15	14	13	12		10	9	8	7	6	5	4	3	2																																																																					
AVAILABLE	NOT APPLICABLE	34566-4693	G	0	B	ST GRAY	<table border="1"> <tr><td>72</td><td>71</td><td>70</td><td>69</td><td>68</td><td>67</td><td>66</td><td>65</td><td></td><td></td><td>61</td><td>60</td><td></td><td></td><td>57</td><td>56</td><td>55</td><td>54</td><td></td><td></td></tr> <tr><td>52</td><td>51</td><td>50</td><td>49</td><td>48</td><td></td><td>46</td><td>44</td><td></td><td></td><td></td><td>41</td><td>40</td><td></td><td>38</td><td>37</td><td>36</td><td></td><td></td><td></td></tr> <tr><td></td><td></td><td></td><td></td><td>73</td><td></td><td>32</td><td>31</td><td>30</td><td>29</td><td>28</td><td>27</td><td></td><td>24</td><td></td><td>21</td><td>20</td><td>19</td><td>18</td><td>17</td></tr> <tr><td></td><td></td><td></td><td></td><td></td><td></td><td>16</td><td>15</td><td>14</td><td>13</td><td>12</td><td>11</td><td>10</td><td>9</td><td>8</td><td>7</td><td>6</td><td>5</td><td>4</td><td>3</td><td>2</td></tr> </table>	72	71	70	69	68	67	66	65			61	60			57	56	55	54			52	51	50	49	48		46	44				41	40		38	37	36								73		32	31	30	29	28	27		24		21	20	19	18	17							16	15	14	13	12	11	10	9	8	7	6	5	4	3	2	
72	71	70	69	68	67	66	65			61	60			57	56	55	54																																																																								
52	51	50	49	48		46	44				41	40		38	37	36																																																																									
				73		32	31	30	29	28	27		24		21	20	19	18	17																																																																						
						16	15	14	13	12	11	10	9	8	7	6	5	4	3	2																																																																					
AVAILABLE	NOT APPLICABLE	34566-4713	G	0	A	BLACK	<table border="1"> <tr><td>72</td><td>71</td><td>70</td><td>69</td><td></td><td>67</td><td></td><td></td><td>64</td><td>63</td><td></td><td></td><td>60</td><td>59</td><td></td><td></td><td>56</td><td>55</td><td>54</td><td>53</td></tr> <tr><td>52</td><td>51</td><td></td><td>49</td><td></td><td>47</td><td></td><td>45</td><td>44</td><td>43</td><td>42</td><td>41</td><td></td><td></td><td></td><td></td><td>36</td><td></td><td>34</td><td></td></tr> <tr><td></td><td></td><td></td><td></td><td>73</td><td></td><td>32</td><td></td><td>30</td><td></td><td>28</td><td>26</td><td></td><td></td><td>23</td><td></td><td></td><td></td><td>19</td><td>18</td></tr> <tr><td></td><td></td><td></td><td></td><td></td><td></td><td>16</td><td>15</td><td></td><td></td><td>12</td><td>10</td><td></td><td></td><td></td><td></td><td></td><td></td><td>3</td><td></td></tr> </table>	72	71	70	69		67			64	63			60	59			56	55	54	53	52	51		49		47		45	44	43	42	41					36		34						73		32		30		28	26			23				19	18							16	15			12	10							3			
72	71	70	69		67			64	63			60	59			56	55	54	53																																																																						
52	51		49		47		45	44	43	42	41					36		34																																																																							
				73		32		30		28	26			23				19	18																																																																						
						16	15			12	10							3																																																																							
AVAILABLE	NOT APPLICABLE	34566-4723	G	0	A	BLACK	<table border="1"> <tr><td>72</td><td>71</td><td>70</td><td>69</td><td></td><td></td><td></td><td></td><td>64</td><td>63</td><td></td><td></td><td>60</td><td>59</td><td>58</td><td></td><td>56</td><td>55</td><td>54</td><td>53</td></tr> <tr><td>52</td><td>51</td><td></td><td>49</td><td></td><td>47</td><td></td><td>45</td><td>44</td><td>43</td><td>42</td><td>41</td><td></td><td></td><td></td><td></td><td>36</td><td></td><td>34</td><td></td></tr> <tr><td></td><td></td><td></td><td></td><td>73</td><td></td><td>32</td><td></td><td>30</td><td></td><td>28</td><td>26</td><td></td><td></td><td></td><td></td><td></td><td></td><td>19</td><td>18</td></tr> <tr><td></td><td></td><td></td><td></td><td></td><td></td><td>16</td><td>15</td><td></td><td></td><td>12</td><td>10</td><td></td><td></td><td></td><td></td><td></td><td></td><td>3</td><td></td></tr> </table>	72	71	70	69					64	63			60	59	58		56	55	54	53	52	51		49		47		45	44	43	42	41					36		34						73		32		30		28	26							19	18							16	15			12	10							3			
72	71	70	69					64	63			60	59	58		56	55	54	53																																																																						
52	51		49		47		45	44	43	42	41					36		34																																																																							
				73		32		30		28	26							19	18																																																																						
						16	15			12	10							3																																																																							
AVAILABLE	NOT APPLICABLE	34566-4733	G	0	A	BLACK	<table border="1"> <tr><td>72</td><td>71</td><td>70</td><td>69</td><td></td><td></td><td></td><td></td><td>64</td><td>63</td><td></td><td></td><td>60</td><td>59</td><td>58</td><td></td><td>56</td><td>55</td><td>54</td><td>53</td></tr> <tr><td>52</td><td>51</td><td></td><td>49</td><td></td><td>47</td><td></td><td>45</td><td>44</td><td>43</td><td>42</td><td>41</td><td></td><td></td><td></td><td></td><td>36</td><td></td><td>34</td><td></td></tr> <tr><td></td><td></td><td></td><td></td><td>73</td><td></td><td>32</td><td></td><td>30</td><td></td><td>28</td><td>26</td><td></td><td></td><td></td><td></td><td>21</td><td>19</td><td>18</td><td></td></tr> <tr><td></td><td></td><td></td><td></td><td></td><td></td><td>16</td><td>15</td><td></td><td></td><td>12</td><td>10</td><td></td><td>8</td><td></td><td>5</td><td></td><td>3</td><td></td><td></td></tr> </table>	72	71	70	69					64	63			60	59	58		56	55	54	53	52	51		49		47		45	44	43	42	41					36		34						73		32		30		28	26					21	19	18								16	15			12	10		8		5		3				
72	71	70	69					64	63			60	59	58		56	55	54	53																																																																						
52	51		49		47		45	44	43	42	41					36		34																																																																							
				73		32		30		28	26					21	19	18																																																																							
						16	15			12	10		8		5		3																																																																								
AVAILABLE	NOT APPLICABLE	34566-4743	G	9	A	BLACK	<table border="1"> <tr><td>72</td><td>71</td><td>70</td><td>69</td><td></td><td>67</td><td></td><td>65</td><td>64</td><td>63</td><td>62</td><td>61</td><td>60</td><td>59</td><td>58</td><td>57</td><td>56</td><td>55</td><td>54</td><td>53</td></tr> <tr><td>52</td><td>51</td><td>50</td><td>49</td><td>48</td><td>47</td><td></td><td>45</td><td>44</td><td>43</td><td>42</td><td>41</td><td>40</td><td>39</td><td></td><td>37</td><td>36</td><td></td><td>34</td><td></td></tr> <tr><td></td><td></td><td></td><td></td><td>73</td><td></td><td>32</td><td></td><td>30</td><td>29</td><td>28</td><td>27</td><td>26</td><td></td><td>24</td><td>23</td><td></td><td>21</td><td>19</td><td>18</td><td>17</td></tr> <tr><td></td><td></td><td></td><td></td><td></td><td></td><td>16</td><td>15</td><td>14</td><td>13</td><td>12</td><td>11</td><td>10</td><td></td><td>8</td><td></td><td>5</td><td></td><td>3</td><td>2</td><td>1</td></tr> </table>	72	71	70	69		67		65	64	63	62	61	60	59	58	57	56	55	54	53	52	51	50	49	48	47		45	44	43	42	41	40	39		37	36		34						73		32		30	29	28	27	26		24	23		21	19	18	17							16	15	14	13	12	11	10		8		5		3	2	1
72	71	70	69		67		65	64	63	62	61	60	59	58	57	56	55	54	53																																																																						
52	51	50	49	48	47		45	44	43	42	41	40	39		37	36		34																																																																							
				73		32		30	29	28	27	26		24	23		21	19	18	17																																																																					
						16	15	14	13	12	11	10		8		5		3	2	1																																																																					
AVAILABLE	NOT APPLICABLE	34566-4753	G	0	B	ST.GRAY	<table border="1"> <tr><td></td><td></td><td></td><td></td><td>68</td><td>67</td><td></td><td></td><td>64</td><td></td><td></td><td></td><td></td><td></td><td></td><td></td><td>58</td><td></td><td></td><td></td></tr> <tr><td></td><td></td><td></td><td></td><td></td><td></td><td>46</td><td>45</td><td></td><td></td><td></td><td></td><td></td><td></td><td></td><td></td><td>38</td><td></td><td></td><td></td></tr> <tr><td></td><td></td><td></td><td></td><td>73</td><td></td><td>32</td><td></td><td>30</td><td>29</td><td>28</td><td>27</td><td></td><td></td><td></td><td>22</td><td></td><td></td><td></td><td>17</td></tr> <tr><td></td><td></td><td></td><td></td><td></td><td></td><td>15</td><td></td><td>13</td><td></td><td></td><td>10</td><td></td><td></td><td>6</td><td></td><td></td><td></td><td></td><td>1</td></tr> </table>					68	67			64								58										46	45									38								73		32		30	29	28	27				22				17							15		13			10			6					1		
				68	67			64								58																																																																									
						46	45									38																																																																									
				73		32		30	29	28	27				22				17																																																																						
						15		13			10			6					1																																																																						
AVAILABLE	NOT APPLICABLE	34566-4763	G	0	B	ST.GRAY	<table border="1"> <tr><td></td><td></td><td></td><td></td><td>68</td><td>67</td><td></td><td></td><td>64</td><td></td><td></td><td></td><td></td><td></td><td></td><td></td><td></td><td></td><td></td><td></td></tr> <tr><td></td><td></td><td></td><td></td><td></td><td></td><td>46</td><td>45</td><td></td><td></td><td></td><td></td><td></td><td></td><td></td><td></td><td></td><td></td><td></td><td></td></tr> <tr><td></td><td></td><td></td><td></td><td>73</td><td></td><td>32</td><td></td><td>30</td><td>29</td><td>28</td><td>27</td><td></td><td></td><td></td><td></td><td></td><td></td><td></td><td>17</td></tr> <tr><td></td><td></td><td></td><td></td><td></td><td></td><td>15</td><td></td><td>13</td><td></td><td></td><td>10</td><td></td><td></td><td>6</td><td></td><td></td><td></td><td></td><td></td></tr> </table>					68	67			64																		46	45																	73		32		30	29	28	27								17							15		13			10			6							
				68	67			64																																																																																	
						46	45																																																																																		
				73		32		30	29	28	27								17																																																																						
						15		13			10			6																																																																											
AVAILABLE	NOT APPLICABLE	34566-4773	G	0	B	ST.GRAY	<table border="1"> <tr><td></td><td></td><td></td><td></td><td>68</td><td>67</td><td></td><td></td><td>64</td><td></td><td></td><td></td><td></td><td></td><td>59</td><td>58</td><td></td><td></td><td></td><td>54</td></tr> <tr><td></td><td></td><td></td><td></td><td></td><td></td><td>46</td><td>45</td><td></td><td></td><td></td><td></td><td></td><td></td><td></td><td>39</td><td>38</td><td></td><td></td><td></td></tr> <tr><td></td><td></td><td></td><td></td><td>73</td><td></td><td>32</td><td></td><td>30</td><td>29</td><td>28</td><td>27</td><td></td><td></td><td>23</td><td>22</td><td></td><td></td><td></td><td>17</td></tr> <tr><td></td><td></td><td></td><td></td><td></td><td></td><td>15</td><td></td><td>13</td><td></td><td></td><td>10</td><td></td><td>8</td><td>6</td><td></td><td></td><td></td><td></td><td>1</td></tr> </table>					68	67			64						59	58				54							46	45								39	38								73		32		30	29	28	27			23	22				17							15		13			10		8	6					1		
				68	67			64						59	58				54																																																																						
						46	45								39	38																																																																									
				73		32		30	29	28	27			23	22				17																																																																						
						15		13			10		8	6					1																																																																						

ENTER DESCRIPTION EC NO: UAU2014-0376 DRAWN BY: CHYD APPR: VIOSHY 2013/09/05 2013/09/06 REV:	QUALITY SYMBOLS	GENERAL TOLERANCES (UNLESS SPECIFIED)	DIMENSION STYLE	SCALE	DESIGN UNITS	THIRD ANGLE PROJECTION
	∇=0 ∇=0 ∇=0	mm INCH 4 PLACES ± --- ± --- 3 PLACES ± --- ± --- 2 PLACES ± --- ± --- 1 PLACE ± --- ± --- 0 PLACE ± --- ± ---	MM ONLY	1:1	METRIC	SKRA JENDRANA 2011/02/14 MYANSLAMBROU 2011/02/14
	ANGULAR ± ---° DRAFT WHERE APPLICABLE MUST REMAIN WITHIN DIMENSIONS	DRAWN BY: SKRA JENDRANA 2011/02/14 CHECKED BY: MYANSLAMBROU 2011/02/14 APPROVED BY:	MATERIAL NO. SEE BOM TABLE DOCUMENT NO. SD-34566-001	TITLE: MX123 66/73/80CKT HRNS CONN ASSY molex	SHEET NO. 54 OF 68	
	THIS DRAWING CONTAINS INFORMATION THAT IS PROPRIETARY TO MOLEX INCORPORATED AND SHOULD NOT BE USED WITHOUT WRITTEN PERMISSION					

STATUS	GM PART #	MATERIAL #	PART/MATERIAL REVISION	WIRE DRESS OPTION	KEY OPTION	COLOR (TPA)	NUMBERS INDICATE CAVITIES OPEN FOR CIRCUITS																																																																		
AVAILABLE	NOT APPLICABLE	34566-4783	G	0	B	ST.GRY	<table border="1"> <tr><td></td><td></td><td>68</td><td>67</td><td></td><td>64</td><td>63</td><td></td><td></td><td>58</td><td></td><td>55</td><td></td></tr> <tr><td></td><td></td><td></td><td>46</td><td>45</td><td></td><td>43</td><td></td><td></td><td>38</td><td></td><td>35</td><td></td></tr> <tr><td>73</td><td></td><td>32</td><td>30</td><td>29</td><td>28</td><td>27</td><td></td><td></td><td>22</td><td></td><td>19</td><td>17</td></tr> <tr><td></td><td></td><td></td><td>15</td><td>13</td><td></td><td>10</td><td></td><td></td><td>6</td><td></td><td></td><td>1</td></tr> </table>			68	67		64	63			58		55					46	45		43			38		35		73		32	30	29	28	27			22		19	17				15	13		10			6			1														
		68	67		64	63			58		55																																																														
			46	45		43			38		35																																																														
73		32	30	29	28	27			22		19	17																																																													
			15	13		10			6			1																																																													
AVAILABLE	NOT APPLICABLE	34566-4793	G	0	B	ST.GRY	<table border="1"> <tr><td></td><td></td><td>68</td><td>67</td><td></td><td>64</td><td>63</td><td></td><td></td><td>58</td><td></td><td></td><td></td></tr> <tr><td></td><td></td><td></td><td>46</td><td>45</td><td></td><td>43</td><td></td><td></td><td>38</td><td></td><td></td><td></td></tr> <tr><td>73</td><td></td><td>32</td><td>30</td><td>29</td><td>28</td><td>27</td><td></td><td></td><td>22</td><td></td><td></td><td>17</td></tr> <tr><td></td><td></td><td></td><td>15</td><td>13</td><td></td><td>10</td><td></td><td></td><td>6</td><td></td><td></td><td></td></tr> </table>			68	67		64	63			58							46	45		43			38				73		32	30	29	28	27			22			17				15	13		10			6																	
		68	67		64	63			58																																																																
			46	45		43			38																																																																
73		32	30	29	28	27			22			17																																																													
			15	13		10			6																																																																
AVAILABLE	NOT APPLICABLE	34566-4813	G	9	B	ST.GRY	<table border="1"> <tr><td></td><td></td><td>68</td><td>67</td><td></td><td>64</td><td></td><td></td><td></td><td>59</td><td>58</td><td></td><td>54</td></tr> <tr><td></td><td></td><td></td><td>46</td><td>45</td><td></td><td></td><td></td><td></td><td>39</td><td>38</td><td></td><td></td></tr> <tr><td>73</td><td></td><td>32</td><td>30</td><td>29</td><td>28</td><td>27</td><td></td><td></td><td>23</td><td>22</td><td></td><td>17</td></tr> <tr><td></td><td></td><td></td><td>15</td><td>13</td><td></td><td>10</td><td>9</td><td>8</td><td>6</td><td></td><td></td><td>1</td></tr> </table>			68	67		64				59	58		54				46	45					39	38			73		32	30	29	28	27			23	22		17				15	13		10	9	8	6			1														
		68	67		64				59	58		54																																																													
			46	45					39	38																																																															
73		32	30	29	28	27			23	22		17																																																													
			15	13		10	9	8	6			1																																																													
AVAILABLE	NOT APPLICABLE	34566-4823	G	0	C	BLUE	<table border="1"> <tr><td></td><td></td><td>68</td><td>67</td><td>66</td><td>65</td><td>64</td><td></td><td></td><td>59</td><td>58</td><td>57</td><td>55</td><td>54</td><td>53</td></tr> <tr><td>51</td><td>50</td><td>49</td><td>48</td><td>46</td><td>45</td><td>44</td><td>43</td><td>42</td><td>41</td><td>40</td><td>39</td><td>38</td><td>37</td><td>35</td><td>33</td></tr> <tr><td>73</td><td></td><td>32</td><td>31</td><td>30</td><td></td><td></td><td>27</td><td>26</td><td>25</td><td>24</td><td></td><td>23</td><td>22</td><td>20</td><td></td></tr> <tr><td></td><td></td><td></td><td>16</td><td></td><td></td><td>13</td><td></td><td>10</td><td>9</td><td>8</td><td>7</td><td>6</td><td>5</td><td>4</td><td>3</td><td>2</td></tr> </table>			68	67	66	65	64			59	58	57	55	54	53	51	50	49	48	46	45	44	43	42	41	40	39	38	37	35	33	73		32	31	30			27	26	25	24		23	22	20					16			13		10	9	8	7	6	5	4	3	2		
		68	67	66	65	64			59	58	57	55	54	53																																																											
51	50	49	48	46	45	44	43	42	41	40	39	38	37	35	33																																																										
73		32	31	30			27	26	25	24		23	22	20																																																											
			16			13		10	9	8	7	6	5	4	3	2																																																									
AVAILABLE	NOT APPLICABLE	34566-4833	G	0	C	BLUE	<table border="1"> <tr><td>72</td><td>70</td><td>68</td><td>67</td><td>66</td><td></td><td>63</td><td>62</td><td></td><td>59</td><td>57</td><td></td><td></td><td></td><td>53</td></tr> <tr><td>52</td><td>51</td><td></td><td>48</td><td>47</td><td>46</td><td>44</td><td>42</td><td></td><td>40</td><td>39</td><td></td><td>37</td><td>36</td><td></td><td>34</td><td>33</td></tr> <tr><td>73</td><td></td><td>32</td><td></td><td>30</td><td></td><td></td><td>27</td><td>26</td><td>25</td><td>24</td><td></td><td>22</td><td>21</td><td></td><td></td><td></td></tr> <tr><td></td><td></td><td></td><td>15</td><td>14</td><td></td><td></td><td>10</td><td>9</td><td>8</td><td></td><td></td><td>6</td><td>5</td><td>4</td><td></td><td>2</td></tr> </table>	72	70	68	67	66		63	62		59	57				53	52	51		48	47	46	44	42		40	39		37	36		34	33	73		32		30			27	26	25	24		22	21							15	14			10	9	8			6	5	4		2
72	70	68	67	66		63	62		59	57				53																																																											
52	51		48	47	46	44	42		40	39		37	36		34	33																																																									
73		32		30			27	26	25	24		22	21																																																												
			15	14			10	9	8			6	5	4		2																																																									
AVAILABLE	NOT APPLICABLE	34566-4843	G	0	C	BLUE	<table border="1"> <tr><td>72</td><td>70</td><td>68</td><td>67</td><td>66</td><td></td><td>63</td><td>62</td><td></td><td>59</td><td>57</td><td></td><td></td><td></td><td>53</td></tr> <tr><td>52</td><td>51</td><td></td><td>48</td><td>47</td><td>46</td><td>44</td><td>42</td><td></td><td>40</td><td>39</td><td></td><td>37</td><td>36</td><td></td><td>34</td><td>33</td></tr> <tr><td>73</td><td></td><td>32</td><td></td><td>30</td><td></td><td></td><td>27</td><td>26</td><td>25</td><td>24</td><td></td><td>22</td><td>21</td><td></td><td></td><td></td></tr> <tr><td></td><td></td><td></td><td>15</td><td>14</td><td></td><td></td><td>10</td><td>9</td><td>8</td><td></td><td></td><td>6</td><td>5</td><td>4</td><td></td><td>2</td></tr> </table>	72	70	68	67	66		63	62		59	57				53	52	51		48	47	46	44	42		40	39		37	36		34	33	73		32		30			27	26	25	24		22	21							15	14			10	9	8			6	5	4		2
72	70	68	67	66		63	62		59	57				53																																																											
52	51		48	47	46	44	42		40	39		37	36		34	33																																																									
73		32		30			27	26	25	24		22	21																																																												
			15	14			10	9	8			6	5	4		2																																																									
AVAILABLE	NOT APPLICABLE	34566-4853	G	0	C	BLUE	<table border="1"> <tr><td>72</td><td>70</td><td>68</td><td></td><td>66</td><td></td><td>63</td><td>62</td><td></td><td>59</td><td>57</td><td>56</td><td>55</td><td></td><td>53</td></tr> <tr><td>52</td><td>51</td><td></td><td>48</td><td>47</td><td>46</td><td>44</td><td>42</td><td></td><td>40</td><td>39</td><td></td><td>37</td><td>36</td><td></td><td>34</td><td>33</td></tr> <tr><td>73</td><td></td><td>32</td><td></td><td>30</td><td></td><td></td><td>27</td><td>26</td><td>25</td><td>24</td><td></td><td>22</td><td>21</td><td></td><td>19</td><td>18</td></tr> <tr><td></td><td></td><td></td><td>15</td><td>14</td><td></td><td></td><td>10</td><td>9</td><td>8</td><td></td><td></td><td>6</td><td>5</td><td>4</td><td>3</td><td>2</td></tr> </table>	72	70	68		66		63	62		59	57	56	55		53	52	51		48	47	46	44	42		40	39		37	36		34	33	73		32		30			27	26	25	24		22	21		19	18				15	14			10	9	8			6	5	4	3	2
72	70	68		66		63	62		59	57	56	55		53																																																											
52	51		48	47	46	44	42		40	39		37	36		34	33																																																									
73		32		30			27	26	25	24		22	21		19	18																																																									
			15	14			10	9	8			6	5	4	3	2																																																									
AVAILABLE	NOT APPLICABLE	34566-4863	G	0	C	BLUE	<table border="1"> <tr><td>72</td><td>70</td><td>68</td><td></td><td>66</td><td></td><td>63</td><td>62</td><td></td><td>59</td><td>57</td><td></td><td></td><td></td><td>53</td></tr> <tr><td>52</td><td>51</td><td></td><td>48</td><td>47</td><td>46</td><td>44</td><td>42</td><td></td><td>40</td><td>39</td><td></td><td>37</td><td>36</td><td></td><td>34</td><td>33</td></tr> <tr><td>73</td><td></td><td>32</td><td></td><td>30</td><td></td><td></td><td>27</td><td>26</td><td>25</td><td>24</td><td></td><td>22</td><td>21</td><td></td><td></td><td></td></tr> <tr><td></td><td></td><td></td><td>15</td><td>14</td><td></td><td></td><td>10</td><td>9</td><td>8</td><td></td><td></td><td>6</td><td>5</td><td>4</td><td></td><td>2</td></tr> </table>	72	70	68		66		63	62		59	57				53	52	51		48	47	46	44	42		40	39		37	36		34	33	73		32		30			27	26	25	24		22	21							15	14			10	9	8			6	5	4		2
72	70	68		66		63	62		59	57				53																																																											
52	51		48	47	46	44	42		40	39		37	36		34	33																																																									
73		32		30			27	26	25	24		22	21																																																												
			15	14			10	9	8			6	5	4		2																																																									
AVAILABLE	NOT APPLICABLE	34566-4873	G	0	C	BLUE	<table border="1"> <tr><td>72</td><td>70</td><td>68</td><td></td><td>66</td><td></td><td>63</td><td>62</td><td></td><td>59</td><td>57</td><td></td><td></td><td></td><td>53</td></tr> <tr><td>52</td><td>51</td><td></td><td>48</td><td>47</td><td>46</td><td>44</td><td>42</td><td></td><td>40</td><td>39</td><td></td><td>37</td><td>36</td><td></td><td>34</td><td>33</td></tr> <tr><td>73</td><td></td><td>32</td><td></td><td>30</td><td></td><td></td><td>27</td><td>26</td><td>25</td><td>24</td><td></td><td>22</td><td>21</td><td></td><td></td><td></td></tr> <tr><td></td><td></td><td></td><td>15</td><td>14</td><td></td><td></td><td>10</td><td>9</td><td>8</td><td></td><td></td><td>6</td><td>5</td><td>4</td><td></td><td>2</td></tr> </table>	72	70	68		66		63	62		59	57				53	52	51		48	47	46	44	42		40	39		37	36		34	33	73		32		30			27	26	25	24		22	21							15	14			10	9	8			6	5	4		2
72	70	68		66		63	62		59	57				53																																																											
52	51		48	47	46	44	42		40	39		37	36		34	33																																																									
73		32		30			27	26	25	24		22	21																																																												
			15	14			10	9	8			6	5	4		2																																																									

ENTER DESCRIPTION IEC NO: UAU2014-0376 DRAWN BY: 2013/09/05 CHKD: 2013/09/06 APPR: WOSHY REV: 2013/09/06	QUALITY SYMBOLS	GENERAL TOLERANCES (UNLESS SPECIFIED)	DIMENSION STYLE	SCALE	DESIGN UNITS	THIRD ANGLE PROJECTION	
	∇=0 ∇=0 ∇=0	4 PLACES ±---+--- 3 PLACES ±---+--- 2 PLACES ±---+--- 1 PLACE ±---+--- 0 PLACE ±---+---	mm INCH ±---+--- ±---+--- ±---+--- ±---+--- ±---+---	MM ONLY	1:1	METRIC	SKRAJENDRANA 2011/02/14 MVANSLAMBROU 2011/02/14
	ANGULAR ±---° DRAFT WHERE APPLICABLE MUST REMAIN WITHIN DIMENSIONS	SEE BOM TABLE THIS DRAWING CONTAINS INFORMATION THAT IS PROPRIETARY TO MOLEX INCORPORATED AND SHOULD NOT BE USED WITHOUT WRITTEN PERMISSION	MATERIAL NO. DOCUMENT NO.	MX123 66/73/80CKT HRNS CONN ASSY molex SD-34566-001	SHEET NO. 55 OF 68		

STATUS	GM PART #	MATERIAL #	PART/MATERIAL REVISION	WIRE DRESS OPTION	KEY OPTION	COLOR (TFA)	NUMBERS INDICATE CAVITIES OPEN FOR CIRCUITS																																																																					
AVAILABLE	NOT APPLICABLE	34566-4883	G	9	A	BLACK	<table border="1"> <tr><td>72</td><td></td><td>69</td><td>67</td><td>65</td><td>63</td><td></td><td>60</td><td></td><td>57</td><td>56</td><td></td><td>53</td></tr> <tr><td></td><td></td><td>49</td><td>47</td><td>46</td><td>44</td><td>43</td><td>40</td><td></td><td>37</td><td>36</td><td>35</td><td>33</td></tr> <tr><td>73</td><td></td><td></td><td>31</td><td>30</td><td>29</td><td>28</td><td></td><td>24</td><td></td><td>21</td><td>20</td><td>17</td></tr> <tr><td></td><td></td><td></td><td>16</td><td>15</td><td>14</td><td>13</td><td></td><td>11</td><td>10</td><td></td><td>5</td><td>4</td><td>3</td><td>2</td><td>1</td></tr> </table>	72		69	67	65	63		60		57	56		53			49	47	46	44	43	40		37	36	35	33	73			31	30	29	28		24		21	20	17				16	15	14	13		11	10		5	4	3	2	1														
72		69	67	65	63		60		57	56		53																																																																
		49	47	46	44	43	40		37	36	35	33																																																																
73			31	30	29	28		24		21	20	17																																																																
			16	15	14	13		11	10		5	4	3	2	1																																																													
AVAILABLE	NOT APPLICABLE	34566-4893	G	9	B	ST.GRAY	<table border="1"> <tr><td></td><td></td><td>68</td><td>67</td><td></td><td>64</td><td>63</td><td></td><td></td><td>58</td><td></td><td>55</td><td></td></tr> <tr><td></td><td></td><td></td><td>46</td><td>45</td><td>43</td><td></td><td></td><td></td><td>38</td><td></td><td>35</td><td></td></tr> <tr><td>73</td><td></td><td>32</td><td>30</td><td>29</td><td>28</td><td>27</td><td></td><td></td><td>22</td><td></td><td>19</td><td>17</td></tr> <tr><td></td><td></td><td></td><td>15</td><td>13</td><td></td><td></td><td>10</td><td></td><td></td><td></td><td></td><td></td><td></td><td></td><td>1</td></tr> </table>			68	67		64	63			58		55					46	45	43				38		35		73		32	30	29	28	27			22		19	17				15	13			10								1														
		68	67		64	63			58		55																																																																	
			46	45	43				38		35																																																																	
73		32	30	29	28	27			22		19	17																																																																
			15	13			10								1																																																													
AVAILABLE	NOT APPLICABLE	34566-4913	G	9	B	ST.GRAY	<table border="1"> <tr><td></td><td></td><td>68</td><td>67</td><td></td><td>64</td><td>63</td><td></td><td></td><td>58</td><td>57</td><td>55</td><td>53</td></tr> <tr><td></td><td></td><td></td><td>46</td><td>45</td><td>43</td><td></td><td></td><td></td><td>38</td><td>37</td><td>35</td><td></td></tr> <tr><td>73</td><td></td><td>32</td><td>30</td><td>29</td><td>28</td><td>27</td><td></td><td></td><td>22</td><td>21</td><td>19</td><td>17</td></tr> <tr><td></td><td></td><td></td><td></td><td></td><td>12</td><td>10</td><td></td><td></td><td></td><td></td><td></td><td></td><td></td><td></td><td>1</td></tr> </table>			68	67		64	63			58	57	55	53				46	45	43				38	37	35		73		32	30	29	28	27			22	21	19	17						12	10									1														
		68	67		64	63			58	57	55	53																																																																
			46	45	43				38	37	35																																																																	
73		32	30	29	28	27			22	21	19	17																																																																
					12	10									1																																																													
AVAILABLE	NOT APPLICABLE	34566-4923	G	9	A	BLACK	<table border="1"> <tr><td>72</td><td></td><td>69</td><td>67</td><td>65</td><td>63</td><td></td><td>60</td><td></td><td>57</td><td>56</td><td></td><td>53</td></tr> <tr><td></td><td></td><td>49</td><td>47</td><td></td><td>44</td><td>43</td><td>40</td><td></td><td>37</td><td>36</td><td>35</td><td>33</td></tr> <tr><td>73</td><td></td><td></td><td>31</td><td>30</td><td>29</td><td>28</td><td></td><td>24</td><td></td><td>21</td><td>20</td><td>17</td></tr> <tr><td></td><td></td><td></td><td>16</td><td>15</td><td>14</td><td>13</td><td></td><td>11</td><td>10</td><td></td><td>5</td><td>4</td><td>3</td><td>2</td><td>1</td></tr> </table>	72		69	67	65	63		60		57	56		53			49	47		44	43	40		37	36	35	33	73			31	30	29	28		24		21	20	17				16	15	14	13		11	10		5	4	3	2	1														
72		69	67	65	63		60		57	56		53																																																																
		49	47		44	43	40		37	36	35	33																																																																
73			31	30	29	28		24		21	20	17																																																																
			16	15	14	13		11	10		5	4	3	2	1																																																													
AVAILABLE	NOT APPLICABLE	34566-4933	G	0	C	BLUE	<table border="1"> <tr><td>72</td><td>70</td><td>68</td><td>67</td><td></td><td>63</td><td>62</td><td></td><td>59</td><td>57</td><td></td><td></td><td>53</td></tr> <tr><td>52</td><td>51</td><td></td><td>48</td><td>47</td><td>46</td><td>44</td><td></td><td>40</td><td>39</td><td>37</td><td>36</td><td>35</td><td>34</td><td>33</td></tr> <tr><td>73</td><td></td><td>32</td><td>30</td><td></td><td>27</td><td>26</td><td>25</td><td>24</td><td>22</td><td>21</td><td></td><td></td><td></td><td></td></tr> <tr><td></td><td></td><td></td><td>15</td><td>14</td><td></td><td></td><td>10</td><td>9</td><td>8</td><td>6</td><td>5</td><td>4</td><td></td><td>2</td></tr> </table>	72	70	68	67		63	62		59	57			53	52	51		48	47	46	44		40	39	37	36	35	34	33	73		32	30		27	26	25	24	22	21								15	14			10	9	8	6	5	4		2											
72	70	68	67		63	62		59	57			53																																																																
52	51		48	47	46	44		40	39	37	36	35	34	33																																																														
73		32	30		27	26	25	24	22	21																																																																		
			15	14			10	9	8	6	5	4		2																																																														
AVAILABLE	NOT APPLICABLE	34566-4943	G	0	A	BLACK	<table border="1"> <tr><td></td><td>70</td><td>69</td><td>68</td><td>67</td><td></td><td>63</td><td>62</td><td>61</td><td>60</td><td>59</td><td>58</td><td>57</td><td>56</td><td>55</td><td>54</td><td>53</td></tr> <tr><td>52</td><td>51</td><td>50</td><td>49</td><td></td><td></td><td>44</td><td>43</td><td>42</td><td>41</td><td>39</td><td>38</td><td>37</td><td>36</td><td></td><td>34</td><td></td></tr> <tr><td>73</td><td></td><td></td><td>32</td><td>31</td><td></td><td>29</td><td>28</td><td>27</td><td>26</td><td>25</td><td>23</td><td></td><td></td><td>19</td><td>18</td><td></td></tr> <tr><td></td><td></td><td></td><td></td><td>16</td><td>15</td><td>14</td><td>13</td><td>12</td><td>11</td><td>10</td><td>9</td><td>8</td><td></td><td></td><td>3</td><td></td></tr> </table>		70	69	68	67		63	62	61	60	59	58	57	56	55	54	53	52	51	50	49			44	43	42	41	39	38	37	36		34		73			32	31		29	28	27	26	25	23			19	18						16	15	14	13	12	11	10	9	8			3		
	70	69	68	67		63	62	61	60	59	58	57	56	55	54	53																																																												
52	51	50	49			44	43	42	41	39	38	37	36		34																																																													
73			32	31		29	28	27	26	25	23			19	18																																																													
				16	15	14	13	12	11	10	9	8			3																																																													
AVAILABLE	NOT APPLICABLE	34566-4953	G	0	B	ST.GRAY	<table border="1"> <tr><td>72</td><td>71</td><td>70</td><td>69</td><td>68</td><td>67</td><td>66</td><td>65</td><td>64</td><td>63</td><td></td><td>59</td><td></td><td></td><td></td><td>53</td></tr> <tr><td>52</td><td>51</td><td>50</td><td>49</td><td>48</td><td>47</td><td>46</td><td>45</td><td>44</td><td>43</td><td></td><td>39</td><td></td><td></td><td></td><td>34</td><td>33</td></tr> <tr><td>73</td><td></td><td></td><td>32</td><td>31</td><td>30</td><td>29</td><td>28</td><td>27</td><td>26</td><td>25</td><td>24</td><td>23</td><td></td><td></td><td>19</td><td>18</td><td>17</td></tr> <tr><td></td><td></td><td></td><td></td><td>16</td><td>15</td><td>14</td><td>13</td><td>12</td><td>11</td><td>10</td><td>8</td><td>7</td><td></td><td></td><td>3</td><td>2</td><td>1</td></tr> </table>	72	71	70	69	68	67	66	65	64	63		59				53	52	51	50	49	48	47	46	45	44	43		39				34	33	73			32	31	30	29	28	27	26	25	24	23			19	18	17					16	15	14	13	12	11	10	8	7			3	2	1
72	71	70	69	68	67	66	65	64	63		59				53																																																													
52	51	50	49	48	47	46	45	44	43		39				34	33																																																												
73			32	31	30	29	28	27	26	25	24	23			19	18	17																																																											
				16	15	14	13	12	11	10	8	7			3	2	1																																																											
AVAILABLE	NOT APPLICABLE	34566-4963	G	9	A	BLACK	<table border="1"> <tr><td>72</td><td></td><td>69</td><td>67</td><td>66</td><td>65</td><td>63</td><td></td><td>60</td><td></td><td>57</td><td>56</td><td></td><td>53</td></tr> <tr><td></td><td></td><td>49</td><td>47</td><td>46</td><td>44</td><td>43</td><td>42</td><td>40</td><td></td><td>37</td><td>36</td><td>35</td><td>33</td></tr> <tr><td>73</td><td></td><td></td><td>31</td><td>30</td><td>29</td><td>28</td><td>27</td><td>26</td><td>24</td><td></td><td>21</td><td>20</td><td>17</td></tr> <tr><td></td><td></td><td></td><td>16</td><td>15</td><td>14</td><td>13</td><td></td><td>11</td><td>10</td><td></td><td>5</td><td>4</td><td>3</td><td>2</td><td>1</td></tr> </table>	72		69	67	66	65	63		60		57	56		53			49	47	46	44	43	42	40		37	36	35	33	73			31	30	29	28	27	26	24		21	20	17				16	15	14	13		11	10		5	4	3	2	1											
72		69	67	66	65	63		60		57	56		53																																																															
		49	47	46	44	43	42	40		37	36	35	33																																																															
73			31	30	29	28	27	26	24		21	20	17																																																															
			16	15	14	13		11	10		5	4	3	2	1																																																													
AVAILABLE	NOT APPLICABLE	34566-4973	G	9	B	ST.GRAY	<table border="1"> <tr><td></td><td></td><td>68</td><td>67</td><td></td><td>64</td><td>63</td><td></td><td></td><td>59</td><td>58</td><td></td><td></td><td>54</td></tr> <tr><td></td><td></td><td></td><td>46</td><td>45</td><td>44</td><td>43</td><td></td><td></td><td>39</td><td>38</td><td></td><td></td><td></td></tr> <tr><td>73</td><td></td><td>32</td><td>30</td><td>29</td><td>28</td><td>27</td><td></td><td></td><td>23</td><td>22</td><td></td><td></td><td>17</td></tr> <tr><td></td><td></td><td></td><td>15</td><td>13</td><td>12</td><td>10</td><td></td><td></td><td>6</td><td></td><td></td><td></td><td></td><td></td><td>1</td></tr> </table>			68	67		64	63			59	58			54				46	45	44	43			39	38				73		32	30	29	28	27			23	22			17				15	13	12	10			6						1											
		68	67		64	63			59	58			54																																																															
			46	45	44	43			39	38																																																																		
73		32	30	29	28	27			23	22			17																																																															
			15	13	12	10			6						1																																																													

ENTER DESCRIPTION IEC NO. UAU2014-0376 DRAWN BY CHKD: APPR:VKOSHY 2013/09/05 2013/09/06	QUALITY SYMBOLS	GENERAL TOLERANCES (UNLESS SPECIFIED)	DIMENSION STYLE	SCALE	DESIGN UNITS	THIRD ANGLE PROJECTION	
	∇=0 ∇=0 ∇=0	mm INCH 4 PLACES ±--- ±--- 3 PLACES ±--- ±--- 2 PLACES ±--- ±--- 1 PLACE ±--- ±--- 0 PLACE ±--- ±---	MM ONLY	1:1	METRIC	DRAWN BY SKRA JENDRANA 2011/02/14 CHECKED BY MVANSLAMBROU 2011/02/14 APPROVED BY	MX123 66/73/80CKT HRNS CONN ASSY molex
	ANGULAR ±--- DRAFT WHERE APPLICABLE MUST REMAIN WITHIN DIMENSIONS	MATERIAL NO. SEE BOM TABLE	DOCUMENT NO. SD-34566-001	SHEET NO. 56 OF 68			
	THIS DRAWING CONTAINS INFORMATION THAT IS PROPRIETARY TO MOLEX INCORPORATED AND SHOULD NOT BE USED WITHOUT WRITTEN PERMISSION						

STATUS	GM PART #	MATERIAL #	PART/MATERIAL REVISION	WIRE DRESS OPTION	KEY OPTION	COLOR (TPA)	NUMBERS INDICATE CAVITIES OPEN FOR CIRCUITS																																																																																
AVAILABLE	NOT APPLICABLE	34566-4983	G	0	B	ST.GRAY	<table border="1"> <tr><td>72</td><td>70</td><td>68</td><td>66</td><td></td><td></td><td></td><td>60</td><td>59</td><td></td><td></td><td></td><td>55</td><td>54</td><td>53</td></tr> <tr><td>52</td><td>50</td><td>48</td><td>46</td><td>44</td><td></td><td></td><td>40</td><td>39</td><td></td><td></td><td></td><td>35</td><td>34</td><td>33</td></tr> <tr><td></td><td>73</td><td>32</td><td>31</td><td>30</td><td>29</td><td>28</td><td>27</td><td>26</td><td>25</td><td>24</td><td>23</td><td></td><td>19</td><td>18</td><td>17</td></tr> <tr><td></td><td></td><td>16</td><td></td><td></td><td></td><td></td><td>10</td><td>8</td><td>7</td><td></td><td></td><td></td><td>2</td><td>1</td><td></td></tr> </table>	72	70	68	66				60	59				55	54	53	52	50	48	46	44			40	39				35	34	33		73	32	31	30	29	28	27	26	25	24	23		19	18	17			16					10	8	7				2	1																			
72	70	68	66				60	59				55	54	53																																																																									
52	50	48	46	44			40	39				35	34	33																																																																									
	73	32	31	30	29	28	27	26	25	24	23		19	18	17																																																																								
		16					10	8	7				2	1																																																																									
AVAILABLE	NOT APPLICABLE	34566-4993	G	0	A	BLACK	<table border="1"> <tr><td>72</td><td>71</td><td>70</td><td>69</td><td></td><td>67</td><td></td><td>64</td><td>63</td><td></td><td>60</td><td>59</td><td></td><td>56</td><td>55</td><td>54</td><td>53</td></tr> <tr><td>52</td><td>51</td><td></td><td>49</td><td></td><td>47</td><td></td><td>45</td><td>44</td><td>43</td><td>42</td><td>41</td><td></td><td></td><td>36</td><td>34</td><td></td></tr> <tr><td></td><td></td><td></td><td>73</td><td></td><td>32</td><td></td><td>28</td><td>26</td><td></td><td></td><td></td><td></td><td></td><td>19</td><td>18</td><td></td></tr> <tr><td></td><td></td><td></td><td></td><td></td><td>16</td><td>15</td><td></td><td>12</td><td>10</td><td></td><td></td><td></td><td></td><td>3</td><td></td><td></td></tr> </table>	72	71	70	69		67		64	63		60	59		56	55	54	53	52	51		49		47		45	44	43	42	41			36	34					73		32		28	26						19	18							16	15		12	10					3														
72	71	70	69		67		64	63		60	59		56	55	54	53																																																																							
52	51		49		47		45	44	43	42	41			36	34																																																																								
			73		32		28	26						19	18																																																																								
					16	15		12	10					3																																																																									
AVAILABLE	NOT APPLICABLE	34566-5013	G	9	B	ST.GRAY	<table border="1"> <tr><td></td><td></td><td></td><td>68</td><td>67</td><td></td><td>64</td><td>63</td><td></td><td></td><td>59</td><td>58</td><td></td><td>55</td><td>54</td><td></td><td></td></tr> <tr><td></td><td></td><td></td><td></td><td></td><td>46</td><td>45</td><td>44</td><td>43</td><td></td><td>39</td><td>38</td><td></td><td></td><td>35</td><td></td><td></td></tr> <tr><td></td><td></td><td></td><td>73</td><td></td><td>32</td><td>30</td><td>29</td><td>28</td><td>27</td><td></td><td>23</td><td>22</td><td></td><td>19</td><td>17</td><td></td></tr> <tr><td></td><td></td><td></td><td></td><td></td><td>15</td><td>13</td><td>12</td><td>10</td><td></td><td></td><td>6</td><td></td><td></td><td></td><td></td><td>1</td></tr> </table>				68	67		64	63			59	58		55	54								46	45	44	43		39	38			35						73		32	30	29	28	27		23	22		19	17							15	13	12	10			6					1												
			68	67		64	63			59	58		55	54																																																																									
					46	45	44	43		39	38			35																																																																									
			73		32	30	29	28	27		23	22		19	17																																																																								
					15	13	12	10			6					1																																																																							
AVAILABLE	NOT APPLICABLE	34566-5023	G	0	C	BLUE	<table border="1"> <tr><td>72</td><td>70</td><td>68</td><td>67</td><td></td><td></td><td>63</td><td>62</td><td></td><td>59</td><td>57</td><td></td><td></td><td></td><td>53</td><td></td><td></td></tr> <tr><td>52</td><td>51</td><td></td><td>48</td><td>47</td><td>46</td><td>44</td><td>42</td><td>40</td><td>39</td><td></td><td>37</td><td>36</td><td></td><td>34</td><td>33</td><td></td></tr> <tr><td></td><td></td><td></td><td>73</td><td></td><td>32</td><td>30</td><td></td><td>26</td><td>25</td><td>24</td><td></td><td>22</td><td>21</td><td>20</td><td></td><td></td></tr> <tr><td></td><td></td><td></td><td></td><td></td><td>15</td><td>14</td><td></td><td></td><td>8</td><td>6</td><td>5</td><td>4</td><td></td><td>2</td><td></td><td></td></tr> </table>	72	70	68	67			63	62		59	57				53			52	51		48	47	46	44	42	40	39		37	36		34	33					73		32	30		26	25	24		22	21	20								15	14			8	6	5	4		2														
72	70	68	67			63	62		59	57				53																																																																									
52	51		48	47	46	44	42	40	39		37	36		34	33																																																																								
			73		32	30		26	25	24		22	21	20																																																																									
					15	14			8	6	5	4		2																																																																									
AVAILABLE	NOT APPLICABLE	34566-5033	G	0	A	BLACK	<table border="1"> <tr><td></td><td>70</td><td>69</td><td></td><td></td><td></td><td>63</td><td>62</td><td>61</td><td>60</td><td></td><td>58</td><td>57</td><td>56</td><td>55</td><td>54</td><td>53</td></tr> <tr><td>52</td><td>51</td><td>49</td><td></td><td></td><td></td><td>44</td><td>43</td><td>42</td><td>41</td><td></td><td></td><td>37</td><td>36</td><td>35</td><td>34</td><td>33</td></tr> <tr><td></td><td></td><td></td><td>73</td><td></td><td></td><td>32</td><td></td><td>29</td><td>28</td><td>27</td><td>26</td><td>25</td><td></td><td></td><td>19</td><td>18</td></tr> <tr><td></td><td></td><td></td><td></td><td></td><td></td><td>16</td><td>15</td><td>13</td><td>12</td><td>11</td><td>10</td><td></td><td></td><td></td><td>3</td><td></td></tr> </table>		70	69				63	62	61	60		58	57	56	55	54	53	52	51	49				44	43	42	41			37	36	35	34	33				73			32		29	28	27	26	25			19	18							16	15	13	12	11	10				3													
	70	69				63	62	61	60		58	57	56	55	54	53																																																																							
52	51	49				44	43	42	41			37	36	35	34	33																																																																							
			73			32		29	28	27	26	25			19	18																																																																							
						16	15	13	12	11	10				3																																																																								
AVAILABLE	NOT APPLICABLE	34566-5043	G	0	A	BLACK	<table border="1"> <tr><td></td><td></td><td></td><td></td><td></td><td></td><td></td><td></td><td></td><td></td><td></td><td></td><td></td><td></td><td></td><td></td><td></td></tr> <tr><td></td><td></td><td></td><td></td><td></td><td></td><td></td><td></td><td></td><td></td><td></td><td></td><td></td><td></td><td></td><td></td><td></td></tr> <tr><td></td><td></td><td></td><td>73</td><td></td><td></td><td>31</td><td></td><td></td><td></td><td></td><td></td><td></td><td></td><td></td><td></td><td></td></tr> </table>																																						73			31																																							
			73			31																																																																																	
AVAILABLE	NOT APPLICABLE	34566-5053	G	0	B	ST.GRAY	<table border="1"> <tr><td></td><td></td><td></td><td></td><td></td><td></td><td></td><td></td><td></td><td></td><td></td><td></td><td></td><td></td><td></td><td></td><td></td></tr> <tr><td></td><td></td><td></td><td></td><td></td><td></td><td></td><td></td><td></td><td></td><td></td><td></td><td></td><td></td><td></td><td></td><td></td></tr> <tr><td></td><td></td><td></td><td>73</td><td></td><td></td><td>47</td><td></td><td></td><td></td><td></td><td></td><td></td><td></td><td></td><td>20</td><td>17</td></tr> <tr><td></td><td></td><td></td><td></td><td></td><td></td><td>31</td><td></td><td></td><td></td><td></td><td></td><td></td><td></td><td></td><td></td><td>1</td></tr> </table>																																						73			47									20	17							31										1												
			73			47									20	17																																																																							
						31										1																																																																							
AVAILABLE	NOT APPLICABLE	34566-5063	G	9	H	ST.GRAY	<table border="1"> <tr><td>80</td><td>79</td><td>78</td><td>77</td><td>76</td><td>75</td><td>74</td><td>73</td><td>72</td><td>71</td><td>70</td><td>69</td><td>68</td><td>67</td><td>66</td><td>65</td><td>64</td><td>63</td><td>62</td><td>61</td></tr> <tr><td>60</td><td>59</td><td>58</td><td>57</td><td>56</td><td>55</td><td>54</td><td>53</td><td>52</td><td>51</td><td>50</td><td>49</td><td>48</td><td>47</td><td>46</td><td>45</td><td>44</td><td>43</td><td>42</td><td>41</td></tr> <tr><td>40</td><td>39</td><td>38</td><td>37</td><td></td><td>35</td><td>34</td><td>33</td><td>32</td><td>30</td><td>29</td><td>27</td><td>26</td><td></td><td>24</td><td>23</td><td>22</td><td>21</td><td></td><td></td></tr> <tr><td>20</td><td>19</td><td>18</td><td>17</td><td></td><td></td><td>14</td><td>13</td><td>12</td><td>11</td><td>10</td><td>9</td><td>8</td><td></td><td>6</td><td>5</td><td>3</td><td>2</td><td></td><td></td></tr> </table>	80	79	78	77	76	75	74	73	72	71	70	69	68	67	66	65	64	63	62	61	60	59	58	57	56	55	54	53	52	51	50	49	48	47	46	45	44	43	42	41	40	39	38	37		35	34	33	32	30	29	27	26		24	23	22	21			20	19	18	17			14	13	12	11	10	9	8		6	5	3	2		
80	79	78	77	76	75	74	73	72	71	70	69	68	67	66	65	64	63	62	61																																																																				
60	59	58	57	56	55	54	53	52	51	50	49	48	47	46	45	44	43	42	41																																																																				
40	39	38	37		35	34	33	32	30	29	27	26		24	23	22	21																																																																						
20	19	18	17			14	13	12	11	10	9	8		6	5	3	2																																																																						
AVAILABLE	NOT APPLICABLE	34566-5073	G	9	A	BLACK	<table border="1"> <tr><td>72</td><td>71</td><td>70</td><td>69</td><td>68</td><td>67</td><td>66</td><td>65</td><td>64</td><td>63</td><td>62</td><td>61</td><td>60</td><td>59</td><td>58</td><td>57</td><td>56</td><td>55</td><td>54</td><td>53</td></tr> <tr><td>52</td><td>51</td><td>50</td><td>49</td><td>48</td><td>47</td><td>46</td><td>45</td><td>44</td><td>43</td><td>42</td><td>41</td><td>40</td><td>39</td><td>38</td><td>37</td><td>36</td><td></td><td>34</td><td>33</td></tr> <tr><td></td><td></td><td></td><td>73</td><td></td><td></td><td>32</td><td>31</td><td>30</td><td>29</td><td>28</td><td>27</td><td>26</td><td>24</td><td>23</td><td>22</td><td>21</td><td>20</td><td>19</td><td>18</td></tr> <tr><td></td><td></td><td></td><td></td><td></td><td></td><td>16</td><td></td><td></td><td>13</td><td>12</td><td>11</td><td>10</td><td>9</td><td>8</td><td></td><td></td><td></td><td></td><td>1</td></tr> </table>	72	71	70	69	68	67	66	65	64	63	62	61	60	59	58	57	56	55	54	53	52	51	50	49	48	47	46	45	44	43	42	41	40	39	38	37	36		34	33				73			32	31	30	29	28	27	26	24	23	22	21	20	19	18							16			13	12	11	10	9	8					1
72	71	70	69	68	67	66	65	64	63	62	61	60	59	58	57	56	55	54	53																																																																				
52	51	50	49	48	47	46	45	44	43	42	41	40	39	38	37	36		34	33																																																																				
			73			32	31	30	29	28	27	26	24	23	22	21	20	19	18																																																																				
						16			13	12	11	10	9	8					1																																																																				

ENTER DESCRIPTION IEC NO. UAU2014-0376 DRAWN BY 2013/09/05 CHYK: APPR:VKOSHY 2013/09/06 DESCRIPTION	QUALITY SYMBOLS	GENERAL TOLERANCES (UNLESS SPECIFIED)	DIMENSION STYLE	SCALE	DESIGN UNITS	THIRD ANGLE PROJECTION
	▽=0	mm INCH	MM ONLY	1:1	METRIC	
	▽=0	4 PLACES ±--- ±---	DRAWN BY DATE			
	▽=0	3 PLACES ±--- ±---	SKRA JENDRANA 2011/02/14			
	2 PLACES ±--- ±---	CHECKED BY DATE				
	1 PLACE ±--- ±---	MVANS LAMBROU 2011/02/14				
	0 PLACE ±--- ±---	APPROVED BY DATE				
	ANGULAR ±--- ±---	MATERIAL NO.				
	DRAFT WHERE APPLICABLE MUST REMAIN WITHIN DIMENSIONS	SEE BOM TABLE				
		SIZE D				

MX123
66/73/80CKT
HRNS CONN ASSY

SD-34566-001

SHEET NO. 57 OF 68

THIS DRAWING CONTAINS INFORMATION THAT IS PROPRIETARY TO MOLEX INCORPORATED AND SHOULD NOT BE USED WITHOUT WRITTEN PERMISSION

STATUS	GM PART #	MATERIAL #	PART/MATERIAL REVISION	WIRE DRESS OPTION	KEY OPTION	COLOR (TPA)	NUMBERS INDICATE CAVITIES OPEN FOR CIRCUITS																																																																																							
AVAILABLE	NOT APPLICABLE	34566-5183	G	0	B	ST.GRAY	<table border="1"> <tr><td></td><td></td><td></td><td></td><td>68</td><td>67</td><td></td><td></td><td>64</td><td></td><td></td><td></td><td></td><td></td><td>59</td><td>58</td><td></td><td></td><td></td><td></td><td>54</td></tr> <tr><td></td><td></td><td></td><td></td><td></td><td></td><td></td><td></td><td>46</td><td>45</td><td>44</td><td></td><td></td><td></td><td></td><td>39</td><td>38</td><td></td><td></td><td></td><td></td><td>17</td></tr> <tr><td></td><td></td><td>73</td><td></td><td>32</td><td></td><td>30</td><td>29</td><td>28</td><td>27</td><td></td><td></td><td></td><td></td><td>23</td><td>22</td><td></td><td></td><td></td><td></td><td></td><td>1</td></tr> </table>					68	67			64						59	58					54									46	45	44					39	38					17			73		32		30	29	28	27					23	22						1																						
				68	67			64						59	58					54																																																																										
								46	45	44					39	38					17																																																																									
		73		32		30	29	28	27					23	22						1																																																																									
AVAILABLE	NOT APPLICABLE	34566-5193	G	0	A	BLACK	<table border="1"> <tr><td></td><td></td><td>70</td><td>69</td><td></td><td></td><td></td><td></td><td></td><td></td><td>63</td><td>62</td><td>61</td><td>60</td><td></td><td>58</td><td>57</td><td>56</td><td>55</td><td>54</td><td>53</td></tr> <tr><td>52</td><td>51</td><td></td><td>49</td><td></td><td></td><td></td><td></td><td></td><td></td><td>44</td><td>43</td><td>42</td><td>41</td><td></td><td></td><td></td><td>37</td><td>36</td><td></td><td>34</td></tr> <tr><td></td><td></td><td></td><td></td><td>32</td><td></td><td></td><td></td><td>29</td><td>28</td><td>27</td><td>26</td><td></td><td></td><td></td><td></td><td></td><td></td><td></td><td>19</td><td>18</td><td>17</td></tr> <tr><td></td><td></td><td>73</td><td></td><td>16</td><td>15</td><td></td><td></td><td>13</td><td>12</td><td>11</td><td>10</td><td></td><td></td><td></td><td></td><td></td><td></td><td></td><td>3</td><td>2</td><td>1</td></tr> </table>			70	69							63	62	61	60		58	57	56	55	54	53	52	51		49							44	43	42	41				37	36		34					32				29	28	27	26								19	18	17			73		16	15			13	12	11	10								3	2	1	
		70	69							63	62	61	60		58	57	56	55	54	53																																																																										
52	51		49							44	43	42	41				37	36		34																																																																										
				32				29	28	27	26								19	18	17																																																																									
		73		16	15			13	12	11	10								3	2	1																																																																									
AVAILABLE	NOT APPLICABLE	34566-5213	G	0	A	BLACK	<table border="1"> <tr><td>72</td><td>71</td><td>70</td><td>69</td><td>68</td><td>67</td><td>66</td><td>65</td><td>64</td><td>63</td><td>62</td><td>61</td><td>60</td><td>59</td><td></td><td></td><td></td><td></td><td>55</td><td>54</td><td>53</td></tr> <tr><td>52</td><td></td><td></td><td>49</td><td>48</td><td></td><td></td><td></td><td></td><td>44</td><td>43</td><td>42</td><td>41</td><td>40</td><td>39</td><td></td><td></td><td></td><td></td><td>35</td><td>34</td><td>33</td></tr> <tr><td></td><td></td><td></td><td></td><td>32</td><td></td><td></td><td></td><td>29</td><td>27</td><td></td><td>25</td><td>24</td><td>23</td><td></td><td></td><td></td><td></td><td></td><td>19</td><td>18</td><td>17</td></tr> <tr><td></td><td></td><td>73</td><td></td><td>16</td><td></td><td></td><td></td><td>13</td><td>12</td><td>11</td><td></td><td>9</td><td>8</td><td>7</td><td>6</td><td>5</td><td>4</td><td>3</td><td>2</td><td>1</td><td></td></tr> </table>	72	71	70	69	68	67	66	65	64	63	62	61	60	59					55	54	53	52			49	48					44	43	42	41	40	39					35	34	33					32				29	27		25	24	23						19	18	17			73		16				13	12	11		9	8	7	6	5	4	3	2	1	
72	71	70	69	68	67	66	65	64	63	62	61	60	59					55	54	53																																																																										
52			49	48					44	43	42	41	40	39					35	34	33																																																																									
				32				29	27		25	24	23						19	18	17																																																																									
		73		16				13	12	11		9	8	7	6	5	4	3	2	1																																																																										
AVAILABLE	NOT APPLICABLE	34566-5223	G	0	C	BLUE	<table border="1"> <tr><td>72</td><td>70</td><td></td><td></td><td>67</td><td>66</td><td></td><td></td><td></td><td>63</td><td>62</td><td></td><td></td><td>59</td><td></td><td></td><td>57</td><td></td><td></td><td></td><td>53</td></tr> <tr><td>52</td><td>51</td><td></td><td></td><td>48</td><td>46</td><td></td><td></td><td>44</td><td></td><td>42</td><td></td><td>40</td><td>39</td><td></td><td></td><td></td><td></td><td></td><td></td><td>34</td><td>33</td></tr> <tr><td></td><td></td><td></td><td></td><td>32</td><td>30</td><td></td><td></td><td>27</td><td>26</td><td>25</td><td></td><td></td><td></td><td></td><td></td><td>22</td><td>21</td><td></td><td></td><td></td><td></td></tr> <tr><td></td><td></td><td>73</td><td></td><td>15</td><td>14</td><td></td><td></td><td></td><td></td><td>10</td><td>9</td><td></td><td></td><td></td><td></td><td>6</td><td>5</td><td>4</td><td></td><td></td><td></td></tr> </table>	72	70			67	66				63	62			59			57				53	52	51			48	46			44		42		40	39							34	33					32	30			27	26	25						22	21							73		15	14					10	9					6	5	4			
72	70			67	66				63	62			59			57				53																																																																										
52	51			48	46			44		42		40	39							34	33																																																																									
				32	30			27	26	25						22	21																																																																													
		73		15	14					10	9					6	5	4																																																																												
AVAILABLE	NOT APPLICABLE	34566-5233	G	0	C	BLUE	<table border="1"> <tr><td>72</td><td>70</td><td></td><td></td><td>68</td><td>67</td><td>66</td><td></td><td></td><td>63</td><td>62</td><td></td><td></td><td>59</td><td></td><td></td><td>57</td><td>56</td><td>55</td><td>54</td><td>53</td></tr> <tr><td>52</td><td>51</td><td></td><td></td><td>48</td><td>47</td><td>46</td><td></td><td></td><td>44</td><td></td><td>42</td><td>40</td><td>39</td><td>38</td><td></td><td></td><td></td><td></td><td></td><td>34</td><td>33</td></tr> <tr><td></td><td></td><td></td><td></td><td>32</td><td>30</td><td></td><td></td><td></td><td></td><td>26</td><td>25</td><td></td><td></td><td></td><td></td><td>22</td><td>21</td><td></td><td>19</td><td>18</td><td></td></tr> <tr><td></td><td></td><td>73</td><td></td><td>15</td><td>14</td><td></td><td></td><td></td><td></td><td>10</td><td>9</td><td></td><td></td><td></td><td></td><td>6</td><td>5</td><td>4</td><td>3</td><td></td><td></td></tr> </table>	72	70			68	67	66			63	62			59			57	56	55	54	53	52	51			48	47	46			44		42	40	39	38						34	33					32	30					26	25					22	21		19	18				73		15	14					10	9					6	5	4	3		
72	70			68	67	66			63	62			59			57	56	55	54	53																																																																										
52	51			48	47	46			44		42	40	39	38						34	33																																																																									
				32	30					26	25					22	21		19	18																																																																										
		73		15	14					10	9					6	5	4	3																																																																											
AVAILABLE	NOT APPLICABLE	34566-5243	G	0	C	BLUE	<table border="1"> <tr><td>72</td><td>71</td><td>70</td><td>69</td><td>68</td><td>67</td><td>66</td><td>65</td><td></td><td>63</td><td>62</td><td>61</td><td></td><td>59</td><td>58</td><td>57</td><td>56</td><td>55</td><td>54</td><td>53</td></tr> <tr><td>51</td><td>50</td><td>49</td><td>48</td><td></td><td></td><td>46</td><td>45</td><td>44</td><td>43</td><td>42</td><td>41</td><td>40</td><td>39</td><td>38</td><td></td><td>36</td><td>35</td><td>34</td><td>33</td></tr> <tr><td></td><td></td><td></td><td></td><td>31</td><td>30</td><td>29</td><td>28</td><td>27</td><td>26</td><td>25</td><td></td><td></td><td></td><td></td><td>22</td><td>21</td><td>20</td><td>19</td><td>18</td><td>17</td></tr> <tr><td></td><td></td><td>73</td><td></td><td>16</td><td>15</td><td>14</td><td></td><td></td><td></td><td></td><td>9</td><td>7</td><td>6</td><td>5</td><td>4</td><td>3</td><td>2</td><td>1</td><td></td><td></td></tr> </table>	72	71	70	69	68	67	66	65		63	62	61		59	58	57	56	55	54	53	51	50	49	48			46	45	44	43	42	41	40	39	38		36	35	34	33					31	30	29	28	27	26	25					22	21	20	19	18	17			73		16	15	14					9	7	6	5	4	3	2	1							
72	71	70	69	68	67	66	65		63	62	61		59	58	57	56	55	54	53																																																																											
51	50	49	48			46	45	44	43	42	41	40	39	38		36	35	34	33																																																																											
				31	30	29	28	27	26	25					22	21	20	19	18	17																																																																										
		73		16	15	14					9	7	6	5	4	3	2	1																																																																												
AVAILABLE	NOT APPLICABLE	34566-5253	G	0	B	ST.GRAY	<table border="1"> <tr><td></td><td></td><td></td><td></td><td></td><td></td><td>67</td><td>66</td><td></td><td></td><td>63</td><td></td><td></td><td></td><td>59</td><td>58</td><td>57</td><td>56</td><td>55</td><td>54</td><td>53</td></tr> <tr><td></td><td></td><td>50</td><td>49</td><td>48</td><td></td><td></td><td>46</td><td>45</td><td>43</td><td></td><td></td><td></td><td></td><td>39</td><td>38</td><td>37</td><td>36</td><td>35</td><td>34</td><td>33</td></tr> <tr><td></td><td></td><td></td><td></td><td></td><td></td><td></td><td></td><td>29</td><td>27</td><td></td><td></td><td></td><td></td><td>23</td><td>22</td><td>21</td><td></td><td></td><td></td><td>18</td></tr> <tr><td></td><td></td><td>73</td><td></td><td></td><td></td><td>16</td><td>15</td><td>14</td><td>13</td><td></td><td></td><td></td><td></td><td>8</td><td>7</td><td>6</td><td>5</td><td>4</td><td>3</td><td></td><td></td></tr> </table>							67	66			63				59	58	57	56	55	54	53			50	49	48			46	45	43					39	38	37	36	35	34	33									29	27					23	22	21				18			73				16	15	14	13					8	7	6	5	4	3				
						67	66			63				59	58	57	56	55	54	53																																																																										
		50	49	48			46	45	43					39	38	37	36	35	34	33																																																																										
								29	27					23	22	21				18																																																																										
		73				16	15	14	13					8	7	6	5	4	3																																																																											
AVAILABLE	NOT APPLICABLE	34566-5263	G	0	B	ST.GRAY	<table border="1"> <tr><td>72</td><td>71</td><td>70</td><td></td><td>68</td><td>67</td><td>66</td><td></td><td></td><td></td><td>62</td><td>61</td><td>60</td><td>59</td><td>58</td><td>57</td><td>56</td><td>55</td><td>54</td><td>53</td></tr> <tr><td>52</td><td>51</td><td>50</td><td></td><td>48</td><td>47</td><td>46</td><td></td><td></td><td></td><td>42</td><td>41</td><td>40</td><td>39</td><td>38</td><td>37</td><td>36</td><td>35</td><td>34</td><td>33</td></tr> <tr><td></td><td></td><td></td><td></td><td>32</td><td>31</td><td>30</td><td>29</td><td>28</td><td>27</td><td></td><td>25</td><td>24</td><td></td><td></td><td></td><td></td><td></td><td></td><td></td><td>17</td></tr> <tr><td></td><td></td><td>73</td><td></td><td>16</td><td>15</td><td>14</td><td>13</td><td></td><td></td><td>10</td><td>8</td><td></td><td></td><td></td><td></td><td></td><td></td><td></td><td></td><td>2</td><td>1</td></tr> </table>	72	71	70		68	67	66				62	61	60	59	58	57	56	55	54	53	52	51	50		48	47	46				42	41	40	39	38	37	36	35	34	33					32	31	30	29	28	27		25	24								17			73		16	15	14	13			10	8									2	1				
72	71	70		68	67	66				62	61	60	59	58	57	56	55	54	53																																																																											
52	51	50		48	47	46				42	41	40	39	38	37	36	35	34	33																																																																											
				32	31	30	29	28	27		25	24								17																																																																										
		73		16	15	14	13			10	8									2	1																																																																									
AVAILABLE	NOT APPLICABLE	34566-5273	G	0	A	BLACK	<table border="1"> <tr><td></td><td></td><td>70</td><td>69</td><td></td><td></td><td></td><td></td><td></td><td></td><td>63</td><td>62</td><td>61</td><td>60</td><td></td><td>58</td><td>57</td><td>56</td><td>55</td><td>54</td><td>53</td></tr> <tr><td>52</td><td>51</td><td></td><td>49</td><td></td><td></td><td></td><td></td><td></td><td></td><td>44</td><td>43</td><td>42</td><td>41</td><td></td><td></td><td></td><td>37</td><td>36</td><td></td><td>34</td></tr> <tr><td></td><td></td><td></td><td></td><td>32</td><td></td><td></td><td></td><td>29</td><td>28</td><td>27</td><td>26</td><td></td><td></td><td></td><td>23</td><td></td><td></td><td></td><td></td><td>19</td><td>18</td></tr> <tr><td></td><td></td><td>73</td><td></td><td>16</td><td>15</td><td></td><td></td><td>13</td><td>12</td><td>11</td><td>10</td><td>9</td><td>8</td><td></td><td></td><td></td><td></td><td></td><td>3</td><td></td><td></td></tr> </table>			70	69							63	62	61	60		58	57	56	55	54	53	52	51		49							44	43	42	41				37	36		34					32				29	28	27	26				23					19	18			73		16	15			13	12	11	10	9	8						3			
		70	69							63	62	61	60		58	57	56	55	54	53																																																																										
52	51		49							44	43	42	41				37	36		34																																																																										
				32				29	28	27	26				23					19	18																																																																									
		73		16	15			13	12	11	10	9	8						3																																																																											

ENTER DESCRIPTION IEC NO. UAU2014-0376 DRAWN BY CHKD: APPR:VKOSHY 2013/09/05 2013/09/06	QUALITY SYMBOLS	GENERAL TOLERANCES (UNLESS SPECIFIED)	DIMENSION STYLE	SCALE	DESIGN UNITS	THIRD ANGLE PROJECTION
	∇=0 ∇=0 ∇=0	mm INCH 4 PLACES ± --- ± --- 3 PLACES ± --- ± --- 2 PLACES ± --- ± --- 1 PLACE ± --- ± --- 0 PLACE ± --- ± ---	MM ONLY	1:1	METRIC	DRAWN BY DATE SKRA JENDRANA 2011/02/14 CHECKED BY DATE MVANSLAMBROU 2011/02/14 APPROVED BY DATE
	ANGULAR ± --- DRAFT WHERE APPLICABLE MUST REMAIN WITHIN DIMENSIONS	MATERIAL NO.	DOCUMENT NO.	MX123 66/73/80CKT HRNS CONN ASSY molex		
	SEE BOM	SD-34566-001	59 OF 68	THIS DRAWING CONTAINS INFORMATION THAT IS PROPRIETARY TO MOLEX INCORPORATED AND SHOULD NOT BE USED WITHOUT WRITTEN PERMISSION		

STATUS	GM PART #	MATERIAL #	PART/MATERIAL REVISION	WIRE DRESS OPTION	KEY OPTION Fp	COLOR (TPA) Fp	NUMBERS INDICATE CAVITIES OPEN FOR CIRCUITS Fp																																																																				
AVAILABLE	NOT APPLICABLE	34566-5283	G	0	C	BLUE	<table border="1"> <tr><td>72</td><td>70</td><td>68</td><td>67</td><td>66</td><td></td><td>63</td><td>62</td><td></td><td>59</td><td>57</td><td>56</td><td>55</td><td>54</td><td>53</td></tr> <tr><td>52</td><td>51</td><td></td><td>48</td><td>47</td><td>46</td><td>44</td><td>42</td><td></td><td>40</td><td>39</td><td></td><td></td><td>34</td><td>33</td></tr> <tr><td></td><td>73</td><td></td><td></td><td>32</td><td>30</td><td></td><td></td><td>26</td><td>25</td><td></td><td>22</td><td>21</td><td>19</td><td>18</td></tr> <tr><td></td><td></td><td></td><td></td><td>15</td><td>14</td><td></td><td></td><td>10</td><td>9</td><td></td><td>6</td><td>5</td><td>4</td><td>3</td></tr> </table>	72	70	68	67	66		63	62		59	57	56	55	54	53	52	51		48	47	46	44	42		40	39			34	33		73			32	30			26	25		22	21	19	18					15	14			10	9		6	5	4	3								
72	70	68	67	66		63	62		59	57	56	55	54	53																																																													
52	51		48	47	46	44	42		40	39			34	33																																																													
	73			32	30			26	25		22	21	19	18																																																													
				15	14			10	9		6	5	4	3																																																													
AVAILABLE	NOT APPLICABLE	34566-5293	G	0	A	BLACK	<table border="1"> <tr><td></td><td>70</td><td>69</td><td></td><td></td><td></td><td>63</td><td>62</td><td>61</td><td>60</td><td></td><td>58</td><td>57</td><td>56</td><td>55</td><td>54</td><td>53</td></tr> <tr><td>52</td><td>51</td><td>49</td><td></td><td></td><td></td><td>44</td><td>43</td><td>42</td><td>41</td><td>40</td><td></td><td></td><td>37</td><td>36</td><td>34</td><td></td></tr> <tr><td></td><td>73</td><td></td><td>32</td><td></td><td>29</td><td>28</td><td>27</td><td>26</td><td></td><td></td><td></td><td></td><td></td><td>19</td><td>18</td><td>17</td></tr> <tr><td></td><td></td><td></td><td>16</td><td>15</td><td>13</td><td>12</td><td>11</td><td>10</td><td></td><td></td><td></td><td></td><td></td><td>3</td><td>2</td><td>1</td></tr> </table>		70	69				63	62	61	60		58	57	56	55	54	53	52	51	49				44	43	42	41	40			37	36	34			73		32		29	28	27	26						19	18	17				16	15	13	12	11	10						3	2	1
	70	69				63	62	61	60		58	57	56	55	54	53																																																											
52	51	49				44	43	42	41	40			37	36	34																																																												
	73		32		29	28	27	26						19	18	17																																																											
			16	15	13	12	11	10						3	2	1																																																											
AVAILABLE	NOT APPLICABLE	34566-5313	G	0	C	BLUE	<table border="1"> <tr><td>72</td><td>70</td><td>68</td><td>67</td><td>66</td><td></td><td>63</td><td>62</td><td></td><td>59</td><td>57</td><td>56</td><td>55</td><td>54</td><td>53</td></tr> <tr><td>52</td><td>51</td><td></td><td>48</td><td>47</td><td>46</td><td>44</td><td>42</td><td></td><td>40</td><td>39</td><td>38</td><td>37</td><td>36</td><td>34</td><td>33</td></tr> <tr><td></td><td>73</td><td></td><td>32</td><td>30</td><td></td><td>27</td><td>26</td><td>25</td><td>24</td><td></td><td>22</td><td>21</td><td>19</td><td>18</td></tr> <tr><td></td><td></td><td></td><td>15</td><td>14</td><td></td><td></td><td>10</td><td>9</td><td>8</td><td></td><td>6</td><td>5</td><td>4</td><td>3</td><td>2</td></tr> </table>	72	70	68	67	66		63	62		59	57	56	55	54	53	52	51		48	47	46	44	42		40	39	38	37	36	34	33		73		32	30		27	26	25	24		22	21	19	18				15	14			10	9	8		6	5	4	3	2						
72	70	68	67	66		63	62		59	57	56	55	54	53																																																													
52	51		48	47	46	44	42		40	39	38	37	36	34	33																																																												
	73		32	30		27	26	25	24		22	21	19	18																																																													
			15	14			10	9	8		6	5	4	3	2																																																												
AVAILABLE	NOT APPLICABLE	34566-5323	G	0	G	BLUE	<table border="1"> <tr><td>80</td><td>78</td><td>77</td><td>75</td><td>74</td><td>73</td><td>72</td><td>70</td><td>69</td><td>67</td><td>65</td><td>64</td><td>63</td><td>62</td><td></td><td></td></tr> <tr><td>60</td><td>58</td><td>57</td><td>55</td><td>54</td><td>52</td><td>51</td><td>50</td><td>49</td><td>47</td><td>45</td><td>44</td><td>43</td><td>42</td><td></td><td></td></tr> <tr><td>40</td><td>38</td><td>37</td><td></td><td></td><td></td><td>33</td><td>32</td><td>31</td><td></td><td>27</td><td>26</td><td>25</td><td>24</td><td></td><td></td></tr> <tr><td>20</td><td>18</td><td>17</td><td></td><td></td><td></td><td></td><td>10</td><td>9</td><td>8</td><td></td><td>6</td><td>5</td><td>4</td><td>3</td><td>2</td><td>1</td></tr> </table>	80	78	77	75	74	73	72	70	69	67	65	64	63	62			60	58	57	55	54	52	51	50	49	47	45	44	43	42			40	38	37				33	32	31		27	26	25	24			20	18	17					10	9	8		6	5	4	3	2	1			
80	78	77	75	74	73	72	70	69	67	65	64	63	62																																																														
60	58	57	55	54	52	51	50	49	47	45	44	43	42																																																														
40	38	37				33	32	31		27	26	25	24																																																														
20	18	17					10	9	8		6	5	4	3	2	1																																																											
AVAILABLE	NOT APPLICABLE	34566-5333	G	0	A	BLACK	<table border="1"> <tr><td>72</td><td>71</td><td>70</td><td>68</td><td>67</td><td>66</td><td>65</td><td>64</td><td>63</td><td>62</td><td>60</td><td>59</td><td></td><td>56</td><td></td><td>53</td></tr> <tr><td>51</td><td></td><td>49</td><td>48</td><td>47</td><td>46</td><td>45</td><td>44</td><td>43</td><td></td><td>41</td><td>40</td><td></td><td></td><td></td><td></td></tr> <tr><td></td><td>73</td><td></td><td></td><td></td><td>30</td><td>29</td><td>28</td><td></td><td>26</td><td>25</td><td>24</td><td></td><td></td><td>20</td><td></td><td>17</td></tr> <tr><td></td><td></td><td></td><td></td><td></td><td></td><td></td><td>12</td><td>11</td><td></td><td></td><td></td><td></td><td></td><td></td><td></td><td></td></tr> </table>	72	71	70	68	67	66	65	64	63	62	60	59		56		53	51		49	48	47	46	45	44	43		41	40						73				30	29	28		26	25	24			20		17								12	11										
72	71	70	68	67	66	65	64	63	62	60	59		56		53																																																												
51		49	48	47	46	45	44	43		41	40																																																																
	73				30	29	28		26	25	24			20		17																																																											
							12	11																																																																			
AVAILABLE	NOT APPLICABLE	34566-5343	G	0	B	ST.GRAY	<table border="1"> <tr><td></td><td></td><td></td><td>68</td><td>67</td><td></td><td>64</td><td></td><td></td><td></td><td>59</td><td>58</td><td></td><td></td><td>54</td><td></td></tr> <tr><td></td><td></td><td></td><td></td><td>46</td><td>45</td><td></td><td></td><td></td><td></td><td>39</td><td>38</td><td></td><td></td><td></td><td></td></tr> <tr><td></td><td>73</td><td></td><td>32</td><td>30</td><td>29</td><td>28</td><td>27</td><td></td><td></td><td>23</td><td>22</td><td></td><td></td><td></td><td>17</td></tr> <tr><td></td><td></td><td></td><td></td><td></td><td></td><td>12</td><td>10</td><td>8</td><td></td><td>6</td><td></td><td></td><td></td><td></td><td>1</td></tr> </table>				68	67		64				59	58			54						46	45					39	38						73		32	30	29	28	27			23	22				17							12	10	8		6					1				
			68	67		64				59	58			54																																																													
				46	45					39	38																																																																
	73		32	30	29	28	27			23	22				17																																																												
						12	10	8		6					1																																																												
AVAILABLE	NOT APPLICABLE	34566-5353	G	9	B	ST.GRAY	<table border="1"> <tr><td></td><td></td><td></td><td>68</td><td>67</td><td></td><td>64</td><td>63</td><td></td><td>59</td><td>58</td><td></td><td>55</td><td>54</td><td></td></tr> <tr><td></td><td></td><td></td><td></td><td>46</td><td>45</td><td>44</td><td>43</td><td></td><td>39</td><td>38</td><td></td><td>35</td><td>34</td><td></td></tr> <tr><td></td><td>73</td><td></td><td>32</td><td>30</td><td>29</td><td>28</td><td>27</td><td></td><td>23</td><td>22</td><td></td><td>19</td><td>17</td><td></td></tr> <tr><td></td><td></td><td></td><td>15</td><td>13</td><td>12</td><td>10</td><td></td><td></td><td>6</td><td></td><td></td><td></td><td>1</td><td></td></tr> </table>				68	67		64	63		59	58		55	54						46	45	44	43		39	38		35	34			73		32	30	29	28	27		23	22		19	17					15	13	12	10			6				1									
			68	67		64	63		59	58		55	54																																																														
				46	45	44	43		39	38		35	34																																																														
	73		32	30	29	28	27		23	22		19	17																																																														
			15	13	12	10			6				1																																																														
AVAILABLE	NOT APPLICABLE	34566-5363	G	0	C	BLUE	<table border="1"> <tr><td>72</td><td>70</td><td>68</td><td>66</td><td></td><td>63</td><td>62</td><td></td><td>59</td><td>57</td><td></td><td></td><td></td><td>53</td></tr> <tr><td>52</td><td>51</td><td></td><td>48</td><td>47</td><td>46</td><td>44</td><td>42</td><td>40</td><td>39</td><td>38</td><td></td><td></td><td>34</td><td>33</td></tr> <tr><td></td><td>73</td><td></td><td>32</td><td>30</td><td></td><td>26</td><td>25</td><td></td><td>22</td><td>21</td><td></td><td></td><td></td><td></td></tr> <tr><td></td><td></td><td></td><td>15</td><td>14</td><td></td><td>10</td><td>9</td><td></td><td>6</td><td>5</td><td>4</td><td></td><td></td><td></td></tr> </table>	72	70	68	66		63	62		59	57				53	52	51		48	47	46	44	42	40	39	38			34	33		73		32	30		26	25		22	21								15	14		10	9		6	5	4												
72	70	68	66		63	62		59	57				53																																																														
52	51		48	47	46	44	42	40	39	38			34	33																																																													
	73		32	30		26	25		22	21																																																																	
			15	14		10	9		6	5	4																																																																
AVAILABLE	NOT APPLICABLE	34566-5373	G	0	C	BLUE	<table border="1"> <tr><td>72</td><td>70</td><td>68</td><td>66</td><td></td><td>63</td><td>62</td><td></td><td>59</td><td>57</td><td></td><td></td><td></td><td>53</td></tr> <tr><td>52</td><td>51</td><td></td><td>48</td><td>47</td><td>46</td><td>44</td><td>42</td><td>40</td><td>39</td><td></td><td></td><td></td><td>34</td><td>33</td></tr> <tr><td></td><td>73</td><td></td><td>32</td><td>30</td><td></td><td>26</td><td>25</td><td></td><td>22</td><td>21</td><td></td><td></td><td></td><td></td></tr> <tr><td></td><td></td><td></td><td>15</td><td>14</td><td></td><td>10</td><td>9</td><td></td><td>6</td><td></td><td></td><td></td><td></td><td></td></tr> </table>	72	70	68	66		63	62		59	57				53	52	51		48	47	46	44	42	40	39				34	33		73		32	30		26	25		22	21								15	14		10	9		6														
72	70	68	66		63	62		59	57				53																																																														
52	51		48	47	46	44	42	40	39				34	33																																																													
	73		32	30		26	25		22	21																																																																	
			15	14		10	9		6																																																																		

ENTER DESCRIPTION IEC NO. UAU2014-0376 DRAWN BY: CHYKJ APPR: WJOSHY 2013/09/05 2013/09/06	QUALITY SYMBOLS	∇=0 ∇=0 ∇=0	GENERAL TOLERANCES (UNLESS SPECIFIED) mm INCH 4 PLACES ±--- ±--- 3 PLACES ±--- ±--- 2 PLACES ±--- ±--- 1 PLACE ±--- ±--- 0 PLACE ±--- ±--- ANGULAR ±---° DRAFT WHERE APPLICABLE MUST REMAIN WITHIN DIMENSIONS	DIMENSION STYLE MM ONLY	SCALE 1:1	DESIGN UNITS METRIC	THIRD ANGLE PROJECTION
	DRAWN BY: SKRA JENDRANA CHECKED BY: MVANSLAMBROU APPROVED BY:	DATE: 2011/02/14 DATE: 2011/02/14 DATE:	TITLE MX123 66/73/80CKT HRNS CONN ASSY	MATERIAL NO. SEE BOM	DOCUMENT NO. SD-34566-001	SHEET NO. 60 OF 68	THIS DRAWING CONTAINS INFORMATION THAT IS PROPRIETARY TO MOLEX INCORPORATED AND SHOULD NOT BE USED WITHOUT WRITTEN PERMISSION

STATUS	GM PART #	MATERIAL #	PART/MATERIAL REVISION	WIRE DRESS OPTION	KEY OPTION P	COLOR (TPA) P	NUMBERS INDICATE CAVITIES OPEN FOR CIRCUITS P																																																																
AVAILABLE	NOT APPLICABLE	34566-5383	G	0	C	BLUE	<table border="1"> <tr><td>72</td><td>70</td><td>68</td><td>66</td><td>63</td><td>62</td><td>59</td><td>57</td><td>53</td></tr> <tr><td>52</td><td>51</td><td>48</td><td>47</td><td>46</td><td>44</td><td>42</td><td>40</td><td>39</td><td>37</td><td>36</td><td>34</td><td>33</td></tr> <tr><td colspan="2">73</td><td>32</td><td>30</td><td>26</td><td>25</td><td>24</td><td>22</td><td>21</td><td colspan="4"></td></tr> <tr><td colspan="2"></td><td>15</td><td>14</td><td colspan="2"></td><td>10</td><td>9</td><td>8</td><td>6</td><td>5</td><td>4</td><td>2</td></tr> </table>	72	70	68	66	63	62	59	57	53	52	51	48	47	46	44	42	40	39	37	36	34	33	73		32	30	26	25	24	22	21							15	14			10	9	8	6	5	4	2																
72	70	68	66	63	62	59	57	53																																																															
52	51	48	47	46	44	42	40	39	37	36	34	33																																																											
73		32	30	26	25	24	22	21																																																															
		15	14			10	9	8	6	5	4	2																																																											
AVAILABLE	NOT APPLICABLE	34566-5393	G	0	A	BLACK	<table border="1"> <tr><td></td><td>70</td><td>69</td><td></td><td></td><td>63</td><td></td><td></td><td></td><td></td><td>56</td><td>55</td><td>54</td><td>53</td></tr> <tr><td>52</td><td>51</td><td>49</td><td></td><td></td><td>44</td><td>43</td><td>42</td><td>41</td><td></td><td></td><td>36</td><td>34</td><td></td></tr> <tr><td colspan="2">73</td><td>32</td><td></td><td></td><td>28</td><td>26</td><td></td><td></td><td>23</td><td>21</td><td>19</td><td>18</td><td></td></tr> <tr><td colspan="2"></td><td>16</td><td></td><td></td><td>12</td><td>10</td><td></td><td>8</td><td></td><td>5</td><td>3</td><td></td><td></td></tr> </table>		70	69			63					56	55	54	53	52	51	49			44	43	42	41			36	34		73		32			28	26			23	21	19	18				16			12	10		8		5	3										
	70	69			63					56	55	54	53																																																										
52	51	49			44	43	42	41			36	34																																																											
73		32			28	26			23	21	19	18																																																											
		16			12	10		8		5	3																																																												
AVAILABLE	NOT APPLICABLE	34566-5413	G	0	A	BLACK	<table border="1"> <tr><td></td><td>70</td><td>69</td><td></td><td></td><td>63</td><td></td><td></td><td></td><td></td><td>56</td><td>55</td><td>54</td><td>53</td></tr> <tr><td>52</td><td>51</td><td>49</td><td></td><td></td><td>44</td><td>43</td><td>42</td><td>41</td><td></td><td></td><td>36</td><td>34</td><td></td></tr> <tr><td colspan="2">73</td><td>32</td><td></td><td></td><td>28</td><td>26</td><td></td><td></td><td>23</td><td>21</td><td>19</td><td>18</td><td></td></tr> <tr><td colspan="2"></td><td>16</td><td>15</td><td></td><td>12</td><td>10</td><td></td><td>8</td><td></td><td>5</td><td>3</td><td></td><td></td></tr> </table>		70	69			63					56	55	54	53	52	51	49			44	43	42	41			36	34		73		32			28	26			23	21	19	18				16	15		12	10		8		5	3										
	70	69			63					56	55	54	53																																																										
52	51	49			44	43	42	41			36	34																																																											
73		32			28	26			23	21	19	18																																																											
		16	15		12	10		8		5	3																																																												
AVAILABLE	NOT APPLICABLE	34566-5423	G	0	A	BLACK	<table border="1"> <tr><td></td><td>70</td><td>69</td><td></td><td></td><td>63</td><td></td><td></td><td></td><td></td><td>58</td><td>56</td><td>55</td><td>54</td><td>53</td></tr> <tr><td>52</td><td>51</td><td>49</td><td></td><td></td><td>44</td><td>43</td><td>42</td><td>41</td><td></td><td></td><td>36</td><td>34</td><td></td><td></td></tr> <tr><td colspan="2">73</td><td>32</td><td></td><td></td><td>28</td><td>26</td><td></td><td></td><td></td><td></td><td></td><td>19</td><td>18</td><td></td></tr> <tr><td colspan="2"></td><td>16</td><td></td><td></td><td>12</td><td>10</td><td></td><td></td><td></td><td></td><td></td><td>3</td><td></td><td></td></tr> </table>		70	69			63					58	56	55	54	53	52	51	49			44	43	42	41			36	34			73		32			28	26						19	18				16			12	10						3						
	70	69			63					58	56	55	54	53																																																									
52	51	49			44	43	42	41			36	34																																																											
73		32			28	26						19	18																																																										
		16			12	10						3																																																											
AVAILABLE	NOT APPLICABLE	34566-5433	G	9	B	ST.GRAY	<table border="1"> <tr><td></td><td></td><td>68</td><td>67</td><td></td><td>64</td><td></td><td></td><td></td><td>59</td><td>58</td><td></td><td></td><td>54</td><td></td></tr> <tr><td></td><td></td><td></td><td>46</td><td>45</td><td></td><td></td><td></td><td></td><td>39</td><td>38</td><td></td><td></td><td></td><td></td></tr> <tr><td colspan="2">73</td><td>32</td><td>30</td><td>29</td><td>28</td><td>27</td><td></td><td></td><td>23</td><td>22</td><td></td><td></td><td>17</td><td></td></tr> <tr><td colspan="2"></td><td></td><td></td><td></td><td></td><td>10</td><td></td><td></td><td>6</td><td></td><td></td><td></td><td></td><td>1</td></tr> </table>			68	67		64				59	58			54					46	45					39	38					73		32	30	29	28	27			23	22			17								10			6					1				
		68	67		64				59	58			54																																																										
			46	45					39	38																																																													
73		32	30	29	28	27			23	22			17																																																										
						10			6					1																																																									
AVAILABLE	NOT APPLICABLE	34566-5443	G	9	B	ST.GRAY	<table border="1"> <tr><td></td><td></td><td>68</td><td>67</td><td></td><td>64</td><td></td><td></td><td></td><td>59</td><td>58</td><td></td><td></td><td>54</td><td></td></tr> <tr><td></td><td></td><td></td><td>46</td><td>45</td><td></td><td></td><td></td><td></td><td>39</td><td>38</td><td></td><td></td><td></td><td></td></tr> <tr><td colspan="2">73</td><td>32</td><td>30</td><td>29</td><td>28</td><td>27</td><td></td><td></td><td>23</td><td>22</td><td></td><td></td><td>17</td><td></td></tr> <tr><td colspan="2"></td><td></td><td>15</td><td>13</td><td></td><td></td><td>10</td><td></td><td>6</td><td></td><td></td><td></td><td></td><td>1</td></tr> </table>			68	67		64				59	58			54					46	45					39	38					73		32	30	29	28	27			23	22			17					15	13			10		6					1				
		68	67		64				59	58			54																																																										
			46	45					39	38																																																													
73		32	30	29	28	27			23	22			17																																																										
			15	13			10		6					1																																																									
AVAILABLE	NOT APPLICABLE	34566-5453	G	0	B	ST.GRAY	<table border="1"> <tr><td></td><td></td><td>68</td><td>67</td><td></td><td>64</td><td></td><td></td><td></td><td>59</td><td>58</td><td></td><td></td><td>54</td><td></td></tr> <tr><td></td><td></td><td></td><td>46</td><td>45</td><td></td><td></td><td></td><td></td><td>39</td><td>38</td><td></td><td></td><td></td><td></td></tr> <tr><td colspan="2">73</td><td>32</td><td>30</td><td>29</td><td>28</td><td>27</td><td></td><td></td><td>23</td><td>22</td><td></td><td></td><td>17</td><td></td></tr> <tr><td colspan="2"></td><td></td><td>15</td><td>13</td><td></td><td></td><td>10</td><td></td><td>6</td><td></td><td></td><td></td><td></td><td>1</td></tr> </table>			68	67		64				59	58			54					46	45					39	38					73		32	30	29	28	27			23	22			17					15	13			10		6					1				
		68	67		64				59	58			54																																																										
			46	45					39	38																																																													
73		32	30	29	28	27			23	22			17																																																										
			15	13			10		6					1																																																									
AVAILABLE	NOT APPLICABLE	34566-5463	G	0	A	BLACK	<table border="1"> <tr><td>72</td><td>70</td><td></td><td></td><td></td><td>63</td><td></td><td></td><td></td><td></td><td></td><td></td><td></td><td></td><td></td></tr> <tr><td>52</td><td></td><td>49</td><td></td><td></td><td></td><td></td><td></td><td>41</td><td></td><td></td><td></td><td></td><td></td><td></td></tr> <tr><td colspan="2">73</td><td></td><td>31</td><td>30</td><td>28</td><td>27</td><td>26</td><td></td><td>23</td><td></td><td>20</td><td>19</td><td></td><td></td></tr> <tr><td colspan="2"></td><td>16</td><td>15</td><td>14</td><td>12</td><td>10</td><td></td><td></td><td>6</td><td></td><td></td><td></td><td></td><td></td></tr> </table>	72	70				63										52		49						41							73			31	30	28	27	26		23		20	19					16	15	14	12	10			6									
72	70				63																																																																		
52		49						41																																																															
73			31	30	28	27	26		23		20	19																																																											
		16	15	14	12	10			6																																																														
AVAILABLE	NOT APPLICABLE	34566-5473	G	0	A	BLACK	<table border="1"> <tr><td>72</td><td>71</td><td>70</td><td>68</td><td>67</td><td>66</td><td>65</td><td>64</td><td>63</td><td>62</td><td>60</td><td>59</td><td></td><td>56</td><td></td><td>53</td></tr> <tr><td>52</td><td>51</td><td></td><td>48</td><td>47</td><td>46</td><td>45</td><td>44</td><td>43</td><td>42</td><td>41</td><td>40</td><td></td><td></td><td></td><td></td></tr> <tr><td colspan="2">73</td><td></td><td>31</td><td>30</td><td>29</td><td>28</td><td>27</td><td>26</td><td>25</td><td>24</td><td>23</td><td></td><td>20</td><td>19</td><td>17</td></tr> <tr><td colspan="2"></td><td>16</td><td>15</td><td>14</td><td>12</td><td>11</td><td>10</td><td></td><td></td><td></td><td>6</td><td></td><td></td><td></td><td></td></tr> </table>	72	71	70	68	67	66	65	64	63	62	60	59		56		53	52	51		48	47	46	45	44	43	42	41	40					73			31	30	29	28	27	26	25	24	23		20	19	17			16	15	14	12	11	10				6				
72	71	70	68	67	66	65	64	63	62	60	59		56		53																																																								
52	51		48	47	46	45	44	43	42	41	40																																																												
73			31	30	29	28	27	26	25	24	23		20	19	17																																																								
		16	15	14	12	11	10				6																																																												

ENTER DESCRIPTION IEC NO. UAU2014-0376 DRAWN BY: CHYK 2013/09/05 APPR: WOSHY 2013/09/06 DESCRIPTION	QUALITY SYMBOLS	GENERAL TOLERANCES (UNLESS SPECIFIED)	DIMENSION STYLE	SCALE	DESIGN UNITS	THIRD ANGLE PROJECTION
	∇=0 ∇=0 ∇=0	mm INCH 4 PLACES ±--- ±--- 3 PLACES ±--- ±--- 2 PLACES ±--- ±--- 1 PLACE ±--- ±--- 0 PLACE ±--- ±---	MM ONLY	1:1	METRIC	SKRA JENDRANA 2011/02/14 MVANSLAMBROU 2011/02/14
	ANGULAR ±---° DRAFT WHERE APPLICABLE MUST REMAIN WITHIN DIMENSIONS	MATERIAL NO. SEE BOM TABLE DOCUMENT NO. SD-34566-001	TITLE MX123 66/73/80CKT HRNS CONN ASSY molex SHEET NO. 61 OF 68			

STATUS	GM PART #	MATERIAL #	PART/MATERIAL REVISION	WIRE DRESS OPTION	KEY OPTION P	COLOR (TPA) P	NUMBERS INDICATE CAVITIES OPEN FOR CIRCUITS P																																																																		
AVAILABLE	NOT APPLICABLE	34566-5483	G	0	B	ST.GRAY	<table border="1"> <tr><td>72</td><td>70</td><td>68</td><td>66</td><td>64</td><td>63</td><td></td><td>60</td><td>59</td><td></td><td>55</td><td>54</td><td>53</td></tr> <tr><td>52</td><td>50</td><td>48</td><td>46</td><td></td><td></td><td></td><td>40</td><td>39</td><td></td><td>35</td><td>34</td><td>33</td></tr> <tr><td></td><td>73</td><td>32</td><td>31</td><td>30</td><td>29</td><td>28</td><td>27</td><td>26</td><td>25</td><td>24</td><td></td><td>20</td><td>17</td></tr> <tr><td></td><td></td><td>16</td><td></td><td></td><td></td><td></td><td>10</td><td>8</td><td></td><td>5</td><td>4</td><td>2</td><td>1</td></tr> </table>	72	70	68	66	64	63		60	59		55	54	53	52	50	48	46				40	39		35	34	33		73	32	31	30	29	28	27	26	25	24		20	17			16					10	8		5	4	2	1												
72	70	68	66	64	63		60	59		55	54	53																																																													
52	50	48	46				40	39		35	34	33																																																													
	73	32	31	30	29	28	27	26	25	24		20	17																																																												
		16					10	8		5	4	2	1																																																												
AVAILABLE	NOT APPLICABLE	34566-5493	G	0	A	BLACK	<table border="1"> <tr><td>72</td><td>70</td><td>69</td><td></td><td></td><td>63</td><td></td><td>60</td><td>59</td><td>58</td><td>57</td><td>56</td><td>55</td><td>54</td><td>53</td></tr> <tr><td>52</td><td>51</td><td>49</td><td></td><td></td><td>44</td><td>43</td><td>42</td><td>41</td><td>40</td><td></td><td>37</td><td>36</td><td></td><td>34</td></tr> <tr><td></td><td>73</td><td>32</td><td></td><td></td><td>28</td><td>26</td><td>24</td><td></td><td></td><td></td><td></td><td>19</td><td>18</td><td>17</td></tr> <tr><td></td><td></td><td>16</td><td>15</td><td></td><td>12</td><td>10</td><td></td><td></td><td></td><td></td><td></td><td>3</td><td>2</td><td>1</td></tr> </table>	72	70	69			63		60	59	58	57	56	55	54	53	52	51	49			44	43	42	41	40		37	36		34		73	32			28	26	24					19	18	17			16	15		12	10						3	2	1						
72	70	69			63		60	59	58	57	56	55	54	53																																																											
52	51	49			44	43	42	41	40		37	36		34																																																											
	73	32			28	26	24					19	18	17																																																											
		16	15		12	10						3	2	1																																																											
AVAILABLE	NOT APPLICABLE	34566-5513	G	9	B	ST.GRAY	<table border="1"> <tr><td></td><td></td><td>68</td><td>67</td><td></td><td>64</td><td>63</td><td></td><td></td><td></td><td>58</td><td></td><td>55</td><td></td><td></td></tr> <tr><td></td><td></td><td></td><td>46</td><td>45</td><td></td><td>43</td><td></td><td></td><td></td><td>38</td><td></td><td>35</td><td></td><td></td></tr> <tr><td></td><td>73</td><td>32</td><td>30</td><td>29</td><td>28</td><td>27</td><td></td><td></td><td></td><td>22</td><td></td><td>19</td><td></td><td>17</td></tr> <tr><td></td><td></td><td></td><td></td><td></td><td></td><td></td><td>10</td><td></td><td></td><td></td><td></td><td></td><td></td><td>1</td></tr> </table>			68	67		64	63				58		55						46	45		43				38		35				73	32	30	29	28	27				22		19		17								10							1						
		68	67		64	63				58		55																																																													
			46	45		43				38		35																																																													
	73	32	30	29	28	27				22		19		17																																																											
							10							1																																																											
AVAILABLE	NOT APPLICABLE	34566-5523	G	9	A	BLACK	<table border="1"> <tr><td>72</td><td></td><td>69</td><td>67</td><td>66</td><td>65</td><td>63</td><td></td><td>60</td><td></td><td>57</td><td>56</td><td></td><td>53</td></tr> <tr><td></td><td></td><td>49</td><td>47</td><td></td><td>44</td><td>43</td><td>42</td><td>40</td><td></td><td>37</td><td>36</td><td>35</td><td>33</td></tr> <tr><td></td><td>73</td><td>31</td><td>30</td><td>29</td><td>28</td><td>27</td><td>26</td><td>24</td><td></td><td>21</td><td>20</td><td></td><td>17</td></tr> <tr><td></td><td></td><td>16</td><td>15</td><td>14</td><td>13</td><td>11</td><td>10</td><td></td><td></td><td>5</td><td>4</td><td>3</td><td>2</td><td>1</td></tr> </table>	72		69	67	66	65	63		60		57	56		53			49	47		44	43	42	40		37	36	35	33		73	31	30	29	28	27	26	24		21	20		17			16	15	14	13	11	10			5	4	3	2	1									
72		69	67	66	65	63		60		57	56		53																																																												
		49	47		44	43	42	40		37	36	35	33																																																												
	73	31	30	29	28	27	26	24		21	20		17																																																												
		16	15	14	13	11	10			5	4	3	2	1																																																											
AVAILABLE	NOT APPLICABLE	34566-5533	G	9	B	ST.GRAY	<table border="1"> <tr><td></td><td></td><td>68</td><td>67</td><td></td><td>64</td><td></td><td></td><td></td><td>59</td><td>58</td><td></td><td></td><td>54</td></tr> <tr><td></td><td></td><td></td><td>46</td><td>45</td><td></td><td></td><td></td><td></td><td>39</td><td>38</td><td></td><td></td><td></td></tr> <tr><td></td><td>73</td><td>32</td><td>30</td><td>29</td><td>28</td><td>27</td><td></td><td></td><td>23</td><td>22</td><td></td><td></td><td>17</td></tr> <tr><td></td><td></td><td></td><td></td><td></td><td></td><td></td><td>10</td><td>9</td><td>8</td><td>6</td><td></td><td></td><td></td><td>1</td></tr> </table>			68	67		64				59	58			54				46	45					39	38					73	32	30	29	28	27			23	22			17								10	9	8	6				1									
		68	67		64				59	58			54																																																												
			46	45					39	38																																																															
	73	32	30	29	28	27			23	22			17																																																												
							10	9	8	6				1																																																											
AVAILABLE	NOT APPLICABLE	34566-5543	G	9	A	BLACK	<table border="1"> <tr><td></td><td></td><td>68</td><td>67</td><td></td><td>64</td><td></td><td></td><td></td><td>59</td><td>58</td><td></td><td></td><td>54</td></tr> <tr><td></td><td></td><td></td><td>46</td><td>45</td><td></td><td></td><td></td><td></td><td>39</td><td>38</td><td></td><td></td><td></td></tr> <tr><td></td><td>73</td><td>32</td><td>30</td><td>29</td><td>28</td><td>27</td><td></td><td></td><td>23</td><td>22</td><td></td><td></td><td>17</td></tr> <tr><td></td><td></td><td></td><td></td><td></td><td></td><td></td><td>12</td><td>10</td><td>8</td><td>6</td><td></td><td></td><td></td><td>1</td></tr> </table>			68	67		64				59	58			54				46	45					39	38					73	32	30	29	28	27			23	22			17								12	10	8	6				1									
		68	67		64				59	58			54																																																												
			46	45					39	38																																																															
	73	32	30	29	28	27			23	22			17																																																												
							12	10	8	6				1																																																											
AVAILABLE	NOT APPLICABLE	34566-5553	G	9	B	ST.GRAY	<table border="1"> <tr><td></td><td></td><td>68</td><td>67</td><td></td><td>64</td><td></td><td></td><td></td><td>59</td><td>58</td><td></td><td></td><td>54</td></tr> <tr><td></td><td></td><td></td><td>46</td><td>45</td><td></td><td></td><td></td><td></td><td>39</td><td>38</td><td></td><td></td><td></td></tr> <tr><td></td><td>73</td><td>32</td><td>30</td><td>29</td><td>28</td><td>27</td><td></td><td></td><td>23</td><td>22</td><td></td><td></td><td>17</td></tr> <tr><td></td><td></td><td></td><td></td><td></td><td></td><td></td><td>12</td><td>10</td><td>8</td><td>6</td><td></td><td></td><td></td><td>1</td></tr> </table>			68	67		64				59	58			54				46	45					39	38					73	32	30	29	28	27			23	22			17								12	10	8	6				1									
		68	67		64				59	58			54																																																												
			46	45					39	38																																																															
	73	32	30	29	28	27			23	22			17																																																												
							12	10	8	6				1																																																											
AVAILABLE	NOT APPLICABLE	34566-5563	G	0	A	BLACK	<table border="1"> <tr><td>72</td><td>71</td><td>70</td><td>69</td><td></td><td></td><td>64</td><td>63</td><td></td><td>60</td><td>59</td><td>58</td><td>57</td><td>56</td><td>55</td><td>54</td><td>53</td></tr> <tr><td>52</td><td>51</td><td>49</td><td>48</td><td>47</td><td></td><td>45</td><td>44</td><td>43</td><td>42</td><td>41</td><td></td><td>37</td><td>36</td><td></td><td>34</td><td>33</td></tr> <tr><td></td><td>73</td><td>32</td><td></td><td>30</td><td></td><td>28</td><td>26</td><td></td><td></td><td></td><td></td><td></td><td>19</td><td>18</td><td>17</td></tr> <tr><td></td><td></td><td>16</td><td>15</td><td></td><td></td><td>12</td><td>10</td><td></td><td></td><td></td><td></td><td></td><td>3</td><td>2</td><td>1</td></tr> </table>	72	71	70	69			64	63		60	59	58	57	56	55	54	53	52	51	49	48	47		45	44	43	42	41		37	36		34	33		73	32		30		28	26						19	18	17			16	15			12	10						3	2	1
72	71	70	69			64	63		60	59	58	57	56	55	54	53																																																									
52	51	49	48	47		45	44	43	42	41		37	36		34	33																																																									
	73	32		30		28	26						19	18	17																																																										
		16	15			12	10						3	2	1																																																										
AVAILABLE	NOT APPLICABLE	34566-5573	G	0	C	BLUE	<table border="1"> <tr><td>72</td><td>70</td><td>68</td><td>66</td><td></td><td>63</td><td>62</td><td></td><td>59</td><td>58</td><td>57</td><td>56</td><td>55</td><td>53</td></tr> <tr><td>52</td><td>51</td><td>49</td><td>48</td><td>47</td><td>46</td><td>44</td><td>42</td><td>40</td><td>39</td><td>38</td><td>37</td><td>36</td><td>34</td><td>33</td></tr> <tr><td></td><td>73</td><td>32</td><td>30</td><td></td><td></td><td>26</td><td>25</td><td>24</td><td>23</td><td>22</td><td>21</td><td>20</td><td>19</td><td>18</td><td>17</td></tr> <tr><td></td><td></td><td></td><td>15</td><td>14</td><td>13</td><td></td><td>10</td><td>9</td><td>8</td><td>7</td><td>6</td><td>5</td><td>4</td><td>2</td><td>1</td></tr> </table>	72	70	68	66		63	62		59	58	57	56	55	53	52	51	49	48	47	46	44	42	40	39	38	37	36	34	33		73	32	30			26	25	24	23	22	21	20	19	18	17				15	14	13		10	9	8	7	6	5	4	2	1					
72	70	68	66		63	62		59	58	57	56	55	53																																																												
52	51	49	48	47	46	44	42	40	39	38	37	36	34	33																																																											
	73	32	30			26	25	24	23	22	21	20	19	18	17																																																										
			15	14	13		10	9	8	7	6	5	4	2	1																																																										

ENTER DESCRIPTION IEC NO. UAU2014-0376 DRAWN BY CHKD: APPR:VKOSHY 2013/09/05 2013/09/06 DESCRIPTION	QUALITY SYMBOLS	GENERAL TOLERANCES (UNLESS SPECIFIED)	DIMENSION STYLE	SCALE	DESIGN UNITS	THIRD ANGLE PROJECTION
	▽=0	mm INCH	MM ONLY	1:1	METRIC	
	▽=0	4 PLACES ±--- ±---	DRAWN BY SKRA JENDRANA	DATE 2011/02/14	TITLE	MX123
	▽=0	3 PLACES ±--- ±---	CHECKED BY	DATE		66/73/80CKT
▽=0	2 PLACES ±--- ±---	1 PLACE ±--- ±---	APPROVED BY	DATE		HRNS CONN ASSY
▽=0	0 PLACE ±--- ±---	ANGULAR ±---	MATERIAL NO.	DOCUMENT NO.		molex
	DRAFT WHERE APPLICABLE MUST REMAIN WITHIN DIMENSIONS	SEE BOM TABLE				SD-34566-001
						SHEET NO. 62 OF 68

STATUS	GM PART #	MATERIAL #	PART/MATERIAL REVISION	WIRE DRESS OPTION	KEY OPTION FP	COLOR (TPA) FP	NUMBERS INDICATE CAVITIES OPEN FOR CIRCUITS FP																																																																
AVAILABLE	NOT APPLICABLE	34566-5583	G	0	B	ST.GRAY	<table border="1"> <tr><td>72</td><td>70</td><td>68</td><td>66</td><td>64</td><td>63</td><td>60</td><td>59</td><td>55</td><td>54</td><td>53</td></tr> <tr><td>52</td><td>50</td><td>48</td><td>46</td><td></td><td></td><td>40</td><td>39</td><td></td><td>35</td><td>34</td><td>33</td></tr> <tr><td>73</td><td></td><td>32</td><td>31</td><td>30</td><td>29</td><td>28</td><td>27</td><td>26</td><td>25</td><td>24</td><td>23</td><td>20</td><td>17</td></tr> <tr><td></td><td></td><td>16</td><td></td><td></td><td></td><td>10</td><td>8</td><td>7</td><td>5</td><td>4</td><td>2</td><td>1</td><td></td></tr> </table>	72	70	68	66	64	63	60	59	55	54	53	52	50	48	46			40	39		35	34	33	73		32	31	30	29	28	27	26	25	24	23	20	17			16				10	8	7	5	4	2	1														
72	70	68	66	64	63	60	59	55	54	53																																																													
52	50	48	46			40	39		35	34	33																																																												
73		32	31	30	29	28	27	26	25	24	23	20	17																																																										
		16				10	8	7	5	4	2	1																																																											
AVAILABLE	NOT APPLICABLE	34566-5593	G	0	C	BLUE	<table border="1"> <tr><td>72</td><td>70</td><td>68</td><td>66</td><td></td><td>63</td><td>62</td><td>59</td><td>57</td><td>55</td><td>53</td></tr> <tr><td>52</td><td>51</td><td>48</td><td>47</td><td>46</td><td>44</td><td>42</td><td>40</td><td>39</td><td></td><td>34</td><td>33</td></tr> <tr><td>73</td><td></td><td>32</td><td>30</td><td></td><td></td><td>26</td><td>25</td><td>23</td><td>22</td><td>21</td><td></td><td></td></tr> <tr><td></td><td></td><td>15</td><td>14</td><td></td><td></td><td>10</td><td>9</td><td>7</td><td>6</td><td>5</td><td>4</td><td></td><td></td></tr> </table>	72	70	68	66		63	62	59	57	55	53	52	51	48	47	46	44	42	40	39		34	33	73		32	30			26	25	23	22	21					15	14			10	9	7	6	5	4																
72	70	68	66		63	62	59	57	55	53																																																													
52	51	48	47	46	44	42	40	39		34	33																																																												
73		32	30			26	25	23	22	21																																																													
		15	14			10	9	7	6	5	4																																																												
AVAILABLE	NOT APPLICABLE	34566-5613	G	0	C	BLUE	<table border="1"> <tr><td>72</td><td>70</td><td>68</td><td></td><td></td><td>63</td><td>62</td><td>59</td><td>58</td><td>57</td><td></td><td>53</td></tr> <tr><td>52</td><td>51</td><td>48</td><td>47</td><td></td><td>44</td><td>42</td><td>40</td><td>39</td><td>37</td><td>36</td><td>34</td><td>33</td></tr> <tr><td>73</td><td></td><td>32</td><td>30</td><td></td><td></td><td>27</td><td>26</td><td>25</td><td>24</td><td>23</td><td>22</td><td>21</td><td>20</td><td>17</td></tr> <tr><td></td><td></td><td>15</td><td>14</td><td>13</td><td></td><td></td><td>8</td><td>7</td><td>6</td><td>5</td><td>4</td><td>2</td><td>1</td><td></td></tr> </table>	72	70	68			63	62	59	58	57		53	52	51	48	47		44	42	40	39	37	36	34	33	73		32	30			27	26	25	24	23	22	21	20	17			15	14	13			8	7	6	5	4	2	1										
72	70	68			63	62	59	58	57		53																																																												
52	51	48	47		44	42	40	39	37	36	34	33																																																											
73		32	30			27	26	25	24	23	22	21	20	17																																																									
		15	14	13			8	7	6	5	4	2	1																																																										
AVAILABLE	NOT APPLICABLE	34566-5623	G	0	C	BLUE	<table border="1"> <tr><td>72</td><td>70</td><td>68</td><td></td><td></td><td>63</td><td>62</td><td>59</td><td>57</td><td></td><td>53</td></tr> <tr><td>52</td><td>51</td><td>48</td><td>47</td><td></td><td>44</td><td>42</td><td>40</td><td>39</td><td>37</td><td>36</td><td>34</td><td>33</td></tr> <tr><td>73</td><td></td><td>32</td><td>30</td><td></td><td></td><td>27</td><td>26</td><td>25</td><td>24</td><td>23</td><td>22</td><td>21</td><td>20</td><td></td></tr> <tr><td></td><td></td><td>15</td><td>14</td><td>13</td><td></td><td></td><td>8</td><td>7</td><td>6</td><td>5</td><td>4</td><td>2</td><td></td><td></td></tr> </table>	72	70	68			63	62	59	57		53	52	51	48	47		44	42	40	39	37	36	34	33	73		32	30			27	26	25	24	23	22	21	20				15	14	13			8	7	6	5	4	2												
72	70	68			63	62	59	57		53																																																													
52	51	48	47		44	42	40	39	37	36	34	33																																																											
73		32	30			27	26	25	24	23	22	21	20																																																										
		15	14	13			8	7	6	5	4	2																																																											
AVAILABLE	NOT APPLICABLE	34566-5633	G	0	B	ST.GRAY	<table border="1"> <tr><td>72</td><td></td><td></td><td></td><td></td><td></td><td>62</td><td>61</td><td></td><td></td><td></td><td></td><td></td><td></td></tr> <tr><td>52</td><td></td><td></td><td>48</td><td>46</td><td>44</td><td>43</td><td>41</td><td>40</td><td></td><td></td><td></td><td>20</td><td>19</td><td>18</td></tr> <tr><td>73</td><td></td><td></td><td>16</td><td>15</td><td>14</td><td></td><td></td><td></td><td></td><td></td><td></td><td>4</td><td></td><td></td></tr> </table>	72						62	61							52			48	46	44	43	41	40				20	19	18	73			16	15	14							4																						
72						62	61																																																																
52			48	46	44	43	41	40				20	19	18																																																									
73			16	15	14							4																																																											
AVAILABLE	NOT APPLICABLE	34566-5643	G	0	B	ST.GRAY	<table border="1"> <tr><td>72</td><td></td><td></td><td></td><td></td><td></td><td>62</td><td>61</td><td></td><td></td><td></td><td></td><td></td><td></td></tr> <tr><td>52</td><td></td><td></td><td>48</td><td>46</td><td></td><td>43</td><td>41</td><td>40</td><td></td><td></td><td></td><td>20</td><td>19</td><td>18</td></tr> <tr><td>73</td><td></td><td></td><td>16</td><td>15</td><td>14</td><td></td><td></td><td></td><td></td><td></td><td></td><td>4</td><td></td><td></td></tr> </table>	72						62	61							52			48	46		43	41	40				20	19	18	73			16	15	14							4																						
72						62	61																																																																
52			48	46		43	41	40				20	19	18																																																									
73			16	15	14							4																																																											
AVAILABLE	NOT APPLICABLE	34566-5653	G	0	A	BLACK	<table border="1"> <tr><td>72</td><td>71</td><td>70</td><td>69</td><td>68</td><td>66</td><td>65</td><td>64</td><td>63</td><td>61</td><td>60</td><td></td><td>57</td><td>56</td><td>54</td><td>53</td></tr> <tr><td>52</td><td>51</td><td>50</td><td>49</td><td>48</td><td>46</td><td>45</td><td>44</td><td>43</td><td>40</td><td>39</td><td>38</td><td>37</td><td>36</td><td>34</td><td>33</td></tr> <tr><td>73</td><td></td><td></td><td>32</td><td>31</td><td>30</td><td>29</td><td>28</td><td>26</td><td>25</td><td>23</td><td>22</td><td>21</td><td></td><td></td><td>17</td></tr> <tr><td></td><td></td><td></td><td>15</td><td>14</td><td>13</td><td>12</td><td></td><td>9</td><td>7</td><td>6</td><td>5</td><td></td><td></td><td>2</td><td></td></tr> </table>	72	71	70	69	68	66	65	64	63	61	60		57	56	54	53	52	51	50	49	48	46	45	44	43	40	39	38	37	36	34	33	73			32	31	30	29	28	26	25	23	22	21			17				15	14	13	12		9	7	6	5			2	
72	71	70	69	68	66	65	64	63	61	60		57	56	54	53																																																								
52	51	50	49	48	46	45	44	43	40	39	38	37	36	34	33																																																								
73			32	31	30	29	28	26	25	23	22	21			17																																																								
			15	14	13	12		9	7	6	5			2																																																									
AVAILABLE	NOT APPLICABLE	34566-5663	G	0	C	BLUE	<table border="1"> <tr><td></td><td></td><td>69</td><td>67</td><td>66</td><td>64</td><td>62</td><td>60</td><td></td><td>57</td><td>55</td><td>54</td><td></td><td></td></tr> <tr><td>52</td><td>51</td><td>50</td><td>48</td><td>46</td><td>45</td><td>44</td><td>42</td><td></td><td>37</td><td>35</td><td>34</td><td>33</td><td></td></tr> <tr><td>73</td><td></td><td></td><td>32</td><td>31</td><td></td><td>28</td><td>27</td><td>26</td><td></td><td></td><td>19</td><td>18</td><td></td></tr> <tr><td></td><td></td><td></td><td>16</td><td>15</td><td>14</td><td>13</td><td>12</td><td>11</td><td>10</td><td>9</td><td></td><td></td><td></td><td></td></tr> </table>			69	67	66	64	62	60		57	55	54			52	51	50	48	46	45	44	42		37	35	34	33		73			32	31		28	27	26			19	18					16	15	14	13	12	11	10	9											
		69	67	66	64	62	60		57	55	54																																																												
52	51	50	48	46	45	44	42		37	35	34	33																																																											
73			32	31		28	27	26			19	18																																																											
			16	15	14	13	12	11	10	9																																																													
AVAILABLE	NOT APPLICABLE	34566-5673	G	0	C	BLUE	<table border="1"> <tr><td></td><td></td><td>69</td><td>67</td><td>66</td><td>64</td><td></td><td>61</td><td>60</td><td></td><td>57</td><td>54</td><td></td><td></td></tr> <tr><td>52</td><td>51</td><td>50</td><td>49</td><td>48</td><td>46</td><td>45</td><td>44</td><td>41</td><td></td><td>37</td><td>34</td><td>33</td><td></td></tr> <tr><td>73</td><td></td><td></td><td>32</td><td>31</td><td></td><td>28</td><td>27</td><td>25</td><td></td><td></td><td>18</td><td></td><td></td></tr> <tr><td></td><td></td><td></td><td>16</td><td>15</td><td>14</td><td>13</td><td>12</td><td>11</td><td>10</td><td>9</td><td></td><td></td><td></td><td></td></tr> </table>			69	67	66	64		61	60		57	54			52	51	50	49	48	46	45	44	41		37	34	33		73			32	31		28	27	25			18						16	15	14	13	12	11	10	9											
		69	67	66	64		61	60		57	54																																																												
52	51	50	49	48	46	45	44	41		37	34	33																																																											
73			32	31		28	27	25			18																																																												
			16	15	14	13	12	11	10	9																																																													

ENTER DESCRIPTION IEC NO. UAU2014-0376 DRAWN BY CHKD: APPR:VKOSHY 2013/09/05 2013/09/06 DESCRIPTION	QUALITY SYMBOLS	GENERAL TOLERANCES (UNLESS SPECIFIED)	DIMENSION STYLE	SCALE	DESIGN UNITS	THIRD ANGLE PROJECTION	
	∇=0 ∇=0 ∇=0	mm INCH 4 PLACES ± --- ± --- 3 PLACES ± --- ± --- 2 PLACES ± --- ± --- 1 PLACE ± --- ± --- 0 PLACE ± --- ± ---	MM ONLY	1:1	METRIC	DRAWN BY SKRA JENDRANA 2011/02/14 CHECKED BY MVANSLAMBROU 2011/02/14 APPROVED BY	MX123 66/73/80CKT HRNS CONN ASSY molex
	ANGULAR ± --- DRAFT WHERE APPLICABLE MUST REMAIN WITHIN DIMENSIONS	MATERIAL NO. SEE BOM TABLE	DOCUMENT NO. SD-34566-001	SHEET NO. 63 OF 68			
	THIS DRAWING CONTAINS INFORMATION THAT IS PROPRIETARY TO MOLEX INCORPORATED AND SHOULD NOT BE USED WITHOUT WRITTEN PERMISSION						

STATUS	GM PART #	MATERIAL #	PART/MATERIAL REVISION	WIRE DRESS OPTION	KEY OPTION P	COLOR (TPA) P	NUMBERS INDICATE CAVITIES OPEN FOR CIRCUITS P																																																																							
AVAILABLE	NOT APPLICABLE	34566-5783	G	0	C	BLUE	<table border="1"> <tr><td>72</td><td>70</td><td>68</td><td></td><td></td><td></td><td>63</td><td>62</td><td></td><td>59</td><td>57</td><td></td><td>53</td></tr> <tr><td>52</td><td>51</td><td>48</td><td>47</td><td></td><td>44</td><td>42</td><td>40</td><td>39</td><td>37</td><td>36</td><td></td><td>34</td><td>33</td></tr> <tr><td colspan="2">73</td><td>32</td><td>30</td><td></td><td>27</td><td>26</td><td>25</td><td>24</td><td>22</td><td>21</td><td>20</td><td></td><td></td></tr> <tr><td colspan="2"></td><td>15</td><td>14</td><td>13</td><td></td><td></td><td></td><td>8</td><td>6</td><td>5</td><td>4</td><td></td><td>2</td></tr> </table>	72	70	68				63	62		59	57		53	52	51	48	47		44	42	40	39	37	36		34	33	73		32	30		27	26	25	24	22	21	20					15	14	13				8	6	5	4		2																
72	70	68				63	62		59	57		53																																																																		
52	51	48	47		44	42	40	39	37	36		34	33																																																																	
73		32	30		27	26	25	24	22	21	20																																																																			
		15	14	13				8	6	5	4		2																																																																	
AVAILABLE	NOT APPLICABLE	34566-5793	G	0	B	ST.GRAY	<table border="1"> <tr><td>72</td><td>70</td><td>68</td><td>66</td><td></td><td></td><td></td><td></td><td>60</td><td>59</td><td></td><td></td><td>55</td><td>54</td><td>53</td></tr> <tr><td>52</td><td>50</td><td>48</td><td>46</td><td></td><td></td><td></td><td></td><td>40</td><td>39</td><td></td><td></td><td>35</td><td>34</td><td>33</td></tr> <tr><td colspan="2">73</td><td>32</td><td>31</td><td>30</td><td>29</td><td>28</td><td>27</td><td>26</td><td>25</td><td>24</td><td></td><td></td><td></td><td>17</td></tr> <tr><td colspan="2"></td><td>16</td><td></td><td></td><td></td><td></td><td>10</td><td></td><td>8</td><td></td><td></td><td></td><td></td><td>2</td><td>1</td></tr> </table>	72	70	68	66					60	59			55	54	53	52	50	48	46					40	39			35	34	33	73		32	31	30	29	28	27	26	25	24				17			16					10		8					2	1										
72	70	68	66					60	59			55	54	53																																																																
52	50	48	46					40	39			35	34	33																																																																
73		32	31	30	29	28	27	26	25	24				17																																																																
		16					10		8					2	1																																																															
AVAILABLE	NOT APPLICABLE	34566-5813	G	0	B	ST.GRAY	<table border="1"> <tr><td>72</td><td>70</td><td>68</td><td>66</td><td></td><td></td><td></td><td></td><td>60</td><td>59</td><td></td><td></td><td>55</td><td>54</td><td>53</td></tr> <tr><td>52</td><td>50</td><td>48</td><td>46</td><td></td><td></td><td></td><td></td><td>40</td><td>39</td><td></td><td></td><td>35</td><td>34</td><td>33</td></tr> <tr><td colspan="2">73</td><td>32</td><td>31</td><td>30</td><td>29</td><td>28</td><td>27</td><td>26</td><td>25</td><td>24</td><td>23</td><td></td><td>19</td><td>18</td><td>17</td></tr> <tr><td colspan="2"></td><td>16</td><td></td><td></td><td></td><td></td><td>10</td><td></td><td>8</td><td>7</td><td></td><td></td><td></td><td>2</td><td>1</td></tr> </table>	72	70	68	66					60	59			55	54	53	52	50	48	46					40	39			35	34	33	73		32	31	30	29	28	27	26	25	24	23		19	18	17			16					10		8	7				2	1									
72	70	68	66					60	59			55	54	53																																																																
52	50	48	46					40	39			35	34	33																																																																
73		32	31	30	29	28	27	26	25	24	23		19	18	17																																																															
		16					10		8	7				2	1																																																															
AVAILABLE	NOT APPLICABLE	34566-5823	G	0	A	BLACK	<table border="1"> <tr><td>72</td><td>70</td><td></td><td></td><td></td><td></td><td>63</td><td></td><td></td><td></td><td></td><td></td><td></td><td></td><td></td><td></td></tr> <tr><td>52</td><td></td><td>49</td><td></td><td></td><td></td><td>43</td><td>41</td><td></td><td></td><td></td><td></td><td></td><td></td><td></td><td></td></tr> <tr><td colspan="2">73</td><td></td><td>31</td><td>30</td><td>28</td><td>27</td><td>26</td><td></td><td>23</td><td></td><td></td><td>20</td><td>19</td><td></td><td></td></tr> <tr><td colspan="2"></td><td></td><td>16</td><td>15</td><td>14</td><td></td><td>10</td><td></td><td></td><td></td><td>6</td><td></td><td></td><td></td><td></td></tr> </table>	72	70					63										52		49				43	41									73			31	30	28	27	26		23			20	19						16	15	14		10				6											
72	70					63																																																																								
52		49				43	41																																																																							
73			31	30	28	27	26		23			20	19																																																																	
			16	15	14		10				6																																																																			
AVAILABLE	NOT APPLICABLE	34566-5833	G	0	A	BLACK	<table border="1"> <tr><td>72</td><td>70</td><td></td><td></td><td></td><td></td><td>63</td><td></td><td></td><td></td><td></td><td></td><td></td><td></td><td></td><td></td></tr> <tr><td>52</td><td></td><td>49</td><td></td><td></td><td></td><td>43</td><td>41</td><td></td><td></td><td></td><td></td><td></td><td></td><td></td><td></td></tr> <tr><td colspan="2">73</td><td></td><td>31</td><td>30</td><td>28</td><td>27</td><td>26</td><td></td><td>23</td><td></td><td></td><td>20</td><td>19</td><td></td><td></td></tr> <tr><td colspan="2"></td><td></td><td>16</td><td>15</td><td>14</td><td></td><td>12</td><td>10</td><td></td><td></td><td>6</td><td></td><td></td><td></td><td></td></tr> </table>	72	70					63										52		49				43	41									73			31	30	28	27	26		23			20	19						16	15	14		12	10			6											
72	70					63																																																																								
52		49				43	41																																																																							
73			31	30	28	27	26		23			20	19																																																																	
			16	15	14		12	10			6																																																																			
AVAILABLE	NOT APPLICABLE	34566-5843	G	0	H	ST.GRAY	<table border="1"> <tr><td>79</td><td></td><td></td><td></td><td>74</td><td>73</td><td>72</td><td>71</td><td></td><td>68</td><td>67</td><td></td><td>65</td><td>64</td><td>63</td><td>62</td><td>61</td></tr> <tr><td>59</td><td></td><td>57</td><td></td><td>54</td><td>52</td><td></td><td></td><td></td><td></td><td></td><td></td><td></td><td></td><td></td><td>42</td><td>41</td></tr> <tr><td colspan="2">73</td><td>38</td><td></td><td>34</td><td>33</td><td></td><td></td><td>29</td><td>27</td><td>25</td><td></td><td></td><td></td><td></td><td></td><td></td></tr> <tr><td colspan="2"></td><td>18</td><td></td><td>15</td><td>14</td><td></td><td>11</td><td>10</td><td>9</td><td>8</td><td>7</td><td></td><td></td><td></td><td></td><td></td></tr> </table>	79				74	73	72	71		68	67		65	64	63	62	61	59		57		54	52										42	41	73		38		34	33			29	27	25									18		15	14		11	10	9	8	7								
79				74	73	72	71		68	67		65	64	63	62	61																																																														
59		57		54	52										42	41																																																														
73		38		34	33			29	27	25																																																																				
		18		15	14		11	10	9	8	7																																																																			
AVAILABLE	NOT APPLICABLE	34566-5853	G	0	H	ST.GRAY	<table border="1"> <tr><td>79</td><td></td><td></td><td></td><td>74</td><td>73</td><td>72</td><td>71</td><td></td><td>68</td><td>67</td><td></td><td>65</td><td>64</td><td>63</td><td>62</td><td>61</td></tr> <tr><td>59</td><td></td><td>57</td><td></td><td>54</td><td>52</td><td></td><td></td><td></td><td></td><td></td><td></td><td></td><td></td><td></td><td>43</td><td>42</td><td>41</td></tr> <tr><td colspan="2">73</td><td>38</td><td></td><td>33</td><td></td><td></td><td></td><td>29</td><td>27</td><td>25</td><td></td><td></td><td></td><td></td><td></td><td></td><td></td></tr> <tr><td colspan="2"></td><td>18</td><td></td><td>15</td><td>14</td><td></td><td>11</td><td>10</td><td>9</td><td>8</td><td>7</td><td></td><td></td><td></td><td></td><td></td><td></td></tr> </table>	79				74	73	72	71		68	67		65	64	63	62	61	59		57		54	52										43	42	41	73		38		33				29	27	25										18		15	14		11	10	9	8	7						
79				74	73	72	71		68	67		65	64	63	62	61																																																														
59		57		54	52										43	42	41																																																													
73		38		33				29	27	25																																																																				
		18		15	14		11	10	9	8	7																																																																			
AVAILABLE	NOT APPLICABLE	34566-5863	G	0	C	BLUE	<table border="1"> <tr><td>72</td><td>70</td><td></td><td></td><td>66</td><td></td><td>63</td><td>62</td><td></td><td>59</td><td>57</td><td>56</td><td>55</td><td>53</td></tr> <tr><td>52</td><td>51</td><td></td><td></td><td>46</td><td>44</td><td>42</td><td>40</td><td>39</td><td>37</td><td>36</td><td></td><td>34</td><td>33</td></tr> <tr><td colspan="2">73</td><td>32</td><td>30</td><td></td><td></td><td>26</td><td>25</td><td></td><td>22</td><td>21</td><td>19</td><td>18</td><td></td></tr> <tr><td colspan="2"></td><td>15</td><td>14</td><td></td><td></td><td>10</td><td>9</td><td></td><td>6</td><td></td><td>3</td><td></td><td></td></tr> </table>	72	70			66		63	62		59	57	56	55	53	52	51			46	44	42	40	39	37	36		34	33	73		32	30			26	25		22	21	19	18				15	14			10	9		6		3																	
72	70			66		63	62		59	57	56	55	53																																																																	
52	51			46	44	42	40	39	37	36		34	33																																																																	
73		32	30			26	25		22	21	19	18																																																																		
		15	14			10	9		6		3																																																																			
AVAILABLE	NOT APPLICABLE	34566-5873	G	0	B	ST.GRAY	<table border="1"> <tr><td>72</td><td></td><td></td><td>48</td><td>47</td><td>46</td><td>44</td><td>43</td><td>41</td><td>40</td><td></td><td></td><td></td><td></td><td></td><td></td><td></td></tr> <tr><td>52</td><td></td><td></td><td></td><td>30</td><td></td><td></td><td></td><td></td><td></td><td></td><td></td><td>20</td><td>19</td><td>18</td><td></td><td></td></tr> <tr><td colspan="2">73</td><td></td><td>16</td><td>15</td><td>14</td><td></td><td></td><td></td><td></td><td></td><td></td><td>4</td><td></td><td></td><td></td><td></td></tr> </table>	72			48	47	46	44	43	41	40								52				30								20	19	18			73			16	15	14							4																								
72			48	47	46	44	43	41	40																																																																					
52				30								20	19	18																																																																
73			16	15	14							4																																																																		

ENTER DESCRIPTION IEC NO. UAU2014-0376 DRAWN BY: 2013/09/05 CHKD: 2013/09/06 APPR: VKOSHY DESCRIPTION:	QUALITY SYMBOLS ∇=0 ∇=0 ∇=0	GENERAL TOLERANCES (UNLESS SPECIFIED) mm INCH 4 PLACES ±--- ±--- 3 PLACES ±--- ±--- 2 PLACES ±--- ±--- 1 PLACE ±--- ±--- 0 PLACE ±--- ±--- ANGULAR ±--- DRAFT WHERE APPLICABLE MUST REMAIN WITHIN DIMENSIONS	DIMENSION STYLE MM ONLY	SCALE 1:1	DESIGN UNITS METRIC	THIRD ANGLE PROJECTION
	DRAWN BY: SKRA JENDRANA 2011/02/14 CHECKED BY: MVANSLAMBROU 2011/02/14 APPROVED BY:	MATERIAL NO. SEE BOM TABLE DOCUMENT NO. SD-34566-001	SHEET NO. 65 OF 68			

MX123
66/73/80CKT
HRNS CONN ASSY
molex

STATUS	GM PART #	MATERIAL #	PART/MATERIAL REVISION	WIRE DRESS OPTION	KEY OPTION Fp	COLOR (TPA) Fp	NUMBERS INDICATE CAVITIES OPEN FOR CIRCUITS Fp																		
AVAILABLE	NOT APPLICABLE	34566-5993	G	0	A	BLACK	71	70	69	67	66	65	63	62	61	60	58	57	56	55	54	53			
							52	51	50	49	47	45	44	43	42	41	40	39	37	36	35	34			
							73				32	31	30	29	28	27	26	25	24	23	21	20			
											16	15	14	13	12	11	10	9	8	6	5	3	1		
AVAILABLE	NOT APPLICABLE	34566-6013	G	0	B	ST.GRAY			69	67	65			61	60	59	58	57			54	53			
							51	50	49	48	47	46	45	43		40	39	37	37			34	33		
							73								26	24	23	22	21	20			18		
															10	9	8	7	6	5	4				
AVAILABLE	NOT APPLICABLE	34566-6023	G	0	A	BLACK	72	71	70	69	68	67					60	59	58	57	56		54	53	
							52	51	50	49	48	47	45	44	43		40	39	38	37	36	35	34	33	
							73									24	23	22	21	20	19		17		
																10	9	8	7	6	5	4	3	2	1
AVAILABLE	NOT APPLICABLE	34566-6033	G	0	A	BLACK			70	69					63	62	61			58	57	56	55	54	53
							52	51		49					44	43	42	41			37	36		34	
							73													21	19	18			
																				8		5	3		
AVAILABLE	NOT APPLICABLE	34566-6043	G	0	B	ST.GRAY				68	67	66	65	64						58		55			
																				38		35			
							73													22		19		17	
																								1	
AVAILABLE	NOT APPLICABLE	34566-6053	G	0	B	ST.GRAY	72								62	61									
							52			48	47	46			43	41	40								
							73															20	19	18	
																						4		2	
AVAILABLE	NOT APPLICABLE	34566-6063	G	0	C	BLUE			69	67	66	64	62	61	60					57		55	54		
							52	51	50	48	46	45	44	42						37		35	34	33	
							73						28	27	26							19	18	17	
																9									
AVAILABLE	NOT APPLICABLE	34566-6073	G	0	C	BLUE			69	67	66	64	62	61	60					57		54			
							52	51	50	49	48	46	45	44	41					37		34	33		
							73							28	27	25							18	17	
AVAILABLE	NOT APPLICABLE	34566-6083	G	0	C	BLUE	72	70	68	67	66			63	62		59	57						53	
							52	51		48	47	46	44	42	40	39		37	36			34	33		
							73							26	25			22	21						
																					6	5	4	2	

ENTER DESCRIPTION IEC NO. UAU2014-0376 DRAWN BY CHYK APPR:VKOSHY 2013/09/06 DESCRIPTION	QUALITY SYMBOLS	GENERAL TOLERANCES (UNLESS SPECIFIED)	DIMENSION STYLE	SCALE	DESIGN UNITS	THIRD ANGLE PROJECTION
	▽=0	4 PLACES ± mm ± INCH	MM ONLY	1:1	METRIC	☉
	▽=0	3 PLACES ± mm ± INCH	DRAWN BY SKRA JENDRANA	DATE 2011/02/14	TITLE	
	▽=0	2 PLACES ± mm ± INCH	CHECKED BY	DATE		
	1 PLACE ± mm ± INCH	0 PLACE ± mm ± INCH	APPROVED BY	DATE		
	ANGULAR ± °	DRAFT WHERE APPLICABLE MUST REMAIN WITHIN DIMENSIONS	MATERIAL NO.	DOCUMENT NO.		
			SEE BOM TABLE	SD-34566-001		
			THIS DRAWING CONTAINS INFORMATION THAT IS PROPRIETARY TO MOLEX INCORPORATED AND SHOULD NOT BE USED WITHOUT WRITTEN PERMISSION			

MX123
66/73/80CKT
HRNS CONN ASSY
molex

STATUS	GM PART #	MATERIAL #	PART/MATERIAL REVISION	WIRE DRESS OPTION	KEY OPTION Fp	COLOR (TPA) Fp	NUMBERS INDICATE CAVITIES OPEN FOR CIRCUITS Fp																																																																																
AVAILABLE	NOT APPLICABLE	34566-6093	G	0	B	ST.GRAY	<table border="1"> <tr><td>72</td><td>70</td><td></td><td>67</td><td></td><td></td><td>63</td><td>62</td><td>61</td><td>60</td><td>59</td><td></td><td></td><td></td><td></td><td></td><td></td><td></td><td></td><td></td></tr> <tr><td>52</td><td></td><td></td><td></td><td></td><td></td><td>46</td><td>43</td><td>41</td><td>40</td><td></td><td></td><td></td><td></td><td></td><td></td><td></td><td>20</td><td>19</td><td>18</td></tr> <tr><td></td><td>73</td><td></td><td></td><td></td><td></td><td></td><td>27</td><td></td><td></td><td></td><td></td><td></td><td></td><td></td><td></td><td></td><td>4</td><td></td><td></td></tr> <tr><td></td><td></td><td>16</td><td>14</td><td></td><td></td><td>11</td><td></td><td></td><td></td><td></td><td></td><td></td><td></td><td></td><td></td><td></td><td></td><td></td><td></td></tr> </table>	72	70		67			63	62	61	60	59										52						46	43	41	40								20	19	18		73						27										4					16	14			11													
72	70		67			63	62	61	60	59																																																																													
52						46	43	41	40								20	19	18																																																																				
	73						27										4																																																																						
		16	14			11																																																																																	
AVAILABLE	NOT APPLICABLE	34566-6113	G	0	A	BLACK	<table border="1"> <tr><td>72</td><td>71</td><td>70</td><td>69</td><td>68</td><td>66</td><td>65</td><td>64</td><td>63</td><td>62</td><td>61</td><td>60</td><td></td><td>58</td><td>57</td><td>56</td><td>55</td><td>54</td><td>53</td><td></td></tr> <tr><td>52</td><td>51</td><td>50</td><td>49</td><td>48</td><td>46</td><td>45</td><td>44</td><td>43</td><td>42</td><td>41</td><td>40</td><td>39</td><td>38</td><td>37</td><td>36</td><td></td><td>34</td><td>33</td><td></td></tr> <tr><td></td><td>73</td><td></td><td>32</td><td>31</td><td>30</td><td>29</td><td>28</td><td>27</td><td>26</td><td>25</td><td>23</td><td>22</td><td>21</td><td>20</td><td>19</td><td>18</td><td></td><td></td><td></td></tr> <tr><td></td><td></td><td>16</td><td>15</td><td>14</td><td>13</td><td>12</td><td>11</td><td>10</td><td>9</td><td>8</td><td>7</td><td>6</td><td>5</td><td>4</td><td>3</td><td>2</td><td></td><td></td><td></td></tr> </table>	72	71	70	69	68	66	65	64	63	62	61	60		58	57	56	55	54	53		52	51	50	49	48	46	45	44	43	42	41	40	39	38	37	36		34	33			73		32	31	30	29	28	27	26	25	23	22	21	20	19	18						16	15	14	13	12	11	10	9	8	7	6	5	4	3	2			
72	71	70	69	68	66	65	64	63	62	61	60		58	57	56	55	54	53																																																																					
52	51	50	49	48	46	45	44	43	42	41	40	39	38	37	36		34	33																																																																					
	73		32	31	30	29	28	27	26	25	23	22	21	20	19	18																																																																							
		16	15	14	13	12	11	10	9	8	7	6	5	4	3	2																																																																							
AVAILABLE	NOT APPLICABLE	34566-6123	G	0	C	BLUE	<table border="1"> <tr><td></td><td></td><td></td><td>69</td><td>67</td><td>66</td><td></td><td>64</td><td></td><td>62</td><td></td><td>60</td><td></td><td></td><td>57</td><td></td><td></td><td></td><td>54</td><td></td></tr> <tr><td>52</td><td>51</td><td>50</td><td></td><td>48</td><td>46</td><td>45</td><td>44</td><td></td><td>42</td><td></td><td></td><td></td><td></td><td>37</td><td></td><td></td><td></td><td>34</td><td>33</td></tr> <tr><td></td><td>73</td><td></td><td></td><td></td><td></td><td></td><td>28</td><td>27</td><td>26</td><td></td><td></td><td></td><td></td><td></td><td></td><td></td><td></td><td></td><td></td></tr> <tr><td></td><td></td><td>16</td><td>15</td><td>14</td><td>13</td><td>12</td><td>11</td><td>10</td><td>9</td><td>8</td><td>7</td><td></td><td></td><td></td><td></td><td></td><td></td><td></td><td></td></tr> </table>				69	67	66		64		62		60			57				54		52	51	50		48	46	45	44		42					37				34	33		73						28	27	26													16	15	14	13	12	11	10	9	8	7								
			69	67	66		64		62		60			57				54																																																																					
52	51	50		48	46	45	44		42					37				34	33																																																																				
	73						28	27	26																																																																														
		16	15	14	13	12	11	10	9	8	7																																																																												
AVAILABLE	NOT APPLICABLE	34566-6133	G	9	C	BLUE	<table border="1"> <tr><td>72</td><td>70</td><td></td><td>68</td><td>67</td><td></td><td></td><td></td><td>63</td><td>62</td><td></td><td></td><td></td><td>59</td><td></td><td>57</td><td></td><td></td><td></td><td>53</td></tr> <tr><td>52</td><td>51</td><td></td><td>48</td><td>47</td><td></td><td></td><td>44</td><td></td><td>42</td><td></td><td>40</td><td>39</td><td>38</td><td>37</td><td>36</td><td></td><td>34</td><td>33</td><td></td></tr> <tr><td></td><td>73</td><td></td><td>32</td><td>30</td><td></td><td></td><td></td><td>26</td><td>25</td><td>24</td><td></td><td></td><td>22</td><td>21</td><td></td><td></td><td></td><td></td><td></td></tr> <tr><td></td><td></td><td>16</td><td>15</td><td>14</td><td></td><td></td><td></td><td></td><td>9</td><td>8</td><td>7</td><td>6</td><td>5</td><td>4</td><td>3</td><td>2</td><td></td><td></td><td></td></tr> </table>	72	70		68	67				63	62				59		57				53	52	51		48	47			44		42		40	39	38	37	36		34	33			73		32	30				26	25	24			22	21								16	15	14					9	8	7	6	5	4	3	2			
72	70		68	67				63	62				59		57				53																																																																				
52	51		48	47			44		42		40	39	38	37	36		34	33																																																																					
	73		32	30				26	25	24			22	21																																																																									
		16	15	14					9	8	7	6	5	4	3	2																																																																							
GS AVAILABLE	NOT APPLICABLE	34566-6173	G	9	B	ST.GRAY	<table border="1"> <tr><td></td><td></td><td></td><td></td><td>67</td><td>66</td><td></td><td></td><td></td><td></td><td></td><td></td><td></td><td></td><td></td><td></td><td></td><td></td><td></td><td></td></tr> <tr><td></td><td></td><td></td><td></td><td>48</td><td>47</td><td></td><td></td><td></td><td>41</td><td></td><td></td><td></td><td></td><td></td><td></td><td></td><td></td><td></td><td></td></tr> <tr><td></td><td>73</td><td></td><td>32</td><td>31</td><td>30</td><td>29</td><td></td><td>27</td><td>26</td><td>25</td><td>24</td><td></td><td>22</td><td>21</td><td></td><td>19</td><td>18</td><td>17</td><td></td></tr> <tr><td></td><td></td><td>16</td><td>15</td><td>14</td><td>13</td><td></td><td>11</td><td>10</td><td>9</td><td>8</td><td>7</td><td>6</td><td>5</td><td>4</td><td>3</td><td>2</td><td></td><td></td><td>1</td></tr> </table>					67	66																			48	47				41												73		32	31	30	29		27	26	25	24		22	21		19	18	17				16	15	14	13		11	10	9	8	7	6	5	4	3	2			1
				67	66																																																																																		
				48	47				41																																																																														
	73		32	31	30	29		27	26	25	24		22	21		19	18	17																																																																					
		16	15	14	13		11	10	9	8	7	6	5	4	3	2			1																																																																				
GS AVAILABLE	NOT APPLICABLE	34566-6183	G	9	A	BLACK	<table border="1"> <tr><td></td><td></td><td></td><td></td><td>48</td><td>47</td><td></td><td></td><td></td><td>41</td><td></td><td></td><td></td><td></td><td></td><td></td><td></td><td></td><td></td><td></td></tr> <tr><td></td><td>73</td><td></td><td>32</td><td>31</td><td>30</td><td>29</td><td></td><td>27</td><td>26</td><td>25</td><td>24</td><td></td><td>22</td><td>21</td><td></td><td>19</td><td>18</td><td>17</td><td></td></tr> <tr><td></td><td></td><td>16</td><td>15</td><td>14</td><td>13</td><td></td><td>11</td><td>10</td><td>9</td><td>8</td><td>7</td><td>6</td><td>5</td><td>4</td><td>3</td><td>2</td><td></td><td></td><td>1</td></tr> </table>					48	47				41												73		32	31	30	29		27	26	25	24		22	21		19	18	17				16	15	14	13		11	10	9	8	7	6	5	4	3	2			1																				
				48	47				41																																																																														
	73		32	31	30	29		27	26	25	24		22	21		19	18	17																																																																					
		16	15	14	13		11	10	9	8	7	6	5	4	3	2			1																																																																				
GS AVAILABLE	NOT APPLICABLE	34566-6193	G	9	B	ST.GRAY	<table border="1"> <tr><td>72</td><td>71</td><td>70</td><td>69</td><td>68</td><td>67</td><td>66</td><td>65</td><td>64</td><td></td><td>62</td><td>61</td><td>60</td><td>59</td><td>58</td><td>57</td><td>56</td><td>55</td><td>54</td><td></td></tr> <tr><td>52</td><td>51</td><td>50</td><td>49</td><td></td><td></td><td>46</td><td></td><td>44</td><td></td><td>41</td><td>40</td><td></td><td></td><td>38</td><td>37</td><td>36</td><td></td><td></td><td></td></tr> <tr><td></td><td>73</td><td></td><td>32</td><td>31</td><td>30</td><td>29</td><td>28</td><td>27</td><td>26</td><td>25</td><td>24</td><td></td><td></td><td>21</td><td>20</td><td></td><td></td><td>18</td><td>17</td></tr> <tr><td></td><td></td><td>16</td><td>15</td><td>14</td><td>13</td><td>12</td><td></td><td>10</td><td>9</td><td>8</td><td>7</td><td>6</td><td>5</td><td>4</td><td>3</td><td>2</td><td></td><td></td><td></td></tr> </table>	72	71	70	69	68	67	66	65	64		62	61	60	59	58	57	56	55	54		52	51	50	49			46		44		41	40			38	37	36					73		32	31	30	29	28	27	26	25	24			21	20			18	17			16	15	14	13	12		10	9	8	7	6	5	4	3	2			
72	71	70	69	68	67	66	65	64		62	61	60	59	58	57	56	55	54																																																																					
52	51	50	49			46		44		41	40			38	37	36																																																																							
	73		32	31	30	29	28	27	26	25	24			21	20			18	17																																																																				
		16	15	14	13	12		10	9	8	7	6	5	4	3	2																																																																							

ENTER DESCRIPTION IEC NO. UAU2014-0376 DRAWN BY CHYKZ APPR:VKOSHY 2013/09/05 2013/09/06 DESCRIPTION GS	QUALITY SYMBOLS ∇=0 ∇=0 ∇=0	GENERAL TOLERANCES (UNLESS SPECIFIED) mm INCH 4 PLACES # --- # --- 3 PLACES # --- # --- 2 PLACES # --- # --- 1 PLACE # --- # --- 0 PLACE # --- # --- ANGULAR ± ---° DRAFT WHERE APPLICABLE MUST REMAIN WITHIN DIMENSIONS	DIMENSION STYLE MM ONLY	SCALE 1:1	DESIGN UNITS METRIC	THIRD ANGLE PROJECTION
	DRAWN BY SKRA JENDRANA 2011/02/14 CHECKED BY MVANSLAMBROU 2011/02/14 APPROVED BY		MATERIAL NO. SEE BOM TABLE DOCUMENT NO. SD-34566-001		TITLE MX123 66/73/80CKT HRNS CONN ASSY molex	
	SHEET NO. 68 OF 68		THIS DRAWING CONTAINS INFORMATION THAT IS PROPRIETARY TO MOLEX INCORPORATED AND SHOULD NOT BE USED WITHOUT WRITTEN PERMISSION			