

9 8 7 6 5 4 3 2 1

E

D

C

B

A

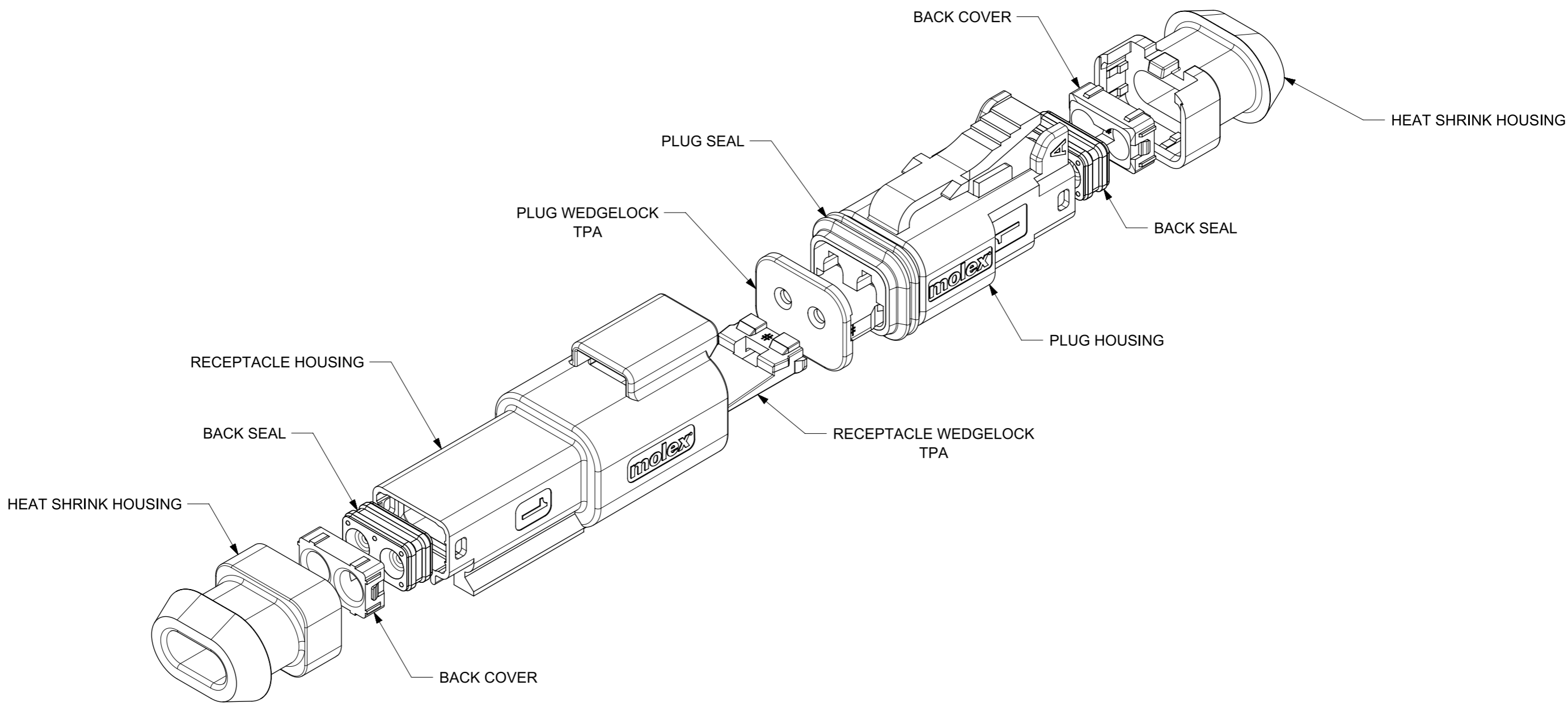

NOTES
 1. SEE SHEETS 2 TO 7 FOR UNSPECIFIED NOTES, DIMENSIONS AND PART NUMBERS

THIS DRAWING CONTAINS INFORMATION THAT IS PROPRIETARY TO MOLEX INCORPORATED AND SHOULD NOT BE USED WITHOUT WRITTEN PERMISSION												
SUPERSEDING SD-93443-0010 EC NO: 100661 DRWN: KREILLY CHK'D: FDUGGAN APPR: JDWALLACE	2015/06/12	2015/09/13	2015/09/15	QUALITY SYMBOLS ∇ = 0 ∇ = 0 ∇ = 0 ▼ = 0 ∇ = 0 ☒ = 0 ■ = 0 ∇ = 0	GENERAL TOLERANCES (UNLESS SPECIFIED) ANGULAR TOL ± 2.0 ° 4 PLACES ± 3 PLACES ± 2 PLACES ± 0.1 1 PLACE ± 0.2 0 PLACES ± DRAFT WHERE APPLICABLE MUST REMAIN WITHIN DIMENSIONS		DIMENSION UNITS MM		SCALE 2:1			
	DRWN BY	DATE					KREILLY 2015/06/12		PRODUCT CUSTOMER DRAWING			
	CHK'D BY	DATE					FDUGGAN 2015/09/13					
	APP'R BY	DATE					JDWALLACE 2015/09/15		SERIES	MATERIAL NUMBER	CUSTOMER	
	A		REV						A3		THIRD ANGLE PROJECTION	
						DOCUMENT NUMBER 934430010		DOC TYPE PSD	DOC PART 000	SHEET NUMBER 1 OF 9		

9 8 7 6 5 4 3 2 1

2CCT RECEPTACLE CONNECTOR

2CCT RECEPTACLE CONNECTOR WITH HEATSHRINK HOUSING ULTRASONICALLY WELDED IN PLACE

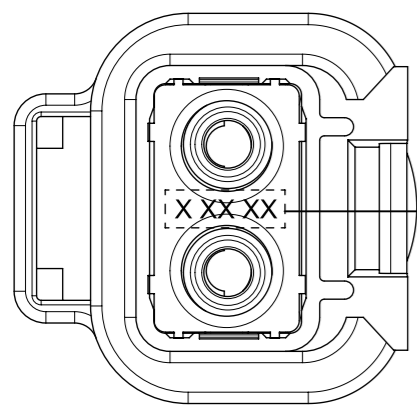
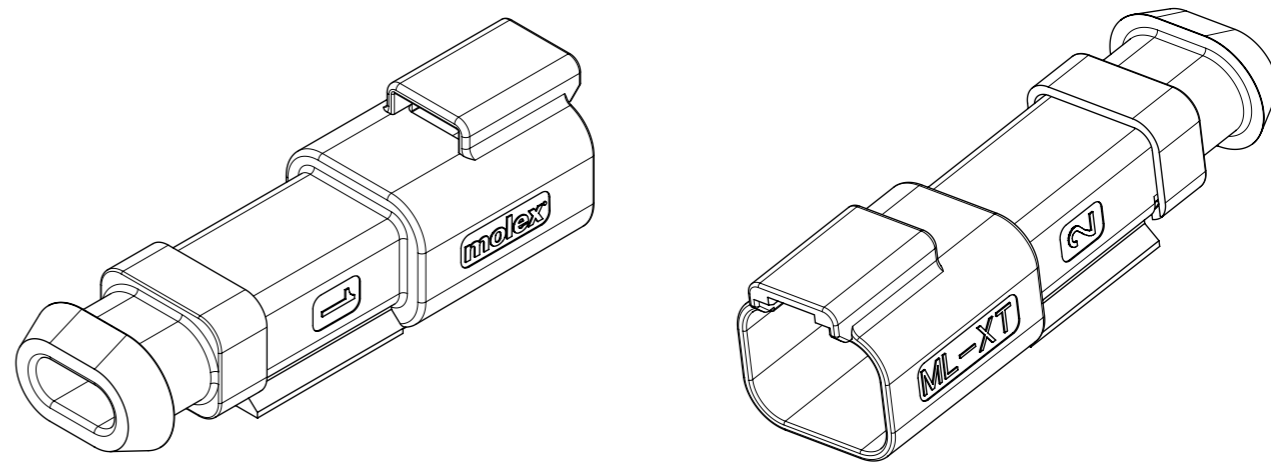
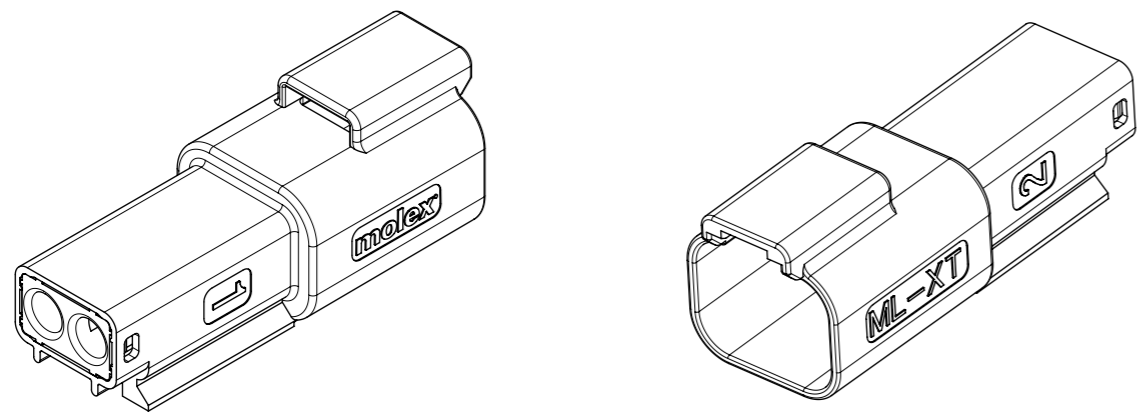

DATE CODE: X XX XX
 X — DAY: 1-7
 X — WEEK: 01 - 52
 X — YEAR: 00 - 99
 X —
 EXAMPLE: 11315 = DAY 1, WEEK 13, YEAR 15
 i.e. 23rd OF MARCH 2015

(ROTATED 90°)
 DETAIL A
 SCALE 3:1

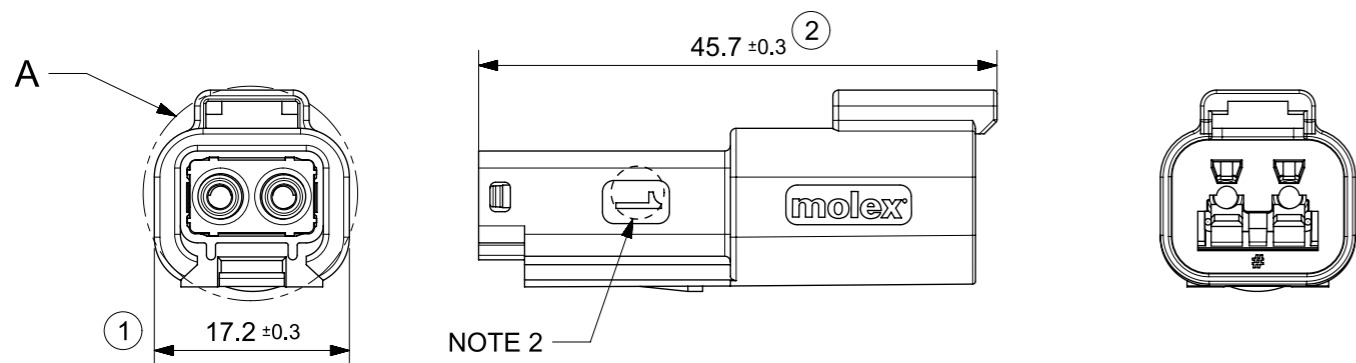

NOTE 2

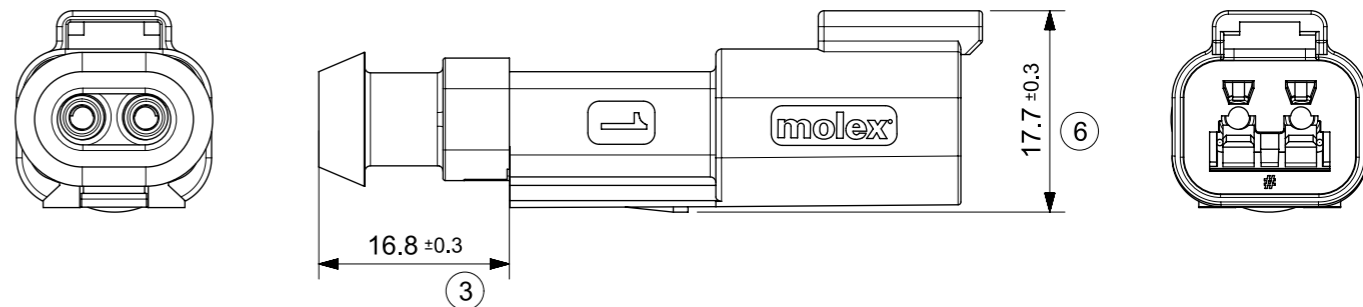
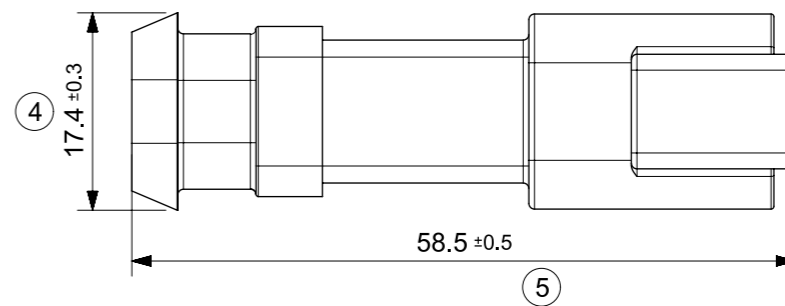

NOTES:

- MATERIAL
 HOUSING: NYLON 30%GF
 BACK SEAL: HIGH CONSISTENCY RUBBER
- CIRCUIT IDENTIFICATION
- JACKET RANGE LARGE = 2.7mm TO 3.6mm (SEAL COLOUR: LIGHT BLUE)
 JACKET RANGE SMALL = 1.4mm TO 2.7mm (SEAL COLOUR: BURNT ORANGE)
- SEE SHEET 3 FOR FINAL PART NUMBER DESIGNATION
- SEE PS-93443-001 FOR PRODUCT SPECIFICATION
- SEE PK-93443-001 FOR PACKAGING SPECIFICATION
 LAST INSPECTION NUMBER: 6
 INSPECTION NUMBERS 1-50 RESERVED FOR SHEET 2

THIS DRAWING CONTAINS INFORMATION THAT IS PROPRIETARY TO MOLEX INCORPORATED AND SHOULD NOT BE USED WITHOUT WRITTEN PERMISSION

SUPERSEDING SD-93443-0010 EC NO: 100661 DRWN: KREILLY CHK'D: FDUGGAN APPR: JDWALLACE	2015/06/12 2015/09/13 2015/09/15	QUALITY SYMBOLS ▽ = 0 ▽ = 0 ▽ = 0 ▼ = 0 ▽ = 0 ☒ = 0 ■ = 0 ▽ = 0	GENERAL TOLERANCES (UNLESS SPECIFIED) ANGULAR TOL ± 2.0 ° 4 PLACES ± 3 PLACES ± 2 PLACES ± 0.1 1 PLACE ± 0.2 0 PLACES ±	DIMENSION UNITS MM	SCALE 1.5:1				
	DRWN BY KREILLY	DATE 2015/06/12	CHK'D BY FDUGGAN	DATE 2015/09/13	2CCT ML-XT CV CONNECTOR				
	APPR BY JDWALLACE	DATE 2015/09/15	DRAWING SIZE A3	THIRD ANGLE PROJECTION					SERIES 93443
	A	REV	DRAFT WHERE APPLICABLE MUST REMAIN WITHIN DIMENSIONS	DIMENSION UNITS MM	SCALE 1.5:1	DOCUMENT NUMBER 934430010	DOC TYPE PSD	DOC PART 000	SHEET NUMBER 2 OF 9

2CCT RECEPTACLE CONNECTOR

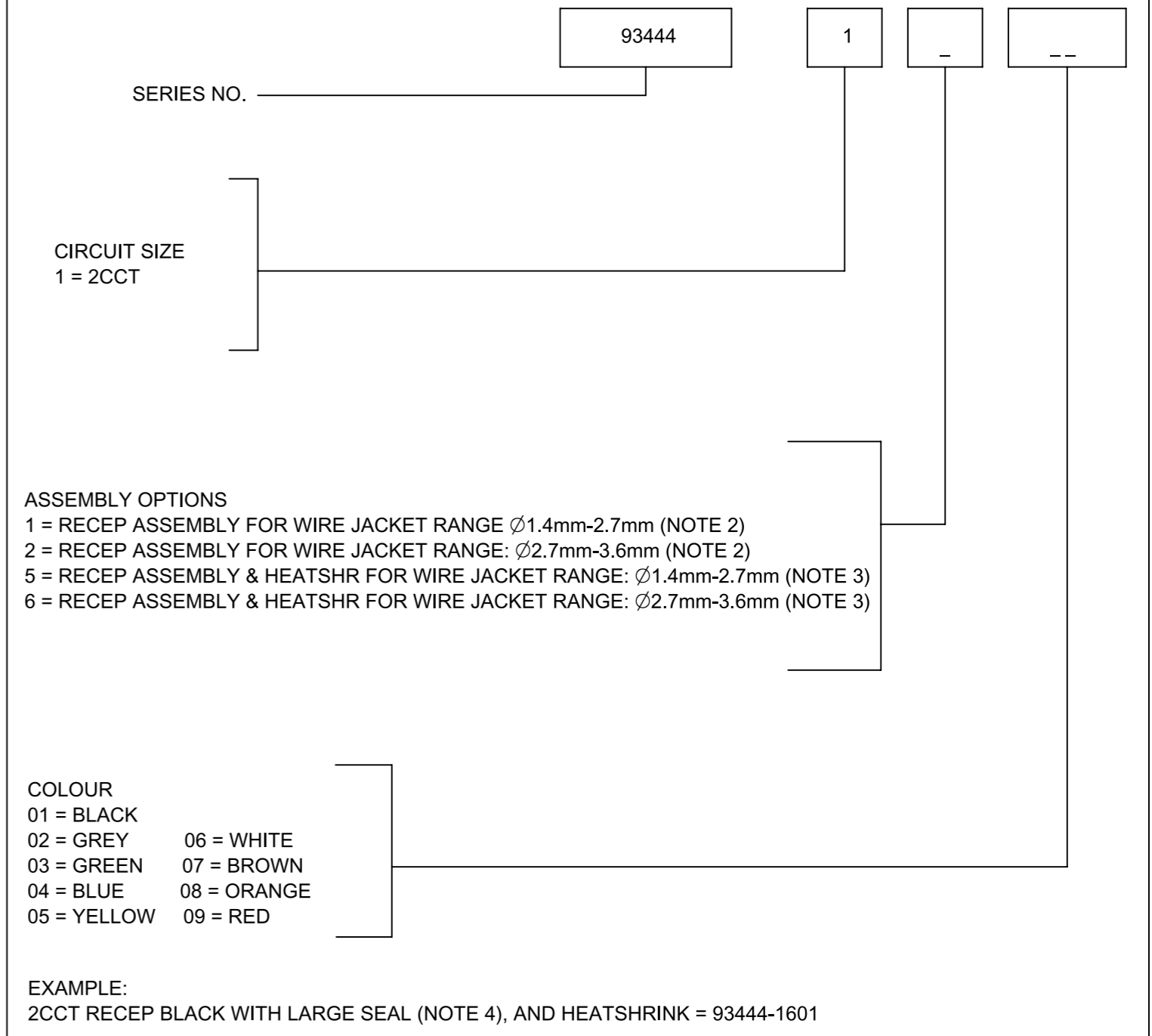

SERIES NO. 93444

CIRCUIT SIZE
1 = 2CCT

- ASSEMBLY OPTIONS
- 1 = RECEP ASSEMBLY FOR WIRE JACKET RANGE \varnothing 1.4mm-2.7mm (NOTE 2)
 - 2 = RECEP ASSEMBLY FOR WIRE JACKET RANGE: \varnothing 2.7mm-3.6mm (NOTE 2)
 - 5 = RECEP ASSEMBLY & HEATSHR FOR WIRE JACKET RANGE: \varnothing 1.4mm-2.7mm (NOTE 3)
 - 6 = RECEP ASSEMBLY & HEATSHR FOR WIRE JACKET RANGE: \varnothing 2.7mm-3.6mm (NOTE 3)

- COLOUR
- 01 = BLACK
 - 02 = GREY
 - 03 = GREEN
 - 04 = BLUE
 - 05 = YELLOW
 - 06 = WHITE
 - 07 = BROWN
 - 08 = ORANGE
 - 09 = RED

EXAMPLE:
2CCT RECEP BLACK WITH LARGE SEAL (NOTE 4), AND HEATSHRINK = 93444-1601

- Notes:
1. SEE SHEET 2 FOR UNSPECIFIED NOTES AND DIMENSIONS
 2. BACK COVER HOUSING COLOUR: BLACK
 3. HEATSHRINK HOUSING COLOUR: BLACK
 4. JACKET RANGE LARGE = 2.7mm TO 3.6mm (SEAL COLOUR: LIGHT BLUE)
JACKET RANGE SMALL = 1.4mm TO 2.7mm (SEAL COLOUR: BURNT ORANGE)

THIS DRAWING CONTAINS INFORMATION THAT IS PROPRIETARY TO MOLEX INCORPORATED AND SHOULD NOT BE USED WITHOUT WRITTEN PERMISSION											
SUPERSEDING SD-93443-0010 EC NO: 100661 DRWN: KREILLY CHK'D: FDUGGAN APPR: JDWALLACE	2015/06/12	2015/09/13	2015/09/15	QUALITY SYMBOLS ∇ = 0 ∇ = 0 ∇ = 0 ▼ = 0 ∇ = 0 ☒ = 0 ■ = 0 ∇ = 0	GENERAL TOLERANCES (UNLESS SPECIFIED)		DIMENSION UNITS		SCALE		
	ANGULAR TOL ± 2.0 °		MM		2:1		2CCT ML-XT CV CONNECTOR				
	4 PLACES ±	DRWN BY			DATE						
	3 PLACES ±	KREILLY			2015/06/12		PRODUCT CUSTOMER DRAWING				
	2 PLACES ± 0.1	CHK'D BY			DATE						
1 PLACE ± 0.2	FDUGGAN		2015/09/13		SERIES		MATERIAL NUMBER		CUSTOMER		
0 PLACES ±	APPR BY		DATE		93443		SEE CHART				
DRAFT WHERE APPLICABLE MUST REMAIN WITHIN DIMENSIONS		JDWALLACE		2015/09/15		DOCUMENT NUMBER		DOC TYPE		DOC PART SHEET NUMBER	
		A		REV		A3		PSD		000 3 OF 9	

9 8 7 6 5 4 3 2 1

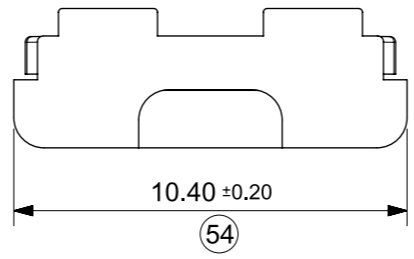
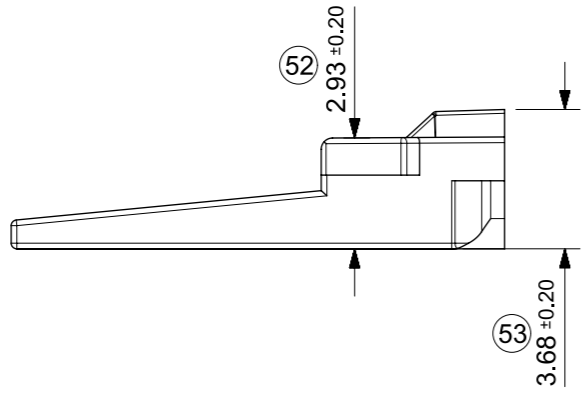
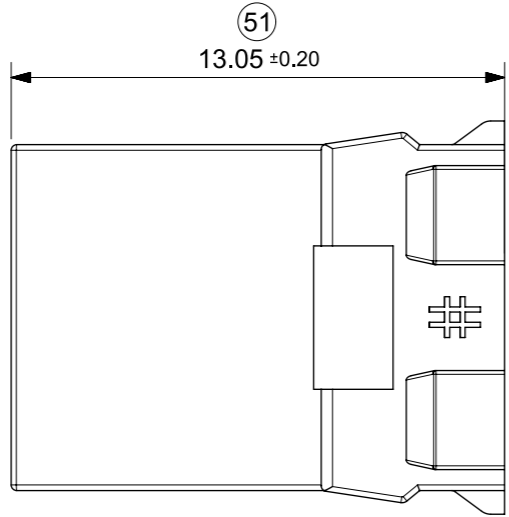
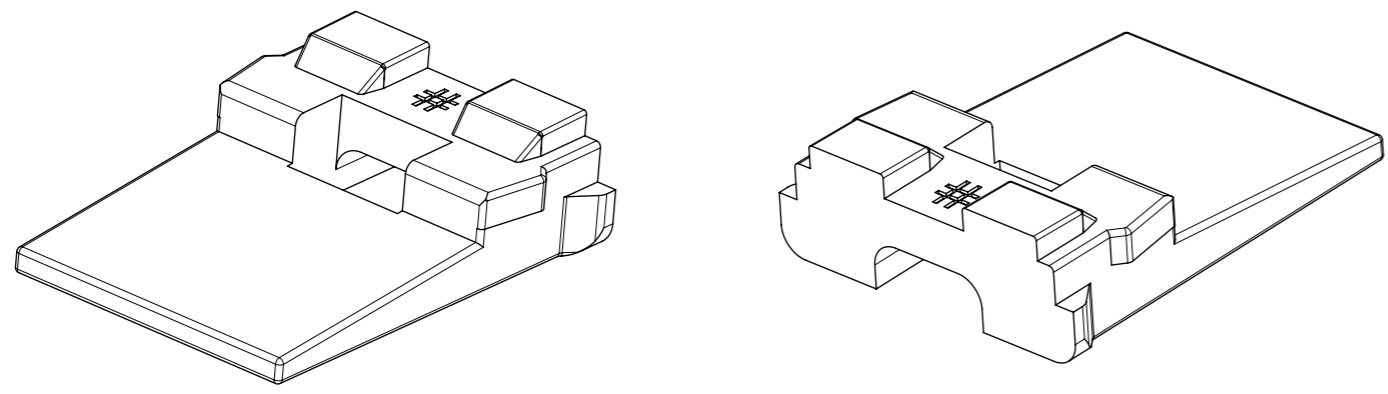

2CCT RECEP. WEDGELOCK

SERIES NO. 93447 1 0 --

CIRCUIT SIZE 1 = 2CCT

COLOUR/KEYING
 03 = GREEN (NO KEY)
 12 = GREY A KEY
 21 = BLACK B KEY
 33 = GREEN C KEY
 47 = BROWN D KEY

NOTES
 1. MATERIAL
 HOUSING: NYLON 30%GF
 2. INSPECTION NUMBERS 51-100
 RESERVED FOR SHEET 4
 3. PART NUMBER 934471003 SHOWN
 LAST INSPECTION NUMBER 54

THIS DRAWING CONTAINS INFORMATION THAT IS PROPRIETARY TO MOLEX INCORPORATED AND SHOULD NOT BE USED WITHOUT WRITTEN PERMISSION													
SUPERSEDING SD-93443-0010 EC NO: 100661 DRWN: KREILLY CHK'D: FDUGGAN APPR: JDWALLACE	2015/06/12	2015/09/13	2015/09/15	QUALITY SYMBOLS □ = 0 ▽ = 0 ▽ = 0 ▽ = 0 ▽ = 0 ▽ = 0 ▽ = 0 ▽ = 0 ▽ = 0 ▽ = 0	GENERAL TOLERANCES (UNLESS SPECIFIED)		DIMENSION UNITS	SCALE					
	ANGULAR TOL ± 2.0 °		MM		5:1								
	4 PLACES ±	3 PLACES ±	2 PLACES ± 0.1		1 PLACE ± 0.2	0 PLACES ±	DRAFT WHERE APPLICABLE MUST REMAIN WITHIN DIMENSIONS	DRWN BY	DATE	2CCT ML-XT CV CONNECTOR			
	DRAFT WHERE APPLICABLE MUST REMAIN WITHIN DIMENSIONS		A3		THIRD ANGLE PROJECTION	KREILLY	2015/06/12						
	REV	APPR	DATE		DATE	DATE	DATE	APPR BY	DATE	PRODUCT CUSTOMER DRAWING			
A	JDWALLACE	2015/09/15	2015/09/15	2015/09/15	2015/09/15	JDWALLACE	2015/09/15	SERIES	MATERIAL NUMBER	CUSTOMER	SEE CHART		
								93443	934430010	934430010	DOC TYPE	DOC PART	SHEET NUMBER
								PSD	000	000			4 OF 9

9 8 7 6 5 4 3 2 1

934471012 (KEY A)
COLOUR GREY

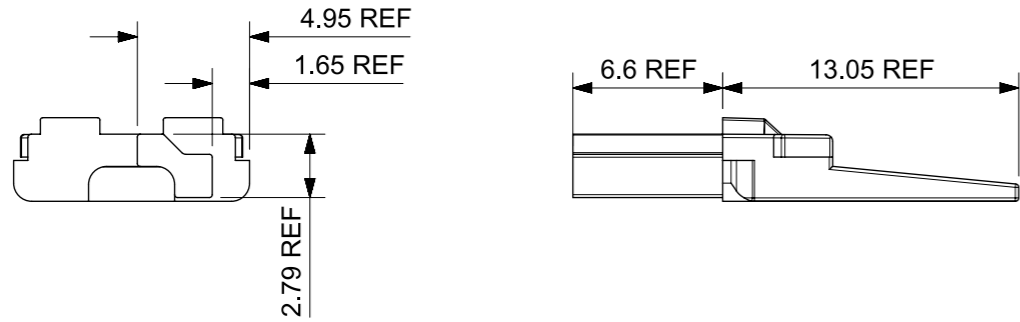
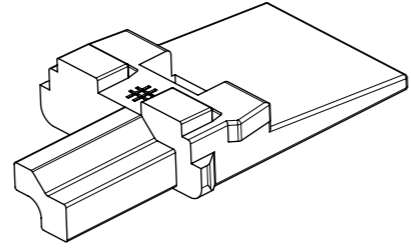

934471021 (KEY B)
COLOUR BLACK

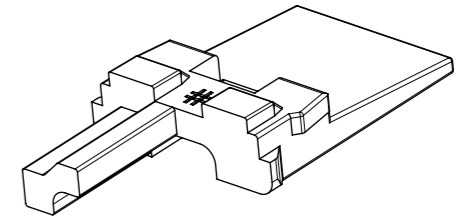

934471033 (KEY C)
COLOUR GREEN

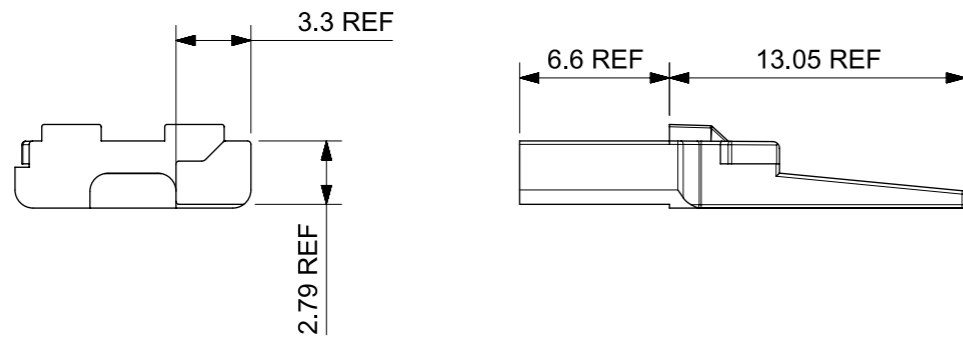
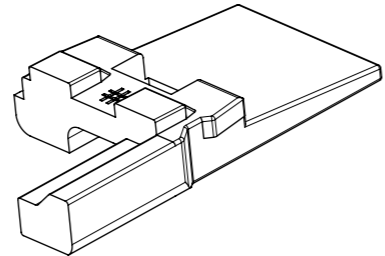

934471047 (KEY D)
COLOUR BROWN

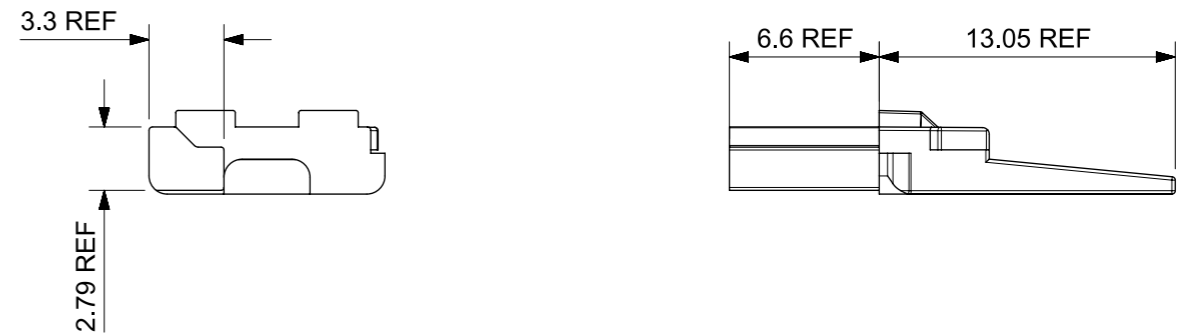
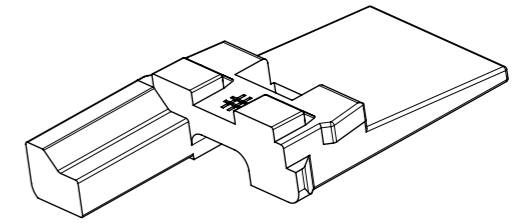

NOTES:
1. MATERIAL PA66 30%GF
2. SEE SHEET 4 FOR UNSPECIFIED NOTES & DIMENSIONS

THIS DRAWING CONTAINS INFORMATION THAT IS PROPRIETARY TO MOLEX INCORPORATED AND SHOULD NOT BE USED WITHOUT WRITTEN PERMISSION

SUPERSEDING SD-93443-0010 EC NO: 100661 DRWN: KREILLY CHK'D: FDUGGAN APPR: JDWALLACE	2015/06/12	2015/09/13	2015/09/15	QUALITY SYMBOLS □ = 0 ▽ = 0 ▽ = 0 ▽ = 0 ▽ = 0 ▽ = 0 ▽ = 0 ▽ = 0 ▽ = 0 ▽ = 0 ▽ = 0	GENERAL TOLERANCES (UNLESS SPECIFIED) ANGULAR TOL ± 2.0 ° 4 PLACES ± 3 PLACES ± 2 PLACES ± 0.1 1 PLACE ± 0.2 0 PLACES ± DRAFT WHERE APPLICABLE MUST REMAIN WITHIN DIMENSIONS	DIMENSION UNITS	SCALE			
	MM		3:1							
	DRWN BY	DATE				PRODUCT CUSTOMER DRAWING				
	KREILLY	2015/06/12								
CHK'D BY	DATE		SERIES	MATERIAL NUMBER	CUSTOMER					
FDUGGAN	2015/09/13		93443							
APPR BY	DATE		DOCUMENT NUMBER	DOC TYPE	DOC PART	SHEET NUMBER				
JDWALLACE	2015/09/15		934430010	PSD	000	5 OF 9				
DRAWING SIZE	THIRD ANGLE PROJECTION									
A3										

2CCT PLUG CONNECTOR

2CCT PLUG CONNECTOR WITH HEATSHRINK HOUSING ULTRA SONICALLY WELDED IN PLACE

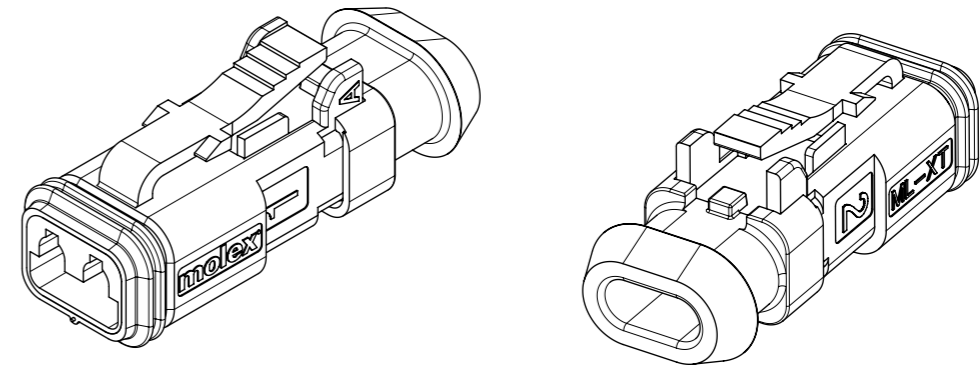
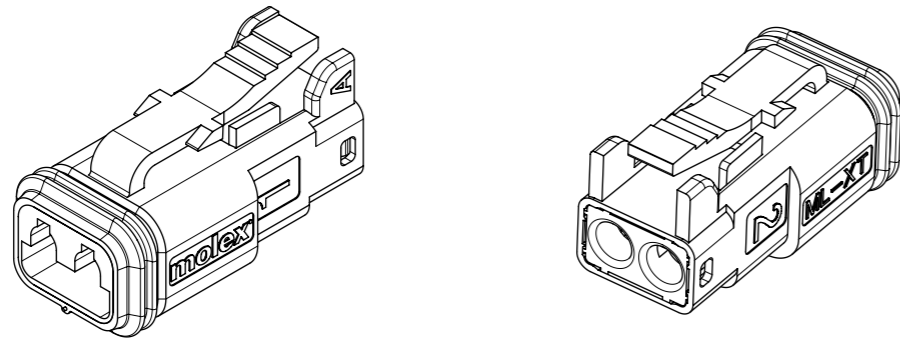

DATE CODE: X XX XX
 X — DAY: 1 - 7
 X — WEEK: 01 - 52
 X — YEAR: 00 - 99
 X —
 EXAMPLE: 11315 = DAY 1, WEEK 13, YEAR 15
 i.e. 23RD OF MARCH 2015

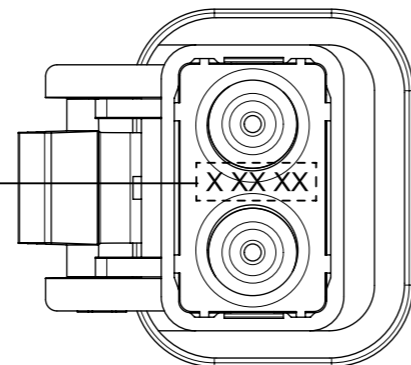

(ROTATED 90°)
 DETAIL B
 SCALE 3:1

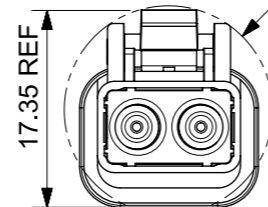
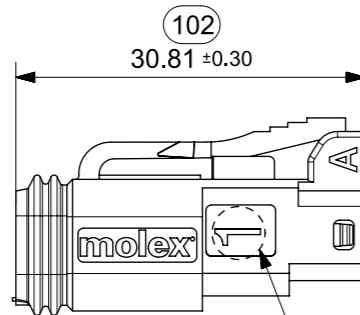
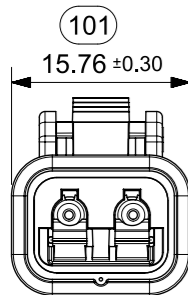

NOTE 2

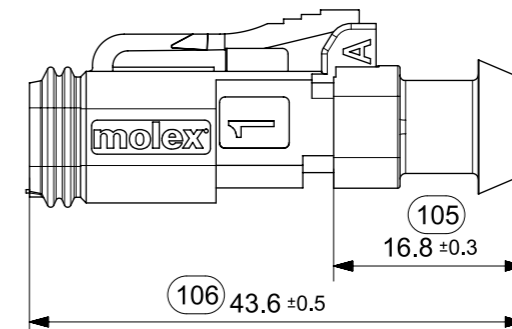
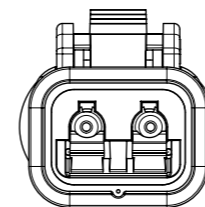
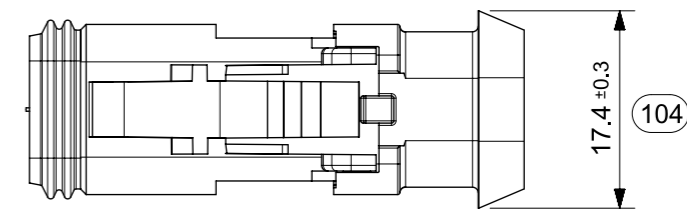

- NOTES
- MATERIAL
 HOUSING: NYLON 30%GF
 PLUG SEAL: SILICONE RUBBER
 BACK SEAL: HIGH CONSISTENCY RUBBER
 - CIRCUIT IDENTIFICATION
 - JACKET RANGE LARGE = 2.7mm TO 3.6mm (SEAL COLOUR: LIGHT BLUE)
 JACKET RANGE SMALL = 1.4mm TO 2.7mm (SEAL COLOUR: BURNT ORANGE)
 - SEE SHEET 6 FOR FINAL PART NUMBER DESIGNATION
 - INSPECTION NUMBERS 101-150 RESERVED FOR SHEET 6
 LAST INSPECTION NUMBER 106.
 INSPECTION NUMBERS 103 & 107 DELETED.

THIS DRAWING CONTAINS INFORMATION THAT IS PROPRIETARY TO MOLEX INCORPORATED AND SHOULD NOT BE USED WITHOUT WRITTEN PERMISSION

SUPERSEDING SD-93443-0010 EC NO: 100661 DRWN: KREILLY CHK'D: FDUGGAN APPR: JDWALLACE	2015/06/12 2015/09/13 2015/09/15	QUALITY SYMBOLS ▽ = 0 ▽ = 0 ▽ = 0 ▼ = 0 ▽ = 0 ☒ = 0 ■ = 0 ▽ = 0	GENERAL TOLERANCES (UNLESS SPECIFIED) ANGULAR TOL ± 2.0 ° 4 PLACES ± 3 PLACES ± 2 PLACES ± 0.1 1 PLACE ± 0.2 0 PLACES ± DRAFT WHERE APPLICABLE MUST REMAIN WITHIN DIMENSIONS	DIMENSION UNITS MM SCALE 1.5:1	DRWN BY KREILLY DATE 2015/06/12		2CCT ML-XT CV CONNECTOR		
	CHK'D BY FDUGGAN DATE 2015/09/13	APPR BY JDWALLACE DATE 2015/09/15	SERIES 93443	MATERIAL NUMBER SEE SHEET 6	CUSTOMER				
	A	REV 3	DRAWING SIZE A3	THIRD ANGLE PROJECTION	DOCUMENT NUMBER 934430010	DOC TYPE PSD	DOC PART 000	SHEET NUMBER 6 OF 9	PRODUCT CUSTOMER DRAWING

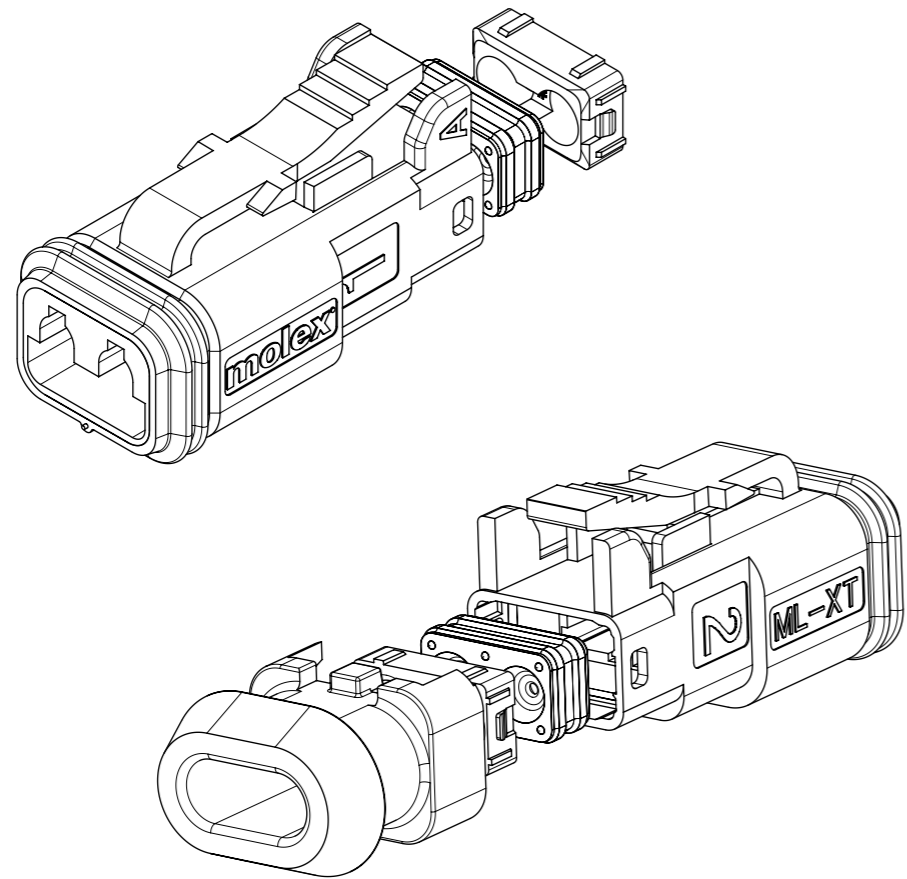

2CCT PLUG CONNECTOR

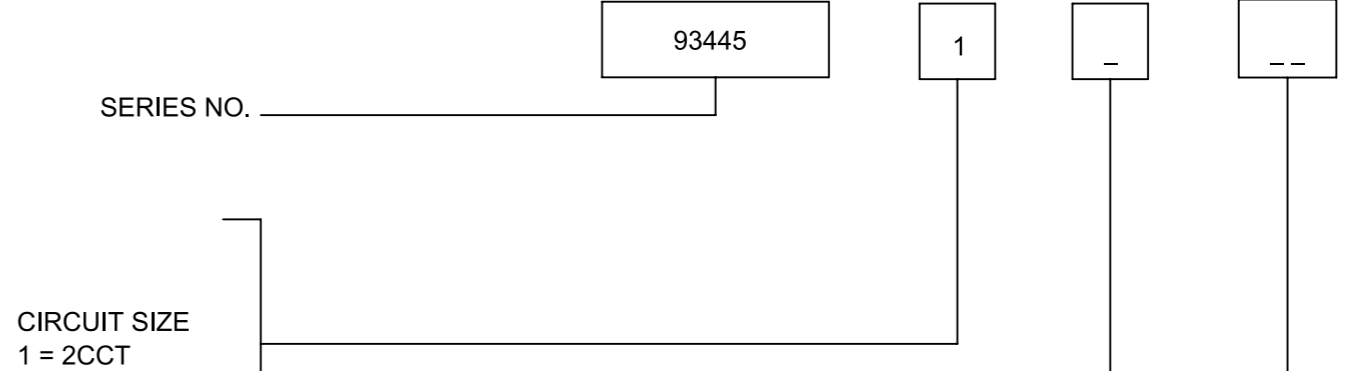

KEYING/ASSY OPTIONS

- 1 = PLUG ASSEMBLY FOR WIRE JACKET RANGE \varnothing 1.4mm-2.7mm (NOTE 2)
- 2 = PLUG ASSEMBLY FOR WIRE JACKET RANGE: \varnothing 2.7mm-3.6mm (NOTE 2)
- 5 = PLUG ASSEMBLY & HEATSHR FOR WIRE JACKET RANGE: \varnothing 1.4mm-2.7mm (NOTE 3)
- 6 = PLUG ASSEMBLY & HEATSHR FOR WIRE JACKET RANGE: \varnothing 2.7mm-3.6mm (NOTE 3)

COLOUR

- 01 = BLACK
- 02 = GREY 06 = WHITE
- 03 = GREEN 07 = BROWN
- 04 = BLUE 08 = ORANGE
- 05 = YELLOW 09 = RED

EXAMPLE:

2CCT PLUG BLACK WITH LARGE SEAL (NOTE 4), AND HEATSHRINK = 93445-1601

Notes:

1. SEE SHEET 2 FOR UNSPECIFIED NOTES AND DIMENSIONS
2. BACK COVER HOUSING COLOUR: BLACK
3. HEATSHRINK HOUSING COLOUR: BLACK
4. JACKET RANGE LARGE = 2.7mm TO 3.6mm (SEAL COLOUR: LIGHT BLUE)
JACKET RANGE SMALL = 1.4mm TO 2.7mm (SEAL COLOUR: BURNT ORANGE)

THIS DRAWING CONTAINS INFORMATION THAT IS PROPRIETARY TO MOLEX INCORPORATED AND SHOULD NOT BE USED WITHOUT WRITTEN PERMISSION

SUPERSEDING SD-93443-0010 EC NO: 100661 DRWN: KREILLY CHK'D: FDUGGAN APPR: JDWALLACE	2015/06/12 2015/09/13 2015/09/15	QUALITY SYMBOLS ▽ = 0 ▽ = 0 ▽ = 0 ▼ = 0 ▽ = 0 ☒ = 0 ■ = 0 ▽ = 0	GENERAL TOLERANCES (UNLESS SPECIFIED) ANGULAR TOL ± 2.0 ° 4 PLACES ± 3 PLACES ± 2 PLACES ± 0.1 1 PLACE ± 0.2 0 PLACES ± DRAFT WHERE APPLICABLE MUST REMAIN WITHIN DIMENSIONS	DIMENSION UNITS MM	SCALE 2:1			
	DRWN BY KREILLY			DATE 2015/06/12	2CCT ML-XT CV CONNECTOR			
	CHK'D BY FDUGGAN			DATE 2015/09/13				PRODUCT CUSTOMER DRAWING
	APPR BY JDWALLACE			DATE 2015/09/15	SERIES 93443	MATERIAL NUMBER SEE CHART	CUSTOMER	
A	REV	DRAWING SIZE A3	THIRD ANGLE PROJECTION 	DOCUMENT NUMBER 934430010	DOC TYPE PSD	DOC PART 000	SHEET NUMBER 7 OF 9	

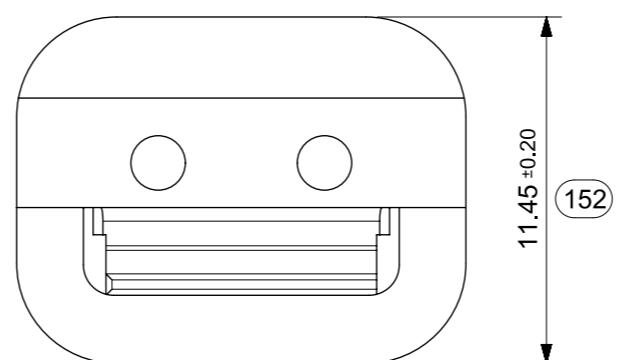
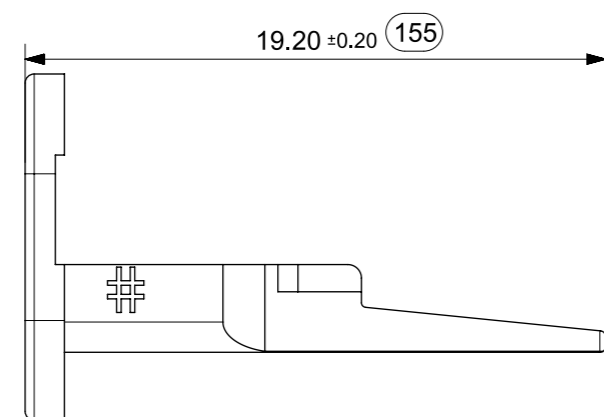
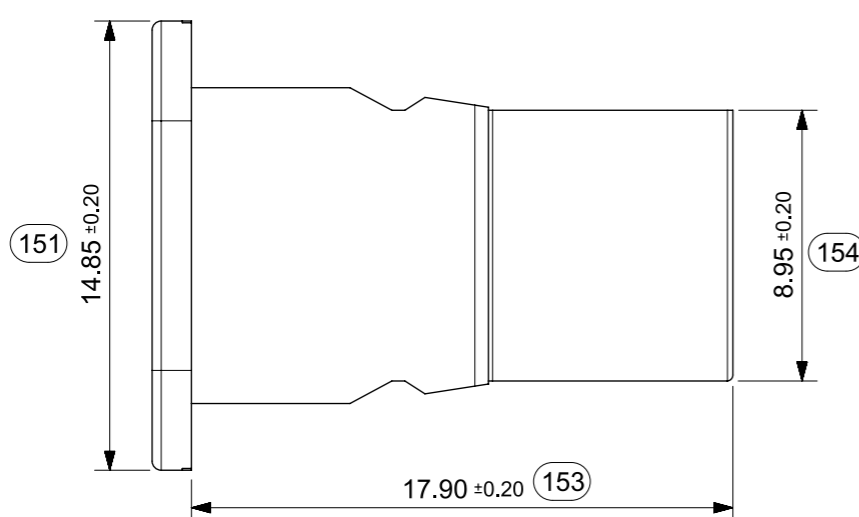
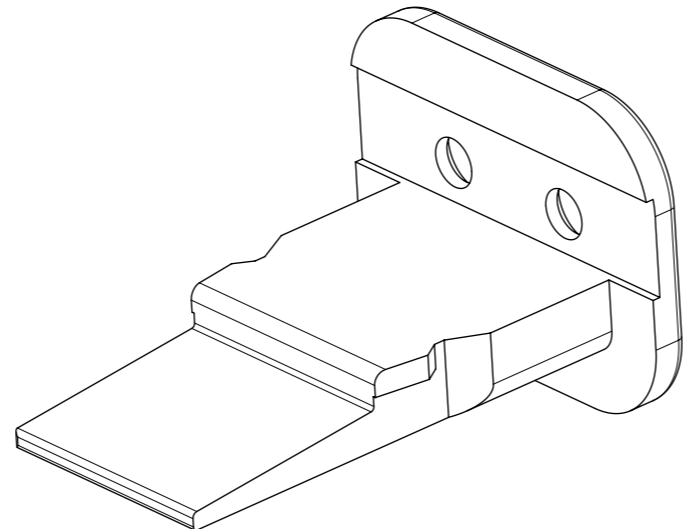
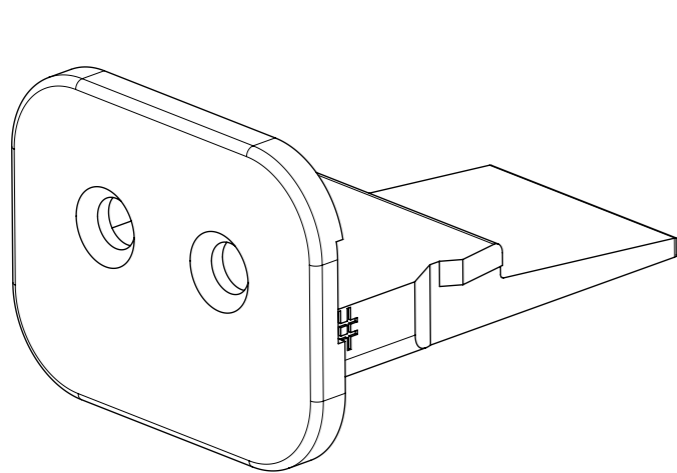

2CCT PLUG WEDGELOCK

SERIES NO. 93448 1 0 --

CIRCUIT SIZE
1 = 2CCT

COLOUR/KEYING
03 = GREEN (NO KEY)
12 = GREY A KEY
21 = BLACK B KEY
33 = GREEN C KEY
47 = BROWN D KEY

NOTES
 1. MATERIAL
 HOUSING: NYLON 30%GF
 2. INSPECTION NUMBERS 151-200 RESERVED FOR SHEET 8
 3. PART NUMBER 934481003 SHOWN
 LAST INSPECTION NUMBER 155

THIS DRAWING CONTAINS INFORMATION THAT IS PROPRIETARY TO MOLEX INCORPORATED AND SHOULD NOT BE USED WITHOUT WRITTEN PERMISSION											
SUPERSEDING SD-93443-0010 EC NO: 100661 DRWN: KREILLY CHK'D: FDUGGAN APPR: JDWALLACE	2015/06/12 2015/09/13 2015/09/15	QUALITY SYMBOLS ▽ = 0 ▽ = 0 ▽ = 0 ▼ = 0 ▽ = 0 ☒ = 0 ■ = 0 ▽ = 0	GENERAL TOLERANCES (UNLESS SPECIFIED)		DIMENSION UNITS MM	SCALE 4:1					
			ANGULAR TOL ± 2.0 °		DRWN BY KREILLY	DATE 2015/06/12					
			4 PLACES ±		CHK'D BY FDUGGAN	DATE 2015/09/13	2CCT ML-XT CV CONNECTOR				
			3 PLACES ±		APPR BY JDWALLACE	DATE 2015/09/15					
2 PLACES ± 0.1		DRAWING SIZE A3		THIRD ANGLE PROJECTION		PRODUCT CUSTOMER DRAWING					
1 PLACE ± 0.2		DRAFT WHERE APPLICABLE MUST REMAIN WITHIN DIMENSIONS				SERIES 93443	MATERIAL NUMBER SEE CHART	CUSTOMER			
0 PLACES ±						DOCUMENT NUMBER 934430010	DOC TYPE PSD	DOC PART 000	SHEET NUMBER 8 OF 9		

934481012 (KEY A)
COLOUR GREY

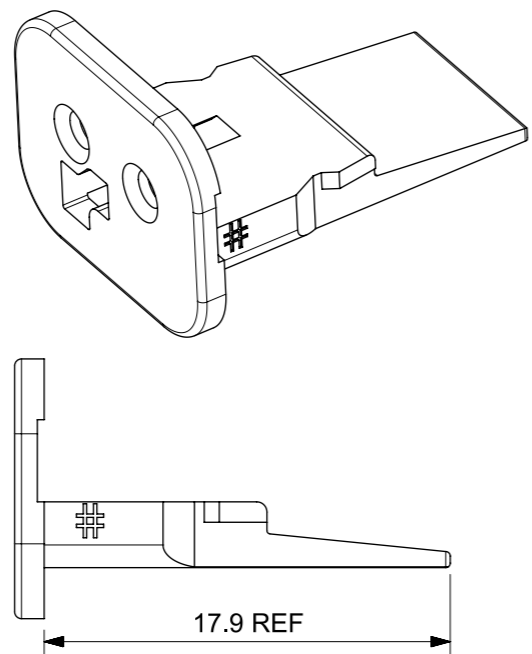
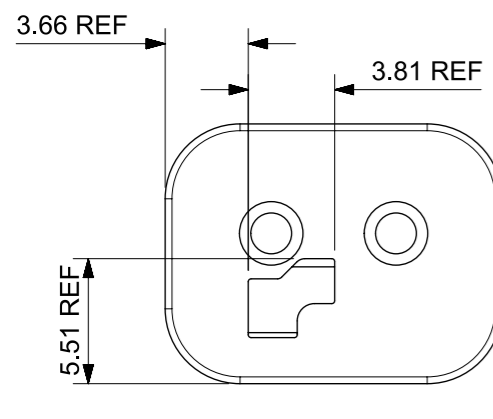

934481021 (KEY B)
COLOUR BLACK

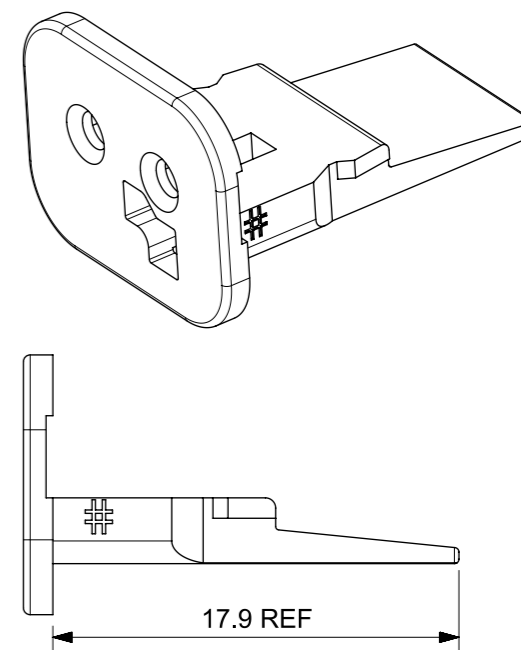
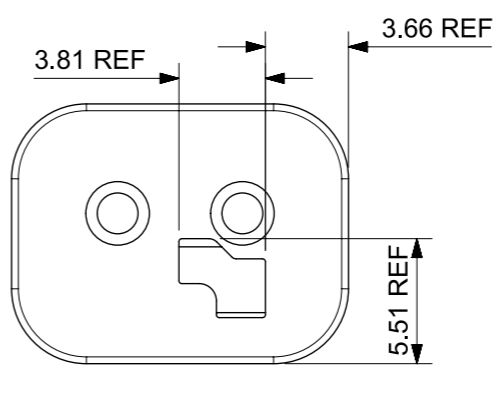

934481033 (KEY C)
COLOUR GREEN

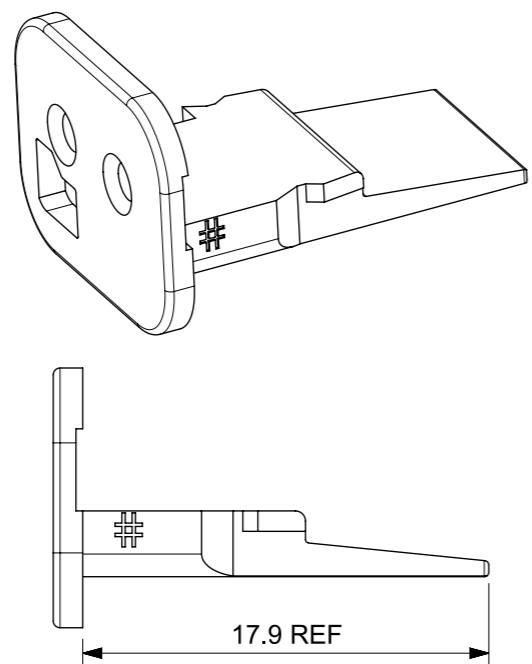
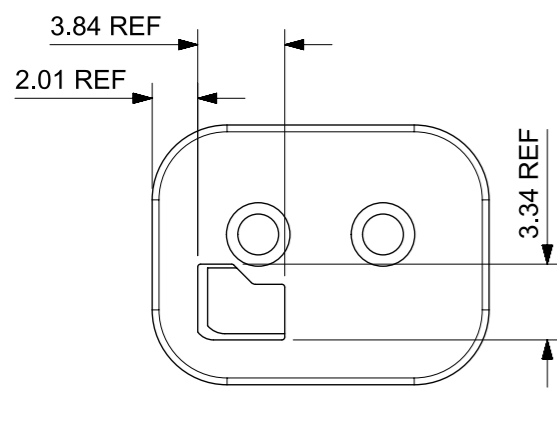

934481047 (KEY D)
COLOUR BROWN

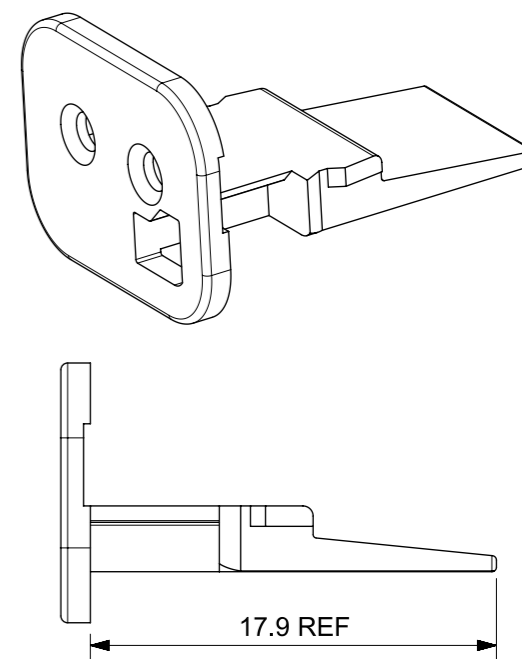
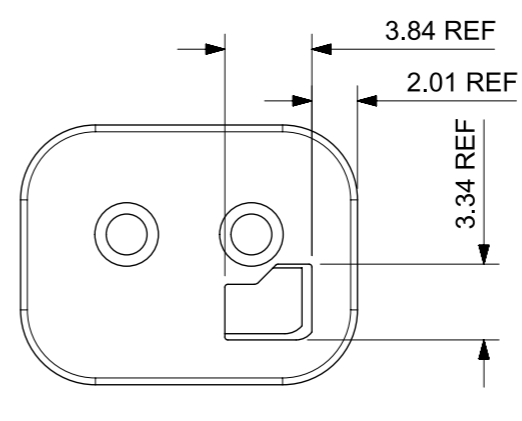

NOTES:
1. MATERIAL PA66 30%GF
2. SEE SHEET 8 FOR UNSPECIFIED NOTES & DIMENSIONS

THIS DRAWING CONTAINS INFORMATION THAT IS PROPRIETARY TO MOLEX INCORPORATED AND SHOULD NOT BE USED WITHOUT WRITTEN PERMISSION

SUPERSEDING SD-93443-0010 EC NO: 100661 DRWN: KREILLY CHK'D: FDUGGAN APPR: JDWALLACE	2015/06/12	2015/09/13	2015/09/15	QUALITY SYMBOLS ∇ = 0 ∇ = 0 ∇ = 0 ▼ = 0 ∇ = 0 ☒ = 0 ■ = 0 ▽ = 0	GENERAL TOLERANCES (UNLESS SPECIFIED) ANGULAR TOL ± 2.0 ° 4 PLACES ± 3 PLACES ± 2 PLACES ± 0.1 1 PLACE ± 0.2 0 PLACES ± DRAFT WHERE APPLICABLE MUST REMAIN WITHIN DIMENSIONS	DIMENSION UNITS MM		SCALE 3:1	2CCT ML-XT CV CONNECTOR			
	DRWN BY	DATE				KREILLY 2015/06/12						
	CHK'D BY	DATE				FDUGGAN 2015/09/13						
	APPR BY	DATE				JDWALLACE 2015/09/15						
A	REV	DRAWING SIZE A3		THIRD ANGLE PROJECTION		SERIES 93443		MATERIAL NUMBER 934430010		CUSTOMER		
		DOCUMENT NUMBER 934430010		DOC TYPE PSD	DOC PART 000	SHEET NUMBER 9 OF 9						