

【1. 適用範囲 SCOPE】

本仕様書は、_____ 殿 に納入する
_____ 1.0mm PITCH 電線対基板 コネクタ 2列ライトアングル _____ について規定する。
This specification covers the 1.0 mm PITCH WIRE TO BOARD CONNECTOR 2-ROW RIGHT ANGLE series.

【2. 製品名称及び型番 PRODUCT NAME AND PART NUMBER】

製品名称 Product Name	製品型番 Part Number
ターミナル Terminal	501193-2*00 501193-3*00
リセハウジング Rec Housing	501189-**10
ウエハーアセンブリ Wafer Assembly	501571-**09
501571-**09 エンボス梱包品 Embossed Tape Packaging For 501571-**09	501571-**07

* : 図面参照 Refer to the drawing.

【3. 定格及び適用電線 RATINGS AND APPLICABLE WIRES】

項目 Item	規格 Standard	
最大許容電圧 Rated Voltage (MAX.)	50 V	
最大許容電流 Rated Current (MAX.)	AWG#28	1.0A
	AWG#30	1.0A
	AWG#32	0.8A
使用温度範囲 Ambient Temperature Range (Operating and Non-operating)	-40°C ~ +85°C*1 低温において氷結しないこと Not freeze to low temperature	

*1 : 通電による温度上昇分も含む。
Including terminal temperature rise.

REV.	D	E	E	G										
SHEET	1~10	1~10	1~10	1~11										
REVISE ON PC ONLY					TITLE: 1.0 WIRE TO BOARD CONNECTOR (2-ROW RIGHT ANGLE) 製品仕様書									
G	変更 REVISED ECN No. J2013-0616 '12/12/19 N. ITO				THIS DOCUMENT CONTAINS INFORMATION THAT IS PROPRIETARY TO MOLEX INC. AND SHOULD NOT BE USED WITHOUT WRITTEN PERMISSION									
REV.	DESCRIPTION				WRITTEN BY: TR.SUZUKI	CHECKED BY: M.YAGI	APPROVED BY: A.NODA	DATE : YR/MO/DAY 2005/02/23						
DESIGN CONTROL J					STATUS									

DOCUMENT NUMBER PS-501571-001	FILE NAME PS501571001.doc	SHEET 1 of 11
---	------------------------------	------------------

【4. 性能 PERFORMANCE】

4-1. 電氣的性能 Electrical performance

項 目 Item		条 件 Test Condition	規 格 Requirement
4-1-1	接 触 抵 抗 Contact Resistance	コネクタを嵌合させ、開放電圧 20mV以下、短絡電流 10mA にて測定する。 (JIS C5402 5.4) Mate connectors and measured by dry circuit, 20mV MAX., 10mA. (JIS C5402 5.4)	20 milliohms MAX.
4-1-2	絶 縁 抵 抗 Insulation Resistance	コネクタを嵌合させ、隣接するターミナル間及びターミナル、アース間に、DC 500Vを印加し測定する。 (JIS C5402 5.2/MIL-STD-202 試験法 302) Mate connectors and apply 500V DC between adjacent terminal or ground. (JIS C5402 5.2/MIL-STD-202 Method 302)	100 Megohms MIN.
4-1-3	耐 電 圧 Dielectric Strength	コネクタを嵌合させ、隣接するターミナル間及びターミナル、アース間に、AC(rms) 250V (実効値) を1分間 印加する。 (JIS C5402 5.1/MIL-STD-202 試験法 301) Mate connectors and apply 250V AC(rms) for 1 minute between adjacent terminal or ground. (JIS C5402 5.1/MIL-STD-202 Method 301)	異状なきこと No Breakdown
4-1-4	圧着部接触抵抗 Contact Resistance on Crimped Portion	ターミナルに適合電線を圧着し、開放電圧20mV以下、短絡電流 10mA にて測定する。 Crimp the applicable wire to the terminal, measured by dry circuit, 20mV MAX., 10mA.	5 milliohms MAX.

REVISE ON PC ONLY

G

SEE SHEET 1 of 11

TITLE:

1.0 WIRE TO BOARD CONN.
(2-ROW RIGHT ANGLE)

製品仕様書

THIS DOCUMENT CONTAINS INFORMATION THAT IS PROPRIETARY TO MOLEX INC. AND SHOULD NOT BE USED WITHOUT WRITTEN PERMISSION

REV.

DESCRIPTION

DOCUMENT NUMBER

PS-501571-001

FILE NAME

PS501571001.doc

SHEET

2 of 11

4-2. 機械的性能 Mechanical Performance

項目 Item		条件 Test Condition		規格 Requirement
4-2-1	挿入力及び抜去力 Insertion and Withdrawal Force	毎分 25±3mm の速さで挿入、抜去を行う。 Insert and withdraw connectors at the speed rate of 25±3 mm/minute.		第 6 項参照 Refer to paragraph 6
4-2-2	圧着部引張強度 Crimping Pull out Force	圧着されたターミナルを治具に固定し、電線を軸方向に毎分25±3mmの速さで引張る。 (JIS C5402 6.8) Fix the crimped terminal, apply axial pull out force on the wire at the speed rate of 25±3mm/minute. (JIS C5402 6.8)	AWG#28	9.8N{1.0kgf}MIN.
			AWG#30	4.9N{0.5kgf}MIN.
			AWG#32	3.0N{0.3kgf}MIN.
4-2-3	ターミナル挿入力 Terminal Insertion Force	圧着されたターミナルをハウジングに挿入する。 Insert the crimped terminal into the housing.		4.9N {0.5 kgf} MAX.
4-2-4	ターミナル保持力 Terminal / Housing Retention Force	ハウジングに装着されたターミナルを毎分 25±3mm の速さで引張る。 Apply axial pull out force at the speed rate of 25±3mm/minute on the terminal assembled in the housing.		4.9N {0.5 kgf} MIN.
4-2-5	ピン保持力 Pin Retention Force	<上段列ピン Upper row pin> ウエハーに装着されたピンを毎分 25±3mm の速さで軸方向に押す。 Apply axial push force at the speed rate of 25±3mm/minute on the pin assembled in the wafer.		2.94N {0.3 kgf} MIN.
		<下段列ピン Bottom row pin> ウエハーに装着されたピンを毎分 25±3mm の速さで軸方向に引張る。 Apply axial pull out force at the speed rate of 25±3mm/minute on the pin assembled in the wafer.		
4-2-6	ハウジングロック 強度 Housing Lock Strength	ハウジングを嵌合し、軸方向に毎分25±3mmの速さで引張る。 Mated connectors ,and apply axial pull out force at the speed rate of 25±3mm/minute.		19.6N{2 kgf} MIN.

REVISE ON PC ONLY		TITLE:	
G	SEE SHEET 1 of 11	1.0 WIRE TO BOARD CONN. (2-ROW RIGHT ANGLE) 製品仕様書	
		THIS DOCUMENT CONTAINS INFORMATION THAT IS PROPRIETARY TO MOLEX INC. AND SHOULD NOT BE USED WITHOUT WRITTEN PERMISSION	
REV.	DESCRIPTION	FILE NAME	SHEET
DOCUMENT NUMBER PS-501571-001		PS501571001.doc	3 of 11

4-3. その他 Environmental Performance and Others

項目 Item		条件 Test Condition	規格 Requirement	
4-3-1	挿抜寿命 Repeated Insertion / Withdrawal	1分間 10回 以下の速さで挿入、抜去を30回 繰返す。 When mated up to 30 cycles repeatedly by the rate of 10 cycles per minute.	接触抵抗 Contact Resistance	40 milliohms MAX.
4-3-2	温度上昇 Temperature Rise	コネクタを嵌合させ、最大許容電流を通电し、コネクタの温度上昇分を測定する。(UL 498) Carrying rated current load. (UL 498)	温度上昇 Temperature Rise	30 °C MAX.
4-3-3	耐振動性 Vibration	DC 1mA 通电状態にて、嵌合軸を含む互いに垂直な 3方向に 掃引割合 10~55~10 Hz/分、全振幅 1.52mm の振動を各2時間 加える。 (MIL-STD-202 試験法 201) Amplitude : 1.52mm P-P Frequency : 10~55~10 Hz in 1 minute. Duration : 2 hours in each X.Y.Z.axes. (MIL-STD-202 Method 201)	外観 Appearance	異常なきこと No Damage
			接触抵抗 Contact Resistance	40 milliohms MAX.
			瞬断 Discontinuity	1 microsecond MAX.
4-3-4	耐衝撃性 Mechanical Shock	DC 1mA 通电状態にて、嵌合軸を含む互いに垂直な 6方向に 490m/s ² { 50G } の衝撃を各3回 加える。 (JIS C60068-2-27/MIL-STD-202 試験法 213) 490m/s ² { 50G } , 3 strokes in each X.Y.Z. axes. (JIS C60068-2-27/MIL-STD-202 Method 213)	外観 Appearance	異常なきこと No Damage
			接触抵抗 Contact Resistance	40 milliohms MAX.
			瞬断 Discontinuity	1 microsecond MAX.
4-3-5	耐熱性 Heat Resistance	コネクタを嵌合させ、85±2°C の雰囲気中に96時間放置後取り出し、1時間 室温に放置する。 (JIS C60068-2-2/MIL-STD-202 試験法 108) 85±2°C, 96 hours (JIS C60068-2-2/MIL-STD-202 Method 108)	外観 Appearance	異常なきこと No Damage
			接触抵抗 Contact Resistance	40 milliohms MAX

REVISE ON PC ONLY		TITLE: 1.0 WIRE TO BOARD CONN. (2-ROW RIGHT ANGLE) 製品仕様書
G	SEE SHEET 1 of 11	
REV.	DESCRIPTION	THIS DOCUMENT CONTAINS INFORMATION THAT IS PROPRIETARY TO MOLEX INC. AND SHOULD NOT BE USED WITHOUT WRITTEN PERMISSION

DOCUMENT NUMBER PS-501571-001	FILE NAME PS501571001.doc	SHEET 4 of 11
---	------------------------------	------------------

項 目 Item		条 件 Test Condition	規 格 Requirement	
4-3-6	耐寒性 Cold Resistance	コネクタを嵌合させ、 $-40\pm 3^{\circ}\text{C}$ の雰囲気中に96時間 放置後取り出し、1時間 室温に放置する。 (JIS C60068-2-1) $-40\pm 3^{\circ}\text{C}$, 96 hours (JIS C60068-2-1)	外 観 Appearance	異常なきこと No Damage
			接 触 抵 抗 Contact Resistance	40 milliohms MAX.
4-3-7	耐湿性 Humidity	コネクタを嵌合させ、 $60\pm 2^{\circ}\text{C}$ 、相対湿度 90~95% の雰囲気中に 96時間 放置後 取り出し、1時間 室温に放置する。 (JIS C60068-2-3/MIL-STD-202 試験法 103) Temperature : $60\pm 2^{\circ}\text{C}$ Relative Humidity : 90~95% Duration : 96 hours (JIS C60068-2-3/MIL-STD-202 Method 103)	外 観 Appearance	異常なきこと No Damage
			接 触 抵 抗 Contact Resistance	40 milliohms MAX.
			耐電圧 Dielectric Strength	4-1-3項満足のこと Must meet 4-1-3
			絶縁抵抗 Insulation Resistance	10 Megohms MIN.
4-3-8	温度サイクル Temperature Cycling	コネクタを嵌合させ、 -55°C に 30分、 $+105^{\circ}\text{C}$ に30分これを1サイクルとし、5サイクル 繰返す。但し、温度移行時間は5分以内 とする。試験後1~2時間 室温に放置する。 (JIS C0025) 5 cycles of : a) -55°C 30 minutes b) $+105^{\circ}\text{C}$ 30 minutes (JIS C0025)	外 観 Appearance	異常なきこと No Damage
			接 触 抵 抗 Contact Resistance	40 milliohms MAX.
4-3-10	塩水噴霧 Salt Spray	コネクタを嵌合させ、 $35\pm 2^{\circ}\text{C}$ にて $5\pm 1\%$ 重量比 の塩水を 48 ± 4 時間 噴霧し、試験後 常温で水洗いした後、室温で乾燥させる。 (JIS C60068-2-11/MIL-STD-202 試験法101) 48 ± 4 hours exposure to a salt spray from the $5\pm 1\%$ solution at $35\pm 2^{\circ}\text{C}$. (JIS C60068-2-11/MIL-STD-202 Method 101)	外 観 Appearance	異常なきこと No Damage
			接 触 抵 抗 Contact Resistance	40 milliohms MAX.
4-3-11	亜硫酸ガス SO ₂ Gas	コネクタを嵌合させ、 $40\pm 2^{\circ}\text{C}$ にて 50 ± 5 ppm の亜硫酸ガス中に 24時間 放置する。 24 hours exposure to 50 ± 5 ppm SO ₂ gas at $40\pm 2^{\circ}\text{C}$.	外 観 Appearance	異常なきこと No Damage
			接 触 抵 抗 Contact Resistance	40 milliohms MAX.

REVISE ON PC ONLY		TITLE: 1.0 WIRE TO BOARD CONN. (2-ROW RIGHT ANGLE) 製品仕様書
G	SEE SHEET 1 of 11	
REV.	DESCRIPTION	THIS DOCUMENT CONTAINS INFORMATION THAT IS PROPRIETARY TO MOLEX INC. AND SHOULD NOT BE USED WITHOUT WRITTEN PERMISSION

DOCUMENT NUMBER PS-501571-001	FILE NAME PS501571001.doc	SHEET 5 of 11
---	------------------------------	------------------

項 目 Item		条 件 Test Condition	規 格 Requirement	
4-3-12	耐アンモニア性 NH ₃ Gas	コネクタを嵌合させ、濃度28%のアンモニア水を入れた容器中に40分間放置する。 (1Lに対して25mLの割合) 40 minutes exposure to NH ₃ gas evaporating from 28% Ammonia solution.	外 観 Appearance	異状なきこと No Damage
			接 触 抵 抗 Contact Resistance	40 milliohms MAX.
4-3-13	半田付け性 Solder ability	端子先端及び金具先端より0.5mm迄、245±3℃の半田に3±0.5秒浸す。 Soldering Time: 3±0.5seconds Solder Temperature: 245±3℃ 0.5mm from terminal tip and fitting nail tip.	濡れ性 Solder Wetting	浸漬面積の90%以上 90% of immersed area must show no voids, pin holes.
4-3-14	半田耐熱性 Resistance to Soldering Heat	リフロー時 第7項の条件にて行う。 <u>Refer soldering method</u> See paragraph 7.	外 観 Appearance	端子ガタ、割れ等 異状なきこと No Damage
		手半田時 端子先端及び金具先端より0.2mmの位置まで、370~400℃の半田ゴテにて3±1秒以下加熱する。 <u>Soldering iron method</u> 0.2mm from terminal tip Solder Temperature : 370~400℃ Soldering Time : 3±1 seconds MAX.		

() : 参考規格 Reference Standard
{ } : 参考単位 Reference Unit

【5. 外観形状、寸法及び材質 PRODUCT SHAPE, DIMENSIONS AND MATERIALS】

図面参照 Refer to the drawing.

REVISE ON PC ONLY	TITLE: 1.0 WIRE TO BOARD CONN. (2-ROW RIGHT ANGLE) 製品仕様書	THIS DOCUMENT CONTAINS INFORMATION THAT IS PROPRIETARY TO MOLEX INC. AND SHOULD NOT BE USED WITHOUT WRITTEN PERMISSION	
			SEE SHEET 1 of 11
REV.	DESCRIPTION		
DOCUMENT NUMBER PS-501571-001		FILE NAME PS501571001.doc	SHEET 6 of 11

【6. 挿入力及び抜去力 INSERTION / WITHDRAWAL FORCE】

極数 No. of CKT	単位 UNIT	挿入力 (最大値) Insertion (MAX.)			抜去力 (最小値) Withdrawal (MIN.)		
		初回 1st	6回目 6th	30回目 30th	初回 1st	6回目 6th	30回目 30th
20	N {kgf}	29.4 {3.0}	29.4 {3.0}	29.4 {3.0}	3.4 {0.35}	3.4 {0.35}	3.4 {0.35}
30	N {kgf}	44.1 {4.5}	44.1 {4.5}	44.1 {4.5}	4.9 {0.5}	4.9 {0.5}	4.9 {0.5}
40	N {kgf}	58.8 {6.0}	58.8 {6.0}	58.8 {6.0}	5.9 {0.6}	5.9 {0.6}	5.9 {0.6}
50	N {kgf}	73.5 {7.5}	73.5 {7.5}	73.5 {7.5}	7.8 {0.8}	7.8 {0.8}	7.8 {0.8}

※ロックを解除して測定 Released lock, and measure.

{ } :参考単位 Reference Unit

G	REVISE ON PC ONLY	TITLE: 1.0 WIRE TO BOARD CONN. (2-ROW RIGHT ANGLE) 製品仕様書
	SEE SHEET 1 of 11	
REV.	DESCRIPTION	THIS DOCUMENT CONTAINS INFORMATION THAT IS PROPRIETARY TO MOLEX INC. AND SHOULD NOT BE USED WITHOUT WRITTEN PERMISSION
DOCUMENT NUMBER PS-501571-001		FILE NAME PS501571001.doc
		SHEET 7 of 11

【 7. 赤外線リフロー条件 INFRARED REFLOW CONDITION 】

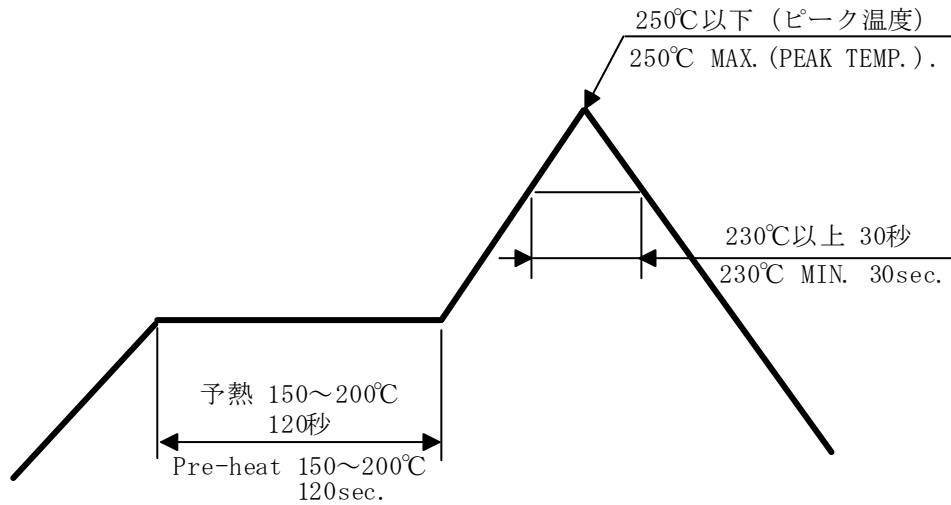

温度条件グラフ
TEMPERATURE CONDITION GRAPH
(基板表面温度)
(TEMPERATURE ON BOARD PATTERN SIDE)

注記：本リフロー条件に関しては、リフロー装置及び基板などにより条件が異なりますので
 事前に実装評価(リフロー評価)の御確認を御願ひ致します。
 フィッティングネイルが変色する場合がございますが、半田付け性には問題ありません。
 NOTE : Please check the mount condition (reflow soldering condition) by your own devices
 beforehand, because the condition changes by the soldering devices, p.c. boards, and so on.
 Although fitting nail may discolors, a solderability does not have a problem

G	REVISE ON PC ONLY	TITLE: 1.0 WIRE TO BOARD CONN. (2-ROW RIGHT ANGLE) 製品仕様書
	SEE SHEET 1 of 11	
REV.	DESCRIPTION	THIS DOCUMENT CONTAINS INFORMATION THAT IS PROPRIETARY TO MOLEX INC. AND SHOULD NOT BE USED WITHOUT WRITTEN PERMISSION
DOCUMENT NUMBER PS-501571-001		FILE NAME PS501571001.doc
		SHEET 8 of 11

【8. 取り扱い上の注意事項 INSTRUCTION UPON USAGE】

- 1.コネクタの嵌合を取り外す際は、必ずロックを解除して行って下さい。
When unmated connectors, positive locks shall be released.
- 2.嵌合時にリセハウジングの矢印で示す部位を押し嵌合して下さい。
電線やハウジングのロック部を押した場合、これらが破損する恐れがありますのでお避け下さい。
Please push the part directed by FIG.1 at the time of mate.
It may damage, when electric wires or lock part of the receptacle housing are pushed.



図1
FIG.1

3. 本製品の樹脂部に多少の傷や、めっきの色相が異なる事がありますが、製品性能には影響ございません。
Although this product may have a weld line or a scratch on the housing, and a different color condition of plating, these will not have any influence on the product's performance.
4. 本製品のプラスチック部に黒点、気泡等が確認される場合や色合いが異なる場合（経年変化によるハウジング変色を含む）がありますが、製品性能に影響はありません。
There is no influence in the product performance though the black spot or bubble etc. might be confirmed to the plastic part of this product and the shade might be different (discoloration by secular distortion etc.).
5. 本製品のハウジング及びメッキ表面に多少の傷が確認される場合がありますが、製品性能に問題ありません。
A few scratch may be confirmed to the surface of the housing and the plating of this product, however, There is no problem in the product performance.

G	REVISE ON PC ONLY	TITLE: 1.0 WIRE TO BOARD CONN. (2-ROW RIGHT ANGLE) 製品仕様書
	SEE SHEET 1 of 11	
REV.	DESCRIPTION	THIS DOCUMENT CONTAINS INFORMATION THAT IS PROPRIETARY TO MOLEX INC. AND SHOULD NOT BE USED WITHOUT WRITTEN PERMISSION
DOCUMENT NUMBER PS-501571-001		FILE NAME PS501571001.doc
		SHEET 9 of 11

6. 本製品のプラスチック部に紫外線により変色する場合がありますが、製品性能に問題ありません。

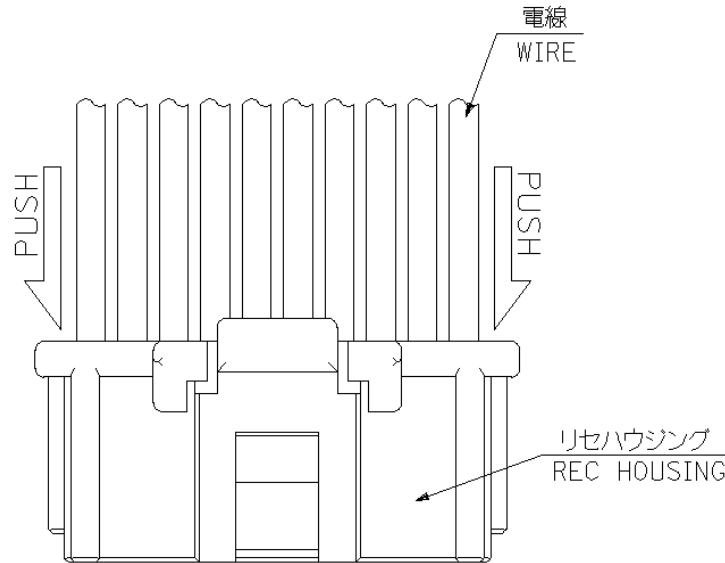
Discoloration of the plastic part of this product can result from exposure to ultraviolet light.
There is no problem in the product performance.

【9. 環境指令への適合 COMPLIANCE WITH ENVIRONMENTAL DIRECTIVE】

1. ELV及びRoHS適合品。

ELV AND RoHS COMPLIANT.

	REVISE ON PC ONLY		TITLE: 1.0 WIRE TO BOARD CONN. (2-ROW RIGHT ANGLE) 製品仕様書
	G	SEE SHEET 1 of 11	
REV.	DESCRIPTION		THIS DOCUMENT CONTAINS INFORMATION THAT IS PROPRIETARY TO MOLEX INC. AND SHOULD NOT BE USED WITHOUT WRITTEN PERMISSION
DOCUMENT NUMBER PS-501571-001			FILE NAME PS501571001.doc
			SHEET 10 of 11

molex PRODUCT SPECIFICATION

LANGUAGE

JAPANESE
ENGLISH

REV.	REV. RECORD	DATE	EC NO.	WRITTEN:	CH'K:
A	新規作成 RELEASED	'05/02/23	J2005-2165	TR.SUZUKI	M.YAGI
B	変更 REVISED	'05/03/30	J2005-2880	TR.SUZUKI	M.YAGI
C	変更 REVISED	'07/09/13	J2008-0716	M.NABEI	T.HARUYAMA
D	変更 REVISED	'09/04/08	J2009-2230	C.ARIZONO	T.HARUYAMA
E	変更 REVISED	'10/09/01	J2010-0328	T.KON	K.ASAKAWA
F	変更 REVISED	'12/08/28	J2013-0245	K.MATSUYAMA	K.ASAKAWA
G	変更 REVISED	'12/12/19	J2013-0616	N.ITO	K.ASAKAWA

G	REVISE ON PC ONLY	TITLE: 1.0 WIRE TO BOARD CONN. (2-ROW RIGHT ANGLE) 製品仕様書
	SEE SHEET 1 of 11	
REV.	DESCRIPTION	THIS DOCUMENT CONTAINS INFORMATION THAT IS PROPRIETARY TO MOLEX INC. AND SHOULD NOT BE USED WITHOUT WRITTEN PERMISSION
DOCUMENT NUMBER PS-501571-001		FILE NAME PS501571001.doc
		SHEET 11 of 11