

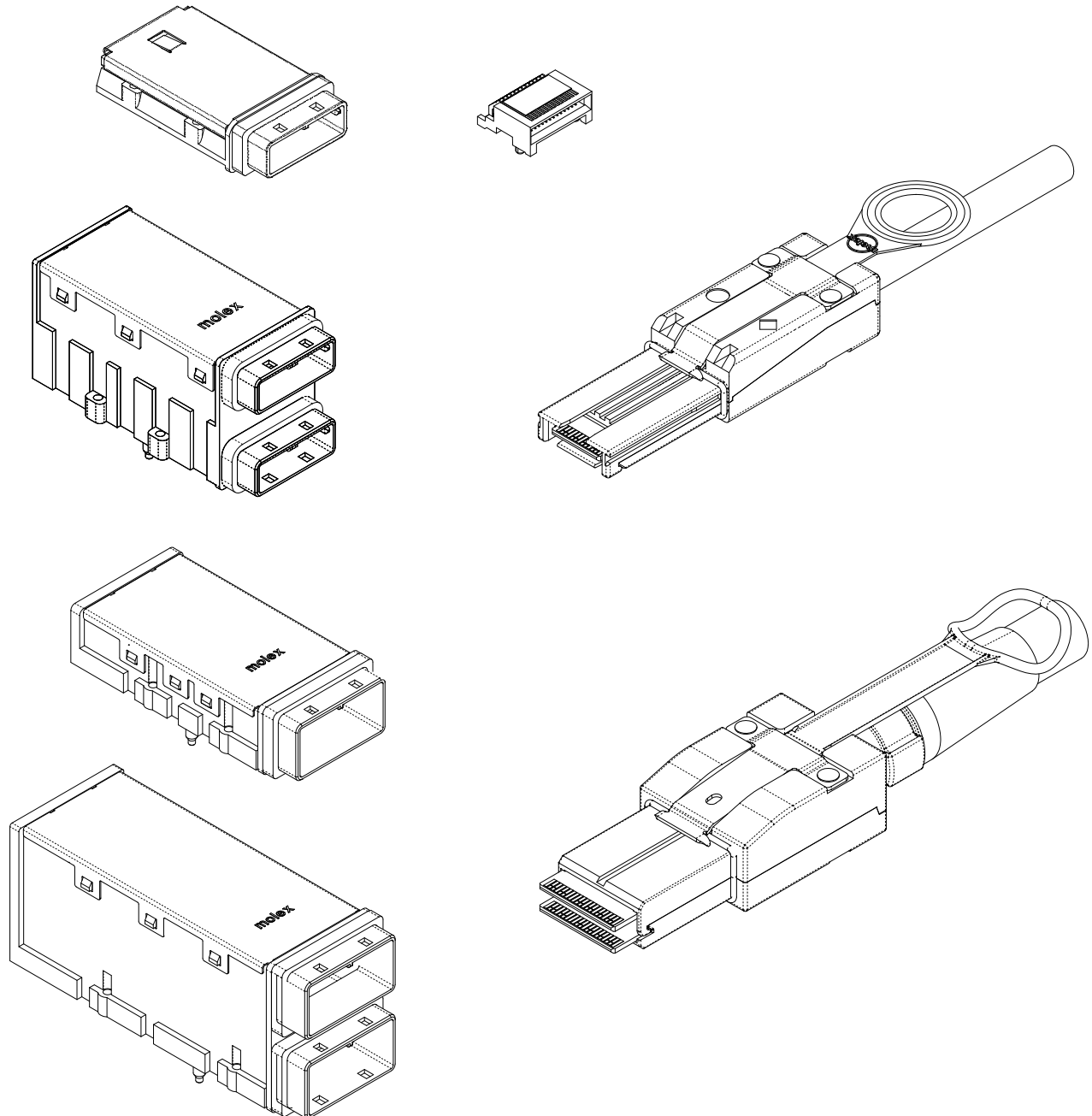

PRODUCT SPECIFICATION

iPASS™ / iPASS+™ 0.8 mm PITCH I/O CONNECTOR SYSTEM



REVISION: D2	ECR/ECN INFORMATION: EC No: UCP2013-0422 DATE: 2012 / 07 / 31	TITLE: PRODUCT SPECIFICATION EXTERNAL iPass™ / iPass+™ I/O CONNECTOR & CABLE	SHEET No. 1 of 21
DOCUMENT NUMBER: PS-75586-001	CREATED / REVISED BY: TMCLELLAND	CHECKED BY: JLONG / JJANTELEZIO	APPROVED BY: MBANAKIS



PRODUCT SPECIFICATION

TABLE OF CONTENTS

1.0	SCOPE	3
2.0	PRODUCT DESCRIPTION	3
2.1	PRODUCT NAME AND SERIES NUMBER(S)	3
2.2	DIMENSION, MATERIALS, PLATING AND MARKINGS	3
2.3	SAFETY AGENCY APPROVALS	3
2.4	PIN ASSIGNMENTS	3
2.5	ADDITIONAL GENERAL SPECIFICATIONS	3
3.0	APPLICABLE DOCUMENTS AND SPECIFICATIONS	4
3.1	MOLEX DOCUMENTS	4
3.2	INDUSTRY DOCUMENTS	4
4.0	QUALIFICATION	4
5.0	RATINGS	4
5.1	VOLTAGE	4
5.2	CURRENT	4
5.3	TEMPERATURE	4
5.4	DURABILITY	4
6.0	PERFORMANCE (MECHANICAL & ENVIRONMENTAL)	5
6.1	TEST GROUP 1	5
6.2	TEST GROUP 2	6
6.3	TEST GROUP 3	7
6.4	TEST GROUP 4	8
	TEST GROUP 4 (CONTINUED)	9
6.5	TEST GROUP 7	10
6.6	MECHANICAL TEST GROUP 1	11
6.7	MECHANICAL TEST GROUP 2	11
6.8	MECHANICAL TEST GROUP 3	12
6.9	MECHANICAL TEST GROUP 4	12
6.10	MECHANICAL TEST GROUP 5	13
6.11	MECHANICAL TEST GROUP 6	13
6.12	MECHANICAL TEST GROUP 7	14
6.13	MECHANICAL TEST GROUP 8	14
7.0	PERFORMANCE (HIGH SPEED CHARACTERIZATION)	15
7.1	SIGNAL INTEGRITY REQUIREMENTS (CONNECTOR ONLY)	15
7.2	SIGNAL INTEGRITY REQUIREMENTS (CONNECTOR & CABLE SYSTEM, SAS/SATA)	16
7.3	SIGNAL INTEGRITY REQUIREMENTS (CONNECTOR & CABLE SYSTEM, PCIE)	17
7.4	SIGNAL INTEGRITY REQUIREMENTS (CONNECTOR & CABLE SYSTEM, 12X)	17
8.0	PACKAGING	18
8.1	CONNECTOR AND SHELL	18
8.2	PLUG AND CABLE ASSEMBLY	18
9.0	GAGES AND FIXTURES	19
10.0	OTHER INFORMATION	20
10.1	MOLEX CONNECTOR ONLY TEST PROFILE	20
10.2	INVERTED SMT APPLICATION	20
10.3	PCB REQUIREMENTS	21

REVISION: D2	ECR/ECN INFORMATION: EC No: UCP2013-0422 DATE: 2012 / 07 / 31	TITLE: PRODUCT SPECIFICATION EXTERNAL iPasstm / iPass+tm I/O CONNECTOR & CABLE	SHEET No. 2 of 21
DOCUMENT NUMBER: PS-75586-001	CREATED / REVISED BY: TMCLELLAND	CHECKED BY: JLONG / JJANTELEZIO	APPROVED BY: MBANAKIS



PRODUCT SPECIFICATION

1.0 SCOPE

This Product Specification covers this 0.8 mm centerline (pitch) printed circuit board (PCB) connector series and cable assemblies.

2.0 PRODUCT DESCRIPTION

2.1 PRODUCT NAME AND SERIES NUMBER(S)

Product Name:	iPass™ Connector Family
Connector Series:	75586
Guide Frame Series:	74540, 74548, 111048, 111049
Guide Frame/Connector Series:	75581, 76024, 76105, 75758
Plug & Cable Series:	74546, 74547, 74588, 74557, 74558, 111048, 111040

2.2 DIMENSION, MATERIALS, PLATING AND MARKINGS

See the appropriate sales drawing for information on dimensions, materials, plating, marking, and footprint patterns.

2.3 SAFETY AGENCY APPROVALS

UL file:	E29179
CSA file:	19980

2.4 PIN ASSIGNMENTS

Pin assignment may vary depending on the cable assembly configuration. Different configurations will have different part numbers within the series. Reference the appropriate cable sales drawing of the specific part number for the correct pin assignment.

2.5 ADDITIONAL GENERAL SPECIFICATIONS

Plug PCB:

- Material is FR4
- Overall thickness of 1mm over pads
- Contacts are 0.76µm minimum hard gold plated over 3.81µm minimum thick nickel plating

Plug:

- Backshells – Zinc Diecast
- Pull – Nylon
- Latch – Stainless Steel

Bulk Cable:

- See specific sales drawing

REVISION: D2	ECR/ECN INFORMATION: EC No: UCP2013-0422 DATE: 2012 / 07 / 31	TITLE: PRODUCT SPECIFICATION EXTERNAL iPass™ / iPass+™ I/O CONNECTOR & CABLE	SHEET No. 3 of 21
DOCUMENT NUMBER: PS-75586-001	CREATED / REVISED BY: TMCLELLAND	CHECKED BY: JLONG / JJANTELEZIO	APPROVED BY: MBANAKIS



PRODUCT SPECIFICATION

3.0 APPLICABLE DOCUMENTS AND SPECIFICATIONS

3.1 MOLEX DOCUMENTS

SD-75586-001	iPass™ Right Angle Connector
AS-75586-001	Application Specification
PK-75586-002	Packaging Specification
PS-45499-002	Cosmetic Specification
SMES-152	Solderability

3.2 INDUSTRY DOCUMENTS

EIA 364 Series	Electrical Connector Test Procedures Including Environmental Classifications with Test Procedures
EIA 364-1000	Environmental Test Methodology for Assessing the Performance of Connectors and Sockets Used in Business Office Applications

4.0 QUALIFICATION

Laboratory condition and sample selection are in accordance with EIA 364

5.0 RATINGS

5.1 VOLTAGE

48 Volts AC (RMS)/DC Max.

5.2 CURRENT

0.75 Amps Max.

5.3 TEMPERATURE

Operating:	-40°C to +80°C
Non-operating:	-55°C to +80°C

5.4 DURABILITY

0.76 µm Au – 250 cycles, 10 year Life (14 day FMG)

REVISION: D2	ECR/ECN INFORMATION: EC No: UCP2013-0422 DATE: 2012 / 07 / 31	TITLE: PRODUCT SPECIFICATION EXTERNAL iPass™ / iPass+™ I/O CONNECTOR & CABLE	SHEET No. 4 of 21
DOCUMENT NUMBER: PS-75586-001	CREATED / REVISED BY: TMCLELLAND	CHECKED BY: JLONG / JJANTELEZIO	APPROVED BY: MBANAKIS



PRODUCT SPECIFICATION

6.0 PERFORMANCE (MECHANICAL & ENVIRONMENTAL)

6.1 TEST GROUP 1

ITEM	TEST	TEST PROCEDURE	CONDITION	REQUIREMENT	ACTUAL
1	Low Level Contact Resistance	EIA-364-23; apply a maximum voltage of 20 mV and a current of 100 mA.	Mated	baseline	PASSED
2	Durability (precondition)	EIA-364-09; perform plug & unplug cycles: 50 times.		No evidence of physical damage	PASSED
3	Temperature Life	EIA-364-17, method A, Test Condition 3 at 105°±2°C for 120 hours	Mated	Conditioning Exposure	PASSED No physical data
4	Low Level Contact Resistance	EIA-364-23; apply a maximum voltage of 20 mV and a current of 100 mA.	Mated	< 10 mΩ Δ max from initial	< 10 mΩ Δ max
5	Reseating	Manually unplug & plug the connector, 3 cycles		No evidence of physical damage	PASSED
6	Low Level Contact Resistance	EIA-364-23; apply a maximum voltage of 20 mV and a current of 100 mA.	Mated	< 10 mΩ Δ max from initial	< 10 mΩ Δ max

REVISION: D2	ECR/ECN INFORMATION: EC No: UCP2013-0422 DATE: 2012 / 07 / 31	TITLE: PRODUCT SPECIFICATION EXTERNAL iPass™ / iPass+™ I/O CONNECTOR & CABLE	SHEET No. 5 of 21
DOCUMENT NUMBER: PS-75586-001	CREATED / REVISED BY: TMCLELLAND	CHECKED BY: JLONG / JJANTELEZIO	APPROVED BY: MBANAKIS



PRODUCT SPECIFICATION

6.2 TEST GROUP 2

ITEM	TEST	TEST PROCEDURE	CONDITION	REQUIREMENT	ACTUAL
1	Low Level Contact Resistance	EIA-364-23; apply a maximum voltage of 20 mV and a current of 100 mA.	Mated	baseline	PASSED
2	Durability (precondition)	EIA-364-09; perform plug & unplug cycles: 50 times.		No evidence of physical damage	PASSED
3	Thermal Shock	EIA-364-32, Method A, test condition I, duration A4, ½ hr @each extreme	Mated	Conditioning Exposure	PASSED No physical data
4	Low Level Contact Resistance	EIA-364-23; apply a maximum voltage of 20 mV and a current of 100 mA.	Mated	< 10 mΩ Δ max from initial	< 10 mΩ Δ max
5	Cyclic Temperature & Humidity	EIA-364-31 Connectors should be cycled (24) times between 25° ± 3°C at 80% RH and 65 °± 3 °C at 50% RH). Ramp times should be 0.5 hour and dwell should be 1.0 hour.	Mated	Conditioning Exposure	PASSED No physical data
6	Low Level Contact Resistance	EIA-364-23; apply a maximum voltage of 20 mV and a current of 100 mA.	Mated	< 10 mΩ Δ max from initial	< 10 mΩ Δ max
7	Reseating	Manually unplug & plug the connector, 3 cycles		No evidence of physical damage	PASSED
8	Low Level Contact Resistance	EIA-364-23; apply a maximum voltage of 20 mV and a current of 100 mA.	Mated	< 10 mΩ Δ max from initial	< 10 mΩ Δ max

REVISION: D2	ECR/ECN INFORMATION: EC No: UCP2013-0422 DATE: 2012 / 07 / 31	TITLE: PRODUCT SPECIFICATION EXTERNAL iPasstm / iPass+tm I/O CONNECTOR & CABLE	SHEET No. 6 of 21
DOCUMENT NUMBER: PS-75586-001	CREATED / REVISED BY: TMCLELLAND	CHECKED BY: JLONG / JJANTELEZIO	APPROVED BY: MBANAKIS



PRODUCT SPECIFICATION

6.3 TEST GROUP 3

ITEM	TEST	TEST PROCEDURE	CONDITION	REQUIREMENT	ACTUAL
1	Low Level Contact Resistance	EIA-364-23; apply a maximum voltage of 20 mV and a current of 100 mA.	Mated	baseline	PASSED
2	Durability (precondition)	EIA-364-09; perform plug & unplug cycles: 50 times.		No evidence of physical damage	PASSED
3	Temperature Life (precondition)	EIA-364-17, method A, Test Condition 3 at 105°±2°C for 72 hours	Mated	Conditioning Exposur	
4	Low Level Contact Resistance	EIA-364-23; apply a maximum voltage of 20 mV and a current of 100 mA.	Mated	< 10 mΩ Δ max from initial	< 10 mΩ Δ max
5	Mechanical Vibration	EIA-364-28 test condition VII test condition letter D 15 minutes in each of 3 mutually perpendicular directions. Both mating halves rigidly fixed to not contribute to relative motion of one contact against another.	Mated	Discontinuity < 1 μsec No evidence of physical damage	PASSED
6	Mechanical Shock	EIA-364-27 test condition letter A 3 shocks in each axis (18) Both mating halves rigidly fixed to not contribute to relative motion of one contact against another.	Mated	Discontinuity < 1 μsec No evidence of physical damage	PASSED
7	Low Level Contact Resistance	EIA-364-23; apply a maximum voltage of 20 mV and a current of 100 mA.	Mated	< 10 mΩ Δ max from initial	< 10 mΩ Δ max

REVISION: D2	ECR/ECN INFORMATION: EC No: UCP2013-0422 DATE: 2012 / 07 / 31	TITLE: PRODUCT SPECIFICATION EXTERNAL iPasstm / iPass+tm I/O CONNECTOR & CABLE	SHEET No. 7 of 21
DOCUMENT NUMBER: PS-75586-001	CREATED / REVISED BY: TMCLELLAND	CHECKED BY: JLONG / JJANTELEZIO	APPROVED BY: MBANAKIS



PRODUCT SPECIFICATION

6.4 TEST GROUP 4

ITEM	TEST	TEST PROCEDURE	CONDITION	REQUIREMENT	ACTUAL
1	Low Level Contact Resistance	EIA-364-23; apply a maximum voltage of 20 mV and a current of 100 mA.	Mated	baseline	PASSED
2	Durability (precondition)	EIA-364-09; perform plug & unplug cycles: 50 times.		No evidence of physical damage	PASSED
3	Temperature Life (precondition)	EIA-364-17, method A, Test Condition 3 at 105±2°C for 72 hours	Mated	Conditioning Exposure	PASSED No physical data
4	Low Level Contact Resistance	EIA-364-23; apply a maximum voltage of 20 mV and a current of 100 mA.	Mated	<10 mΩ Δ max from initial	<10 mΩ Δ max
5	Mixed Flowing Gas	EIA-364-35 class IIA, Option 1A & 1B test condition VII for 14 days	See Note	Conditioning Exposure	PASSED
6	Low Level Contact Resistance	EIA-364-23; apply a maximum voltage of 20 mV and a current of 100 mA.	Mated	<10 mΩ Δ max from initial	<10 mΩ Δ max

Note:

1. Expose ½ of the specimens unmated for 2/3 of the test duration. Mate the specimen to the same one used during preconditioning temperature life. Expose for the duration of the test.
2. Characterize porosity & plating thickness before test sequence.

REVISION: D2	ECR/ECN INFORMATION: EC No: UCP2013-0422 DATE: 2012 / 07 / 31	TITLE: PRODUCT SPECIFICATION EXTERNAL iPass™ / iPass+™ I/O CONNECTOR & CABLE	SHEET No. 8 of 21
DOCUMENT NUMBER: PS-75586-001	CREATED / REVISED BY: TMCLELLAND	CHECKED BY: JLONG / JJANTELEZIO	APPROVED BY: MBANAKIS



PRODUCT SPECIFICATION

TEST GROUP 4 (CONTINUED)

ITEM	TEST	TEST PROCEDURE	CONDITION	REQUIREMENT	ACTUAL
7	Thermal Disturbance	Cycle connectors 10 times between 15° ± 3°C at 80% RH and 85 °± 3 °C at 50% RH. Ramps should be a minimum of 2°C per minute and dwell times should insure that the contacts reach the temperature extremes for a minimum of 5 minutes.	Mated	Conditioning Exposure	PASSED No physical data
8	Low Level Contact Resistance	EIA-364-23; apply a maximum voltage of 20 mV and a current of 100 mA .	Mated	<10 mΩ Δ max from initial	<10 mΩ Δ max
9	Reseating	Manually unplug & plug the connector, 3 cycles		No evidence of physical damage	PASSED
10	Low Level Contact Resistance	EIA-364-23; apply a maximum voltage of 20 mV and a current of 100 mA .	Mated	<10 mΩ Δ max from initial	<10 mΩ Δ max

REVISION:	ECR/ECN INFORMATION:	TITLE:	SHEET No.
D2	EC No: UCP2013-0422 DATE: 2012 / 07 / 31	PRODUCT SPECIFICATION EXTERNAL iPasstm / iPass+tm I/O CONNECTOR & CABLE	9 of 21
DOCUMENT NUMBER:	CREATED / REVISED BY:	CHECKED BY:	APPROVED BY:
PS-75586-001	TMCLELLAND	JLONG / JJANTELEZIO	MBANAKIS



PRODUCT SPECIFICATION

6.5 TEST GROUP 7

ITEM	TEST	TEST PROCEDURE	CONDITION	REQUIREMENT	ACTUAL
1	Dielectric Withstanding Voltage	EIA-364-20; apply a voltage of 300 VDC for 1 minute between adjacent terminals and between adjacent terminals and ground.	Mated	No disruptive discharge No leakage current in excess of 5mA	PASSED
2	Low Level Contact Resistance	EIA-364-23; apply a maximum voltage of 20 mV and a current of 100 mA.	Mated	baseline	PASSED
3	Durability	EIA-364-09; perform plug & unplug cycles: 250 times.		No evidence of physical damage	PASSED
4	Low Level Contact Resistance	EIA-364-23; apply a maximum voltage of 20 mV and a current of 100 mA.	Mated	<10 mΩ Δ max from initial	<10 mΩ Δ max
5	Dielectric Withstanding Voltage	EIA-364-20; apply a voltage of 300 VDC for 1 minute between adjacent terminals and between adjacent terminals and ground.	Mated	No disruptive discharge No leakage current in excess of 5mA	PASSED

Note:

1. Separate sets of test specimens will be used to access dielectric withstanding voltage and the change in low level contact resistance.
2. Dielectric withstanding voltage testing will use different contacts than those used for low level contact resistance testing.

REVISION: D2	ECR/ECN INFORMATION: EC No: UCP2013-0422 DATE: 2012 / 07 / 31	TITLE: PRODUCT SPECIFICATION EXTERNAL iPasstm / iPass+tm I/O CONNECTOR & CABLE	SHEET No. 10 of 21
DOCUMENT NUMBER: PS-75586-001	CREATED / REVISED BY: TMCLELLAND	CHECKED BY: JLONG / JJANTELEZIO	APPROVED BY: MBANAKIS



PRODUCT SPECIFICATION

6.6 MECHANICAL TEST GROUP 1

ITEM	TEST	TEST PROCEDURE	CONDITION	REQUIREMENT	ACTUAL
1	Temperature Rise (via current cycling)	Measure the temperature rise at the rated current after 96 hours. (45 minutes ON and 15 minutes OFF). Fixture as required.	Mated	Temperature Rise: +30°C maximum	0.3 A min. with < 30°C Temperature Rise

6.7 MECHANICAL TEST GROUP 2

ITEM	TEST	TEST PROCEDURE	CONDITION	REQUIREMENT	ACTUAL
1	Connector Mate Forces (Module only)	Mate connector at a rate of 25 mm per min.	Mate	2.5 N / contact pair MAX insertion force	0.5-0.75 N / force
2	Connector Un-mate Forces (Module only)	Un-mate connector at a rate of 25 mm per min.	Un-mate	0.5 N / contact pair MAX withdrawal force	0.25-0.35 N / contact pair
3	Plug Mate Forces	Mate connector at a rate of 25 mm per min.	Mate	2.5 N / contact pair plus 50 N MAX	26 ckt: 26 N – 40 N 38 ckt: 62 N – 82 N 68 ckt: 98 N – 134 N
4	De-Latch Plug (Axial Load)	Mate connector and place axial load on latch pull to de-latch plug	Un-mate	0.5 N / contact pair plus 20 N MAX	26 ckt: 16 N – 21.4 N 38 ckt: 18 N – 24 N 68 ckt: 40 N – 45 N
5	Latch Pull (Axial Load)	Place axial load on plug pull with 6.35 mm diameter pin	Mate	25 N MIN	PASSED (no physical damage)

REVISION: D2	ECR/ECN INFORMATION: EC No: UCP2013-0422 DATE: 2012 / 07 / 31	TITLE: PRODUCT SPECIFICATION EXTERNAL iPasstm / iPass+tm I/O CONNECTOR & CABLE	SHEET No. 11 of 21
DOCUMENT NUMBER: PS-75586-001	CREATED / REVISED BY: TMCLELLAND	CHECKED BY: JLONG / JJANTELEZIO	APPROVED BY: MBANAKIS



PRODUCT SPECIFICATION

6.8 MECHANICAL TEST GROUP 3

ITEM	TEST	TEST PROCEDURE	CONDITION	REQUIREMENT	ACTUAL
1	Terminal Retention Force	Axial pullout force on the terminal in the housing at a rate of 25 mm (1 in) per min.		4.5 N MINIMUM retention force	6.2 N MINIMUM
2	Normal Force	Apply a perpendicular force.		0.49 N, (50 grams) MINIMUM normal force	0.49 N, (50 grams) MINIMUM normal force
3	Solder Ring Retention to Housing Peg	Axial pullout force on the terminal in the housing at a rate of 25 mm (1 in) per min.		5.0 N MINIMUM retention force	6.6 N MINIMUM

6.9 MECHANICAL TEST GROUP 4

ITEM	TEST	TEST PROCEDURE	CONDITION	REQUIREMENT	ACTUAL
1	Latitudinal Load	Mate connector and load plug with latitudinal load until open circuit. See section 9.	Mated	75 N MIN	90 N (no open circuit)
2	Longitudinal Load	Mate connector and load plug with longitudinal load until open circuit. See section 9.	Mated	75 N MIN	90 N (no open circuit)
3	Cable Pullout Force (Axial Load)	Mate plug to connector and apply an axial pullout force on the wire at a rate of 25 mm per min.	Mated	26 ckt – 88 N MIN 38 ckt – 100 N MIN	26 ckt: 91 N – 97 N
4	Cable Pullout Force (Right Angle Load)	Mate plug to connector and apply an right angle pullout force on the wire at a rate of 25 mm per min.	Mated	75 N MIN	125 N – 145 N

REVISION: D2	ECR/ECN INFORMATION: EC No: UCP2013-0422 DATE: 2012 / 07 / 31	TITLE: PRODUCT SPECIFICATION EXTERNAL iPasstm / iPass+tm I/O CONNECTOR & CABLE	SHEET No. 12 of 21
DOCUMENT NUMBER: PS-75586-001	CREATED / REVISED BY: TMCLELLAND	CHECKED BY: JLONG / JJANTELEZIO	APPROVED BY: MBANAKIS



PRODUCT SPECIFICATION

6.10 MECHANICAL TEST GROUP 5

ITEM	TEST	TEST PROCEDURE	CONDITION	REQUIREMENT	ACTUAL
1	Low Level Contact Resistance	EIA-364-23; apply a maximum voltage of 20 mV and a current of 100 mA.	Mated	baseline	PASSED
2	Wire Flex	Flex cable 180° for 20 cycles. Test per EIA 364-41 test cond. I: 24 AWG – with X = 40 mm 26 AWG – with X = 30 mm 28 AWG – with X = 30 mm	Mated	10 mΩ MAX (change from initial) No physical damage	20 cycles, no physical damage
3	Low Level Contact Resistance	EIA-364-23; apply a maximum voltage of 20 mV and a current of 100 mA.	Mated	< 10 mΩ Δ max from initial	< 10 mΩ Δ max

6.11 MECHANICAL TEST GROUP 6

ITEM	TEST	TEST PROCEDURE	CONDITION	REQUIREMENT	ACTUAL
1	Solderability	Per SMES-152		Solder Coverage 95% minimum	PASSED
2	SMT Process Compatibility (Pb Free)	See Section 10.0 for Molex Connector Only Test Profile		Dimensional: Conformance to Sales Drawing Requirements Visual: No Damage	No opens No bridges No damage

REVISION: D2	ECR/ECN INFORMATION: EC No: UCP2013-0422 DATE: 2012 / 07 / 31	TITLE: PRODUCT SPECIFICATION EXTERNAL iPasstm / iPass+tm I/O CONNECTOR & CABLE	SHEET No. 13 of 21
DOCUMENT NUMBER: PS-75586-001	CREATED / REVISED BY: TMCLELLAND	CHECKED BY: JLONG / JJANTELEZIO	APPROVED BY: MBANAKIS



PRODUCT SPECIFICATION

6.12 MECHANICAL TEST GROUP 7

ITEM	TEST	TEST PROCEDURE	CONDITION	REQUIREMENT	ACTUAL
1	Longitudinal Load (connector only)	Mate connector and load module in peel and shear modes.		68 Ckt Peel: 15 N min Shear: 150 N min 26 Ckt Peel: 7 N min Shear: 35 N min	68 Ckt Peel: 20 N min Shear: 180 N min 26 Ckt Peel: 13 N min Shear: 45 N min
2	Longitudinal Load (connector only) (with solder ring)	Mate connector and load module in peel and shear modes.		26 Ckt Peel: 15 N min Shear: 95 N min	26 Ckt Peel: 23 N min Shear: 110 N min

6.13 MECHANICAL TEST GROUP 8

ITEM	TEST	TEST PROCEDURE	CONDITION	REQUIREMENT	ACTUAL
1	Compliant Pin Insertion into PCB	Apply an axial insertion force on the terminal at a rate of 25±6 mm/min.		35 N (7.9 lbf) max insertion force per pin	xx N max
2	Compliant Pin Retention to PCB	Apply an axial extraction force on the terminal at a rate of 25±6 mm/min.		9 N (2 lbf) max retention force per pin	xx N min

REVISION: D2	ECR/ECN INFORMATION: EC No: UCP2013-0422 DATE: 2012 / 07 / 31	TITLE: PRODUCT SPECIFICATION EXTERNAL iPasstm / iPass+tm I/O CONNECTOR & CABLE	SHEET No. 14 of 21
DOCUMENT NUMBER: PS-75586-001	CREATED / REVISED BY: TMCLELLAND	CHECKED BY: JLONG / JJANTELEZIO	APPROVED BY: MBANAKIS



PRODUCT SPECIFICATION

7.0 PERFORMANCE (HIGH SPEED CHARACTERIZATION)

7.1 SIGNAL INTEGRITY REQUIREMENTS (CONNECTOR ONLY)

ITEM	DESCRIPTION	TEST CONDITION	REQUIREMENT	ACTUAL
1	Return Loss	Frequency range 50MHz to 7.5GHz Frequency range 7.5GHz to 15GHz • 2.5dB at 15GHz	≤ -10 dB Equation 1	-16 dB
2	Differential Impedance	Rise-time of 25ps (20-80%)	100 ± 10 ohms	92-109 ohms SMT vs Compliant
3	Insertion Loss	Frequency range 50 MHz to 12.5 GHz	Equation 2	-0.90 dB
4	Crosstalk	NEXT, FEXT for adjacent pairs within a row NEXT, FEXT for adjacent pairs across rows *Measured at 25ps 20-80% rise-time	≤ 2 % ≤ 2 %	≤ 0.5 % ≤ 0.5 %
5	Isolation	Frequency range 50MHz to 15GHz Measure near-end and far-end isolation - Adjacent pairs within a row - Adjacent pairs across rows	-30 dB	N/A
6	Differential Skew (Within Pair)	Mate plug to receptacle	<1 ps	<1 ps

Note:

PCB Interface Option 1 – SMT
 PCB Interface Option 2 – Compliant Pin, single port
 PCB Interface Option 3 – Compliant Pin, dual port or stacked ports
 Equation 1: $\leq -10 - 25 \log_{10}(f / 7.5\text{GHz})$ dB
 Equation 2: $\leq -20 \log_{10}(a1 * \sqrt{f} + a2 * f + a3 * f^2)$ dB
 Where a1=1.0E-0.5, a2=1.0E-10, a3=1.0E-20

REVISION: D2	ECR/ECN INFORMATION: EC No: UCP2013-0422 DATE: 2012 / 07 / 31	TITLE: PRODUCT SPECIFICATION EXTERNAL iPasstm / iPass+tm I/O CONNECTOR & CABLE	SHEET No. 15 of 21
DOCUMENT NUMBER: PS-75586-001	CREATED / REVISED BY: TMCLELLAND	CHECKED BY: JLONG / JJANTELEZIO	APPROVED BY: MBANAKIS



PRODUCT SPECIFICATION

7.2 SIGNAL INTEGRITY REQUIREMENTS (CONNECTOR & CABLE SYSTEM, SAS/SATA)

ITEM	DESCRIPTION	TEST CONDITION	REQUIREMENT	ACTUAL
1	Differential Impedance	Rise time of 55 ps (20 % - 80 %)	100 ± 15 ohms (mated cable)	91-101 ohms
2	Common-mode Impedance	Rise time of 55 ps (20 % - 80 %)	32.5 ± 7.5 ohms (cable)	26-37 ohms
3	Differential Mode Return Loss	- Measured from 10 MHz < f < 4.5 GHz - Measured from 4.5 GHz < f < 6.5 GHz	≤ -8 dB ≤ -8+16 dB per decade	≤ -xx dB ≤ -xx dB
4	Common Mode Return Loss	Measured from 10 MHz to 6.5 GHz	≤ -8 dB	≤ -xx dB
5	Differential to Common Mode Conversion	- SCD22: 10 MHz < f < 9.0 GHz - SCD22: 10 MHz < f < 9.0 GHz	≤ -26 dB ≤ -20 dB	≤ -xx dB ≤ -xx dB
6	Differential Insertion Loss	Measured from 10 MHz to 3.0 GHz	≤ -1.25-(f/250) dB	≤ -xx dB (10 m, 24 AWG)
7	Multi-Lane Isolation	- Measured from 10 MHz to 4.5 GHz - (4) near-end aggressor pairs and (1) victim pair - TotalNEXT(f) = 10 × log ∑ ₁ ⁴ 10 ^{(NEXT(f)/10)}	≤ -26 dB	≤ -40 dB @ 4.5 GHz (10 m, 24 AWG)

REVISION: D2	ECR/ECN INFORMATION: EC No: UCP2013-0422 DATE: 2012 / 07 / 31	TITLE: PRODUCT SPECIFICATION EXTERNAL iPasstm / iPass+tm I/O CONNECTOR & CABLE	SHEET No. 16 of 21
DOCUMENT NUMBER: PS-75586-001	CREATED / REVISED BY: TMCLELLAND	CHECKED BY: JLONG / JJANTELEZIO	APPROVED BY: MBANAKIS



PRODUCT SPECIFICATION

7.3 SIGNAL INTEGRITY REQUIREMENTS (CONNECTOR & CABLE SYSTEM, PCIE)

ITEM	DESCRIPTION	TEST CONDITION	REQUIREMENT	ACTUAL
1	Differential Mode Return Loss	- Measured from 10 MHz f 1.25 GHz - Measured from 1.25 GHz f 2.5 GHz	≤ -12 dB $\leq -12+16$ dB per decade	$\leq -xx$ dB $\leq -xx$ dB
2	Differential Insertion Loss	Measured from 10 MHz to 3.0 GHz	≤ -5 dB @ 625 MHz ≤ -7.5 dB @ 1.25 GHz	$\leq -xx$ dB $\leq -xx$ dB
3	Inter-pair skew	Rise time of 70 ps (20 % - 80 %)	≤ 1.3 ns	$\leq xx$ ps
4	Intra-pair skew	Rise time of 70 ps (20 % - 80 %)	≤ 40 ps	$\leq xx$ ps
5	Multi-Lane Isolation	- Measured from 10 MHz to 2.5 GHz - (4) near-end aggressor pairs and (1) victim pair - TotalNEXT(f) = $10 \times \log \sum_{1}^{4} 10^{(\text{NEXT}(f)/10)}$	≤ -31.5 dB	≤ -40 dB @ 4.5 GHz (10 m, 24 AWG)

7.4 SIGNAL INTEGRITY REQUIREMENTS (CONNECTOR & CABLE SYSTEM, 12X)

ITEM	DESCRIPTION	TEST CONDITION	REQUIREMENT	ACTUAL
1	Differential Mode Return Loss	- Measured from 10 MHz f 2.5 GHz	≤ -10 dB	$\leq -xx$ dB
2	Differential Insertion Loss	Measured from 10 MHz to 5.0 GHz	≤ -8 dB @ 100 MHz ≤ -8 dB @ 200 MHz ≤ -8.5 dB @ 625 MHz ≤ -12.1 dB @ 1.25 GHz ≤ -14.7 dB @ 1.875 GHz ≤ -17 dB @ 2.5 GHz	$\leq -xx$ dB @ 100 MHz $\leq -xx$ dB @ 200 MHz $\leq -xx$ dB @ 625 MHz $\leq -xx$ dB @ 1.25 GHz $\leq -xx$ dB @ 1.875 GHz $\leq -xx$ dB @ 2.5 GHz

REVISION: D2	ECR/ECN INFORMATION: EC No: UCP2013-0422 DATE: 2012 / 07 / 31	TITLE: PRODUCT SPECIFICATION EXTERNAL iPasstm / iPass+tm I/O CONNECTOR & CABLE	SHEET No. 17 of 21
DOCUMENT NUMBER: PS-75586-001	CREATED / REVISED BY: TMCLELLAND	CHECKED BY: JLONG / JJANTELEZIO	APPROVED BY: MBANAKIS



PRODUCT SPECIFICATION

8.0 PACKAGING

8.1 CONNECTOR AND SHELL

- 8.1.1 Product shall be packaged in tape and reel per the packaging specification as called out on the applicable assembly print.
- 8.1.2 Packaging shall meet the requirements of and be tested per the packaging specification as called out on the applicable assembly print.

8.2 PLUG AND CABLE ASSEMBLY

- 8.2.1 Product shall be packaged to protect against damage during handling, transit and storage.

REVISION: D2	ECR/ECN INFORMATION: EC No: UCP2013-0422 DATE: 2012 / 07 / 31	TITLE: PRODUCT SPECIFICATION EXTERNAL iPasstm / iPass+tm I/O CONNECTOR & CABLE	SHEET No. 18 of 21
DOCUMENT NUMBER: PS-75586-001	CREATED / REVISED BY: TMCLELLAND	CHECKED BY: JLONG / JJANTELEZIO	APPROVED BY: MBANAKIS



PRODUCT SPECIFICATION

9.0 GAGES AND FIXTURES

Test setup for latitudinal and longitudinal load testing and shell retention testing. Probe is about 6mm in diameter with a full radius nose. The probe is to be placed 20mm from the front edge of the receptacle and located at the centerline of the plug. Apply load to plug at a rate of 25mm per minute.

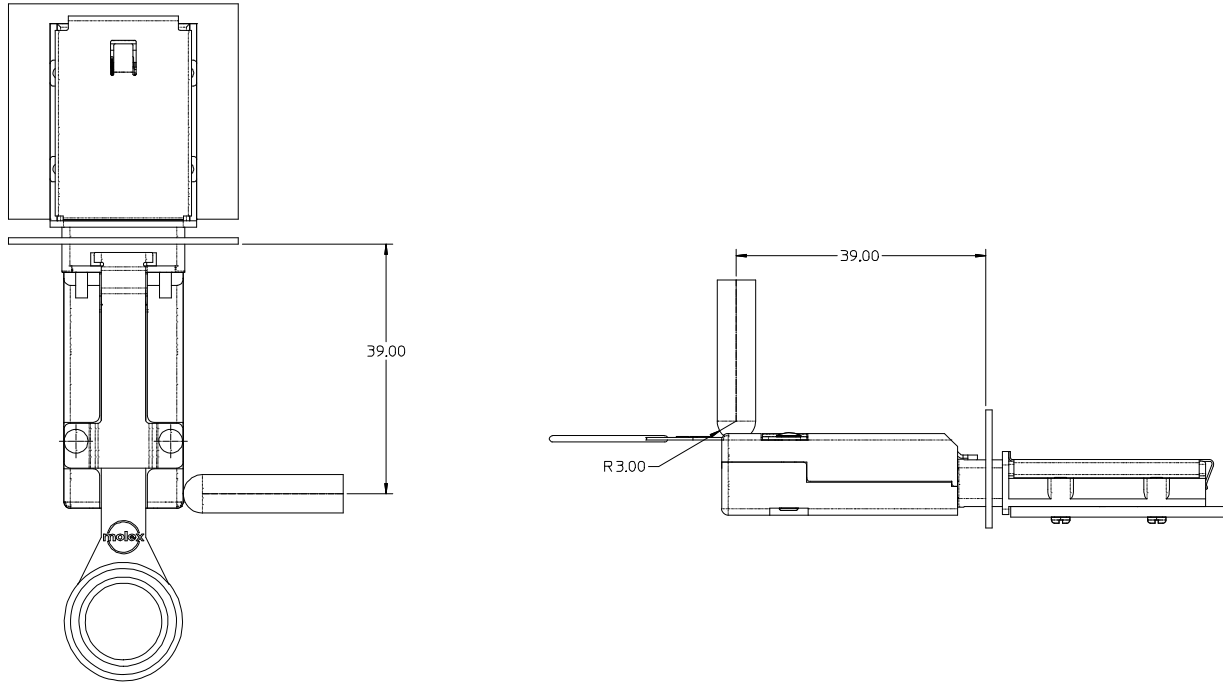

Test setup for peel and shear testing. Apply load to plug at a rate of 25mm per minute.

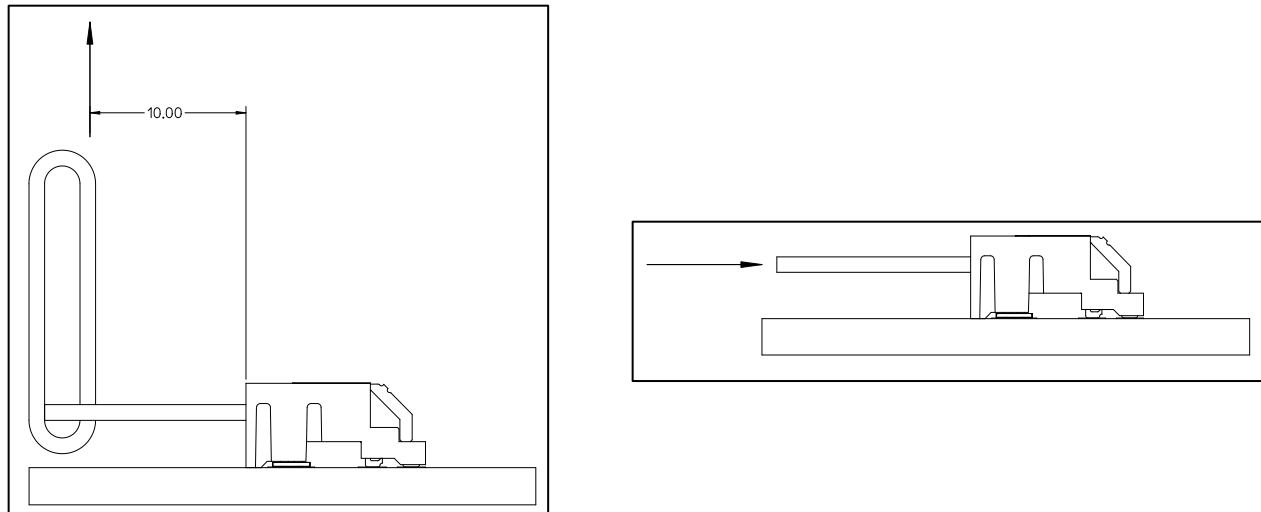

REVISION: D2	ECR/ECN INFORMATION: EC No: UCP2013-0422 DATE: 2012 / 07 / 31	TITLE: PRODUCT SPECIFICATION EXTERNAL iPass™ / iPass+™ I/O CONNECTOR & CABLE	SHEET No. 19 of 21
DOCUMENT NUMBER: PS-75586-001	CREATED / REVISED BY: TMCLELLAND	CHECKED BY: JLONG / JJANTELEZIO	APPROVED BY: MBANAKIS



PRODUCT SPECIFICATION

10.0 OTHER INFORMATION

10.1 MOLEX CONNECTOR ONLY TEST PROFILE

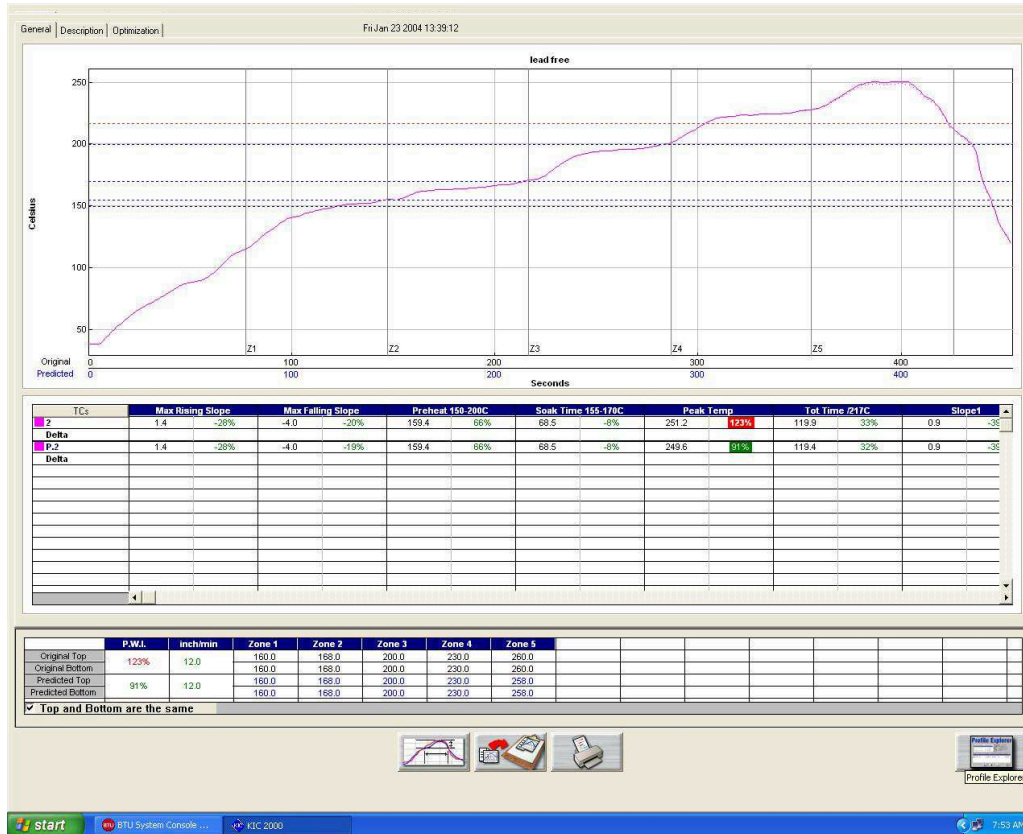

SMT Profile

Ramp-Up:	Average Rate of 3° C/second max
Preheat Temperature:	150° C min. to 200° C max. for 60-180 seconds
Time maintained above:	217° C for 60-90 seconds
Peak Temperature:	260° C
Time within 5° C of actual Peak Temperature:	10-20 seconds
Ramp-Down:	Average Rate of 6° C/second max
Cycle Duration, 25° C to Peak Temperature:	8 minutes maximum

10.2 INVERTED SMT APPLICATION

See AS-75586-001 Application Specification for inverted SMT application. Glue must be used on the locating pegs to hold the part while inverted through the reflow process

REVISION: D2	ECR/ECN INFORMATION: EC No: UCP2013-0422 DATE: 2012 / 07 / 31	TITLE: PRODUCT SPECIFICATION EXTERNAL iPass™ / iPass+™ I/O CONNECTOR & CABLE	SHEET No. 20 of 21
DOCUMENT NUMBER: PS-75586-001	CREATED / REVISED BY: TMCLELLAND	CHECKED BY: JLONG / JJANTELEZIO	APPROVED BY: MBANAKIS



PRODUCT SPECIFICATION

10.3 PCB REQUIREMENTS

These requirements are for connector series 75581, 76024, 76105 & 75758 only.

The compliant pin shall be capable of being inserted one time.

The PCB hole shall be capable of retaining the compliant pin for a maximum of three insertions. The removal of the compliant pin from the PCB shall not damage the PCB hole beyond the point to be able to retain a compliant pin (that has not been inserted into a PCB).

The minimum thickness of the PCB for use with the compliant pin is 1.35 mm.

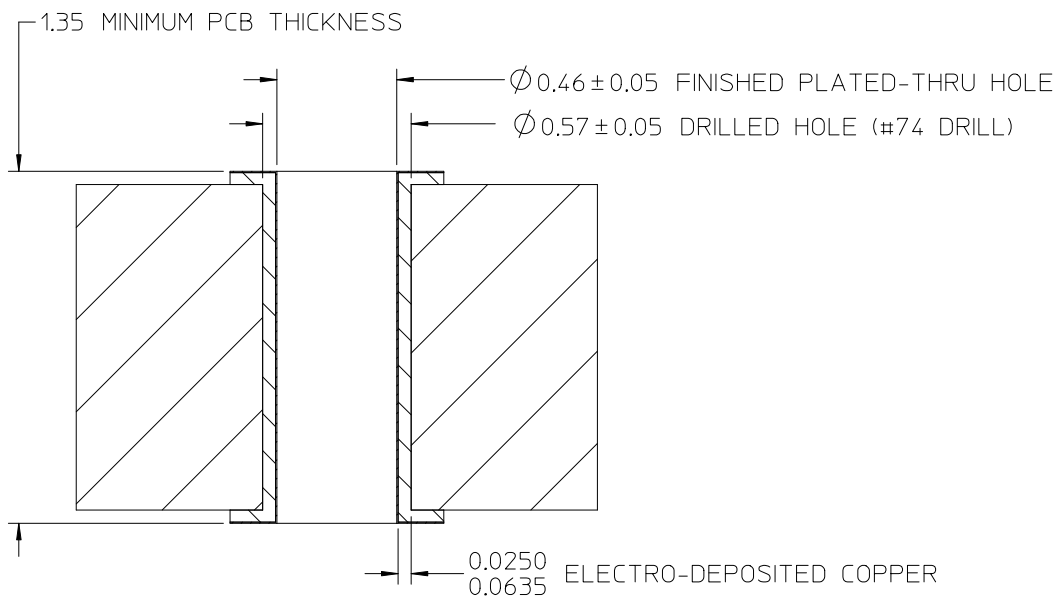

PLATING DETAIL FOR
0.46MM DIA.
COMPLIANT PIN HOLE

REVISION: D2	EGR/ECN INFORMATION: EC No: UCP2013-0422 DATE: 2012 / 07 / 31	TITLE: PRODUCT SPECIFICATION EXTERNAL iPasstm / iPass+tm I/O CONNECTOR & CABLE	SHEET No. 21 of 21
DOCUMENT NUMBER: PS-75586-001	CREATED / REVISED BY: TMCCLELLAND	CHECKED BY: JLONG / JJANTELEZIO	APPROVED BY: MBANAKIS